

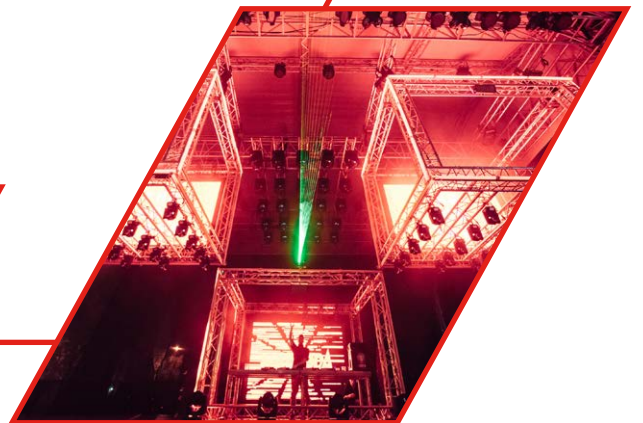

Truss Aluminium Factory

CATALOGUE

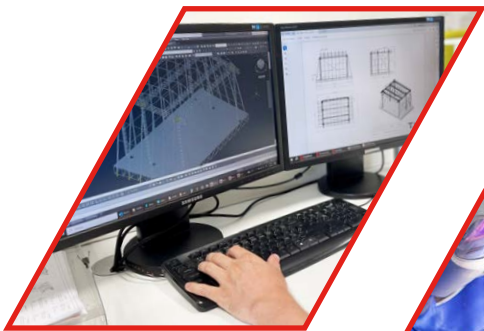



The FACTORY



TAF CZ

Truss Aluminium Factory (TAF) was founded in 1998 as a manufacturer of high-quality aluminium truss & support structures. Over the years, its staff has grown from 5 employees to more than 150 worldwide, which includes 75 highly experienced welders.

All TAF products are manufactured in TAF's state-of-the-art factory, which features a fully automated robotic arm that performs highly precise welds and helps to increase production output. All TAF products are subjected to strict quality control processes during the production process and carefully tested before leaving the factory.

TAF products are distributed across the EMEA region by TAF's global headquarters in Olomouc, Czech Republic. Its two factory distribution offices – TAF UK and TAF USA - serve customers across the UK and Ireland, North/Central/South America, and the Caribbean.

TAF aluminium truss and support structures feature three connection systems - Quicklock (conical, spigoted), bolted, and fork – for satisfying each customer's preferences and ensuring wide compatibility with other truss brands. The extensive TAF product portfolio also includes towers, roofs, LED frames, stage decks, ramps, barriers, exhibit designs, and truss accessories.





TAF's highly experienced and knowledgeable in-house design & engineering department provides high-level services for custom and bespoke projects, together with the design and production of custom truss.

The many applications of TAF truss include support structures for amusement facilities, family centers, virtual reality spaces, sport/obstacle courses, trade show booths, corporate events, retail displays, sporting events, church lighting, flying rigs, shopping centers, DJ booths, indoor/outdoor concerts, live events, and more.



TAF products are trusted by event and production rental companies around the world for providing safe, strong, and sturdy support for their largest and most technically complex concerts and events.

From the smallest support structures to massive events, TAF has you covered. Safely and securely!

Mission Statement

We strive each day to earn the trust of our customers, and ensure their peace of mind, by helping them meet their deadlines with consistent, timely delivery of safe, high-quality TAF products.

Promise

We provide reliable, on-time delivery of our precisely manufactured, high-quality products that fully satisfy your needs and ensure the safety of your structures.



COMPANY OFFICES

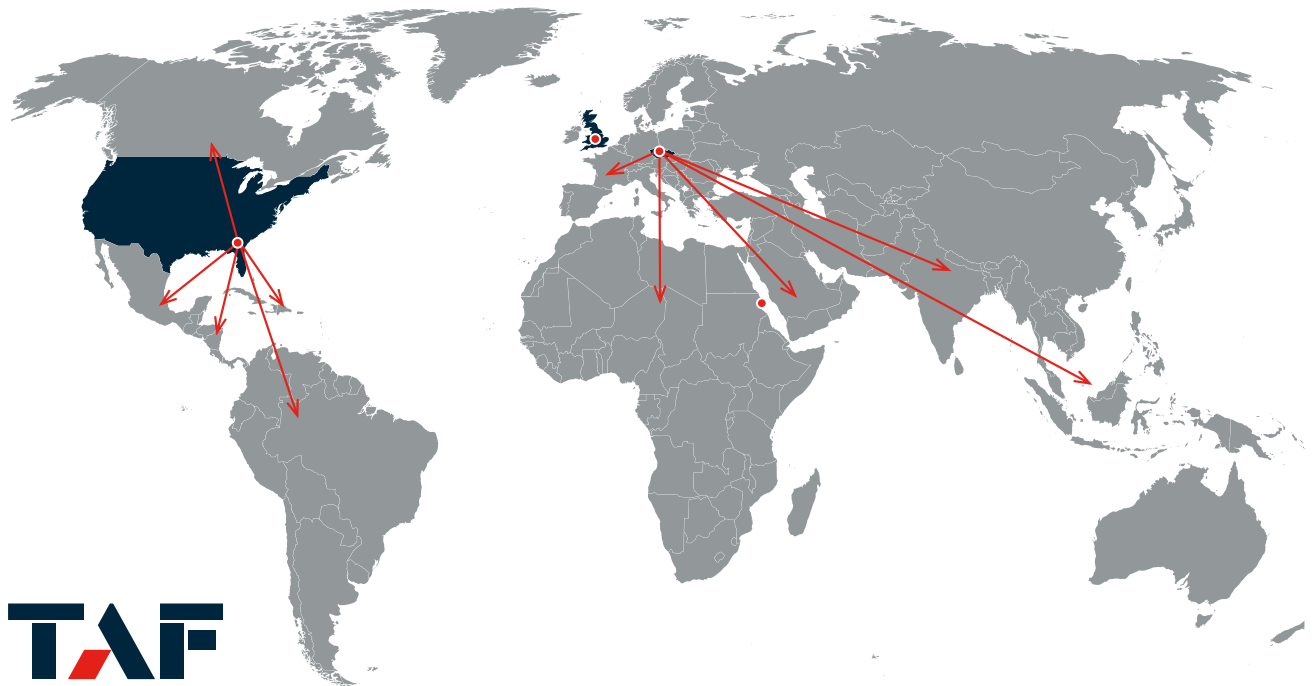

SERVING CUSTOMERS WORLDWIDE

TAF provides its extensive range of truss, support structures, and related products quickly and efficiently to customers across the globe via its three offices in the Czech Republic, the UK, and the USA. The optimized location of each office allows them to faithfully deliver on TAF's promise of "Truss on Time".

TAF UK

TAF UK serves customers in the UK and Ireland, with offices and warehouse located in Walsall, West Midlands in the UK.

Services:

- Stock in the UK
- Same Day/Next Day delivery of selected products
- Complete turn-key service
- Design and engineering
- Custom fabrication, design & installation
- Static calculations on request
- Powder coating in any color on request

TAF USA

TAF USA serves customers across North/Central/South America and the Caribbean. Their offices and 20,000 square foot warehouse are located in New Smyrna Beach, Florida.

Services:

- Stock in the USA
- Design and engineering
- Static calculations on request
- Powder coating in any color on request
- Same Day/Next Day delivery of selected products
- Complete turn-key service



February 2024 saw the opening of the **TAF UK** office and warehouse located in Walsall, West Midlands. The value TAF UK provides to its customers has been cemented with the TrussLite UK workforce, which has 25 years of experience on the market and the largest truss hire stockists in the UK. For more than a decade, TrussLite-certified products were manufactured by TAF's modern, high-capacity factory to support with the delivery and construction/installation of a wide range of structures across many different industries in the UK and Ireland.

The extensive knowledge, reputation and the leading experience of TAF UK ensures that its customers receive a complete end-to-end solution for events, exhibitions, staging, bespoke projects and more, utilising high-level TAF products and services. Custom solutions provided by TAF UK offer a more sustainable and effective alternative to regular structures across multiple sectors, for both indoor and outdoor projects.

In keeping with TAF's "Truss on Time" promise, TAF UK shall consistently maintain stock of TAF products directly in the UK to fulfil orders and demands of their customers quickly and efficiently, coupled with same day or next day delivery options on selected products from the range.



TAF USA was established in 2009 in New Smyrna Beach, Florida. After more than 15 years on the American market, it has earned its reputation as a leading distributor of aluminium truss and accessories.

All TAF products are stocked in its 20,000 square foot warehouse in New Smyrna Beach, expediting delivery to its customers across North, Central, and South America and the Caribbean.

TAF USA offers custom design and engineering services, along with the provision of static calculation for the wide range of projects required of its customers.





- Use of semi-automatic pipe cutting machines for main tubes of our trussing segments and fully automatic pipe cutting machines for the braces gives us an advantage in the precision and speed of production.



- The TAF factory features high-quality tooling for welding processes.



- All TAF products are carefully inspected for manufacturing defects, packed in 5-layer boxes, labelled, and loaded in trucks for transport. Our triple quality control system greatly reduces the chance of defective pieces being dispatched from the factory.

CERTIFICATES



- Static Calculations are required documentation for all trussing lines manufactured by TAF and are used by TÜV NORD and TÜV SÜD for testing TAF trussing segments. Static calculations are required for custom truss structures to ensure proper assembly and usage.

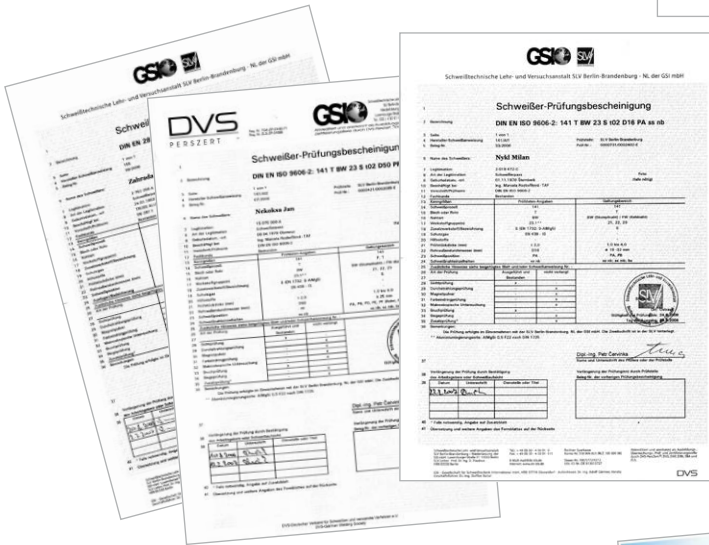
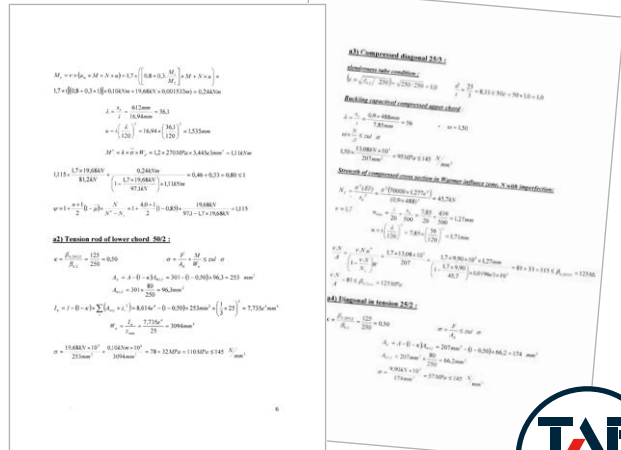

- Our welders are trained and certified by GSI SLV in accordance with the highest quality standards for welding aluminium alloys.

- TAF products are manufactured in accordance with the harmonized European EN 1090 standard, which is the latest standard for manufacturing steel and aluminium trusses. You can therefore count on TAF production processes following the highest European standards.



- TÜV certification of TAF trussing lines ensures they are of the highest quality and can safely support weights listed in their official loading tables.

QUICKLOCK LINE	11
FT14 box	12
FT21 single	14
FT22 double	16
FT23 triangle	20
FT24 box	26
Accessories FT21–24	30
FT31 single	32
FT32 / HT32 double	34
FT33 / HT33 triangle	40
FT34 / HT34 box	46
FT42 / HT42 double	50
FT43 / HT43 triangle	54
FT44 / HT44 box	60
FTR4030 rectangle	64
TT34 box	65
TT44 box	66
TC35 box	68
TC45 box	70
Accessories FT31-TC45	74
PT31 single	80
PT32 double	82
PT33 / PTH33 triangle	86
PT34 / PTH34 box	92
PT44 / PTH44 box	96
TS36R rectangle	100
TT54M box	102
TT74M rectangle	103
TT104M rectangle	104
Accessories FT31-TT74M	106

BOLTED TRUSS	109
FTB-L	110
FTB-M	112
FTBH	113

FORK TRUSS	115
GS350	116
GS500N	117
GS620	118
GS910	119
PR1 Pre-Rig Truss	120
PR2 Pre-Rig Truss	123

QUICKLOCK LINE	
U-Frames	126
Vario Plate	129

CLAMPS	130
---------------	------------

TOWERS	137
Tower 05	138
Tower 1	140
Tower 2	142
Bolted Tower TFTB-L	146
PA Tower 05	148
PA Tower 1	150
PA Vertical Tower 1	152
Tower Lifters	154

LED FRAMES	157
LED Support	158
LED frame 1	160
LED frame 2	162
LED frame 3	164
LED frame 4	166

ROOFS	169
Roof RST	170
Roof RSTS	172
Roof 1	174
Roof GB 8 x 6 m	176
Roof 2	178
Roof ARC 12 x 12 x 6 m	180
Roof KD 14 x 10 x 9 m	182
Roof 3	184
Roof 4	186

STAGES	188
---------------	------------

BARRIERS	190
-----------------	------------

TRUCK RAMPS	192
--------------------	------------

SPECS SUMMARY	194
----------------------	------------

QUICKLOCK LINE

Our Quicklock line is defined by its quick-lock connection system. The main advantage of this connection is fast and easy assembly of trusses, while maintaining a high level of strength and durability. This trussing system, also known as conical or spigoted truss, represents the widest range of TAF aluminium trussing products. All lines of this truss come with a connection kit as standard.

We offer several types of Quicklock trussing segments.

Once you choose the type that suits your needs, you will be presented with all available trussing lines that come with this connection. These lines differ in their dimensions, as well as in the type of main tube and braces.

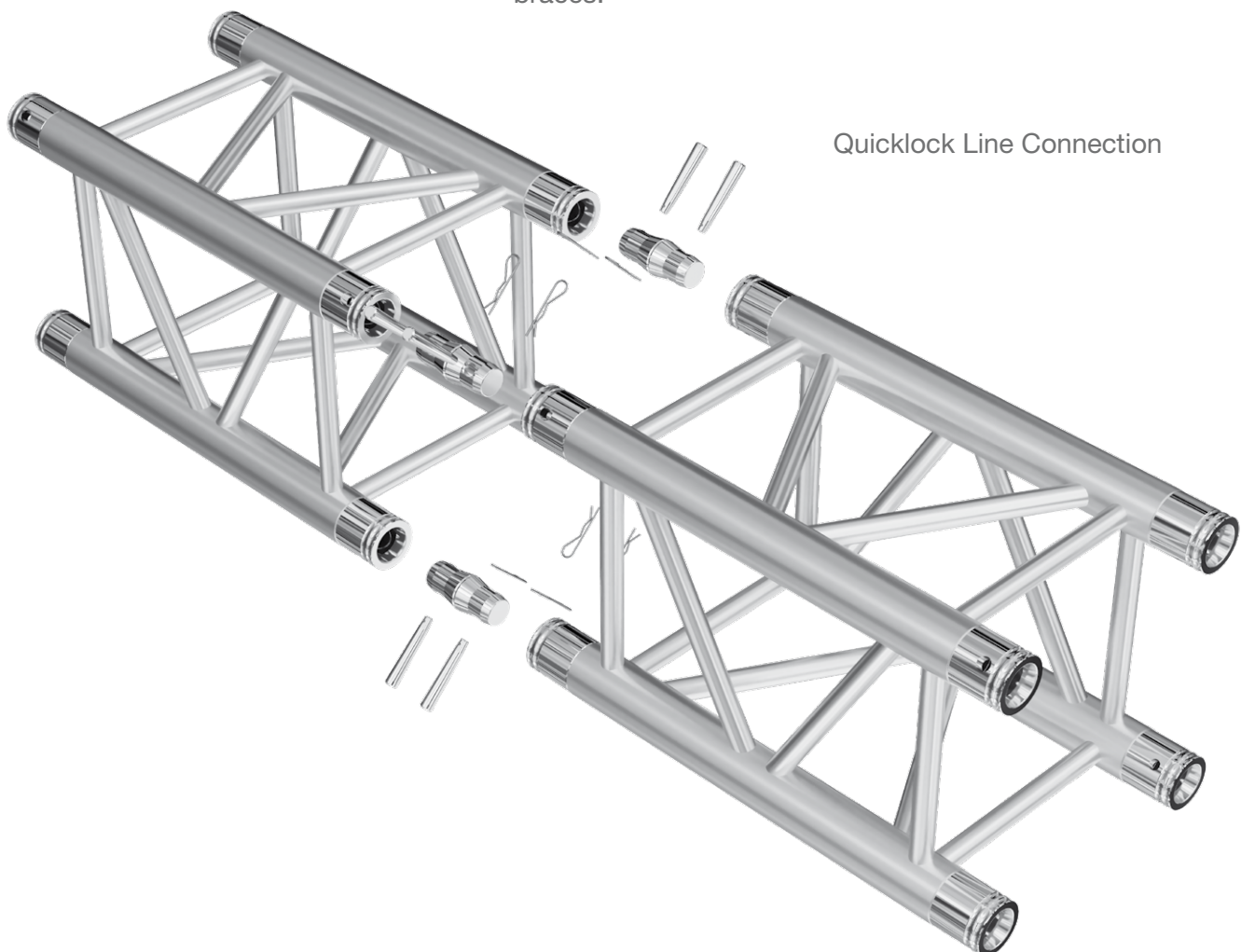

Quicklock Line Connection

SPECIFICATIONS

Tubes	20 x 2 mm (0.79 x 0.08 in)
Braces	6 mm (0.24 in)
Alloy	EN AW-6082 T6

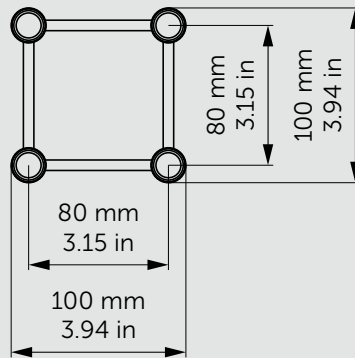

LOADING TABLES

		2 m	4 m	6 m	8 m	10 m
UDL [kg/m]		220	61	29	14	9
Deflection [mm]		12.1	41.5	91.7	155.7	261.1
CPL [kg]		147	93	69	52	44
Deflection [mm]		6.4	25.4	60.5	118.5	196.5
		6.56 ft	13.12 ft	19.68 ft	26.24 ft	32.81 ft
UDL [lbs/ft]		147.9	41	19.5	9.4	6
Deflection [in]		0.5	1.6	3.6	6.1	10.3
CPL [lbs]		324.1	205.1	152.1	114.7	97
Deflection [in]		0.3	1	2.4	4.7	7.7

Loading tables are valid for static loads and spans with two supporting points.

Spans must be supported at each end.

Contact structural engineer if there are more supporting points applied or dynamic and wind loads involved.

STRAIGHT SEGMENT LENGTHS

Code	Length		Weight	
FT14-50	0.5 m	1.64 ft	0.9 kg	2.02 lbs
FT14-100	1 m	3.28 ft	1.7 kg	3.83 lbs
FT14-150	1.5 m	4.92 ft	2.6 kg	5.64 lbs
FT14-200	2 m	6.56 ft	3.4 kg	7.52 lbs
FT14-250	2.5 m	8.20 ft	4.2 kg	9.33 lbs
FT14-300	3 m	9.84 ft	5.1 kg	11.14 lbs

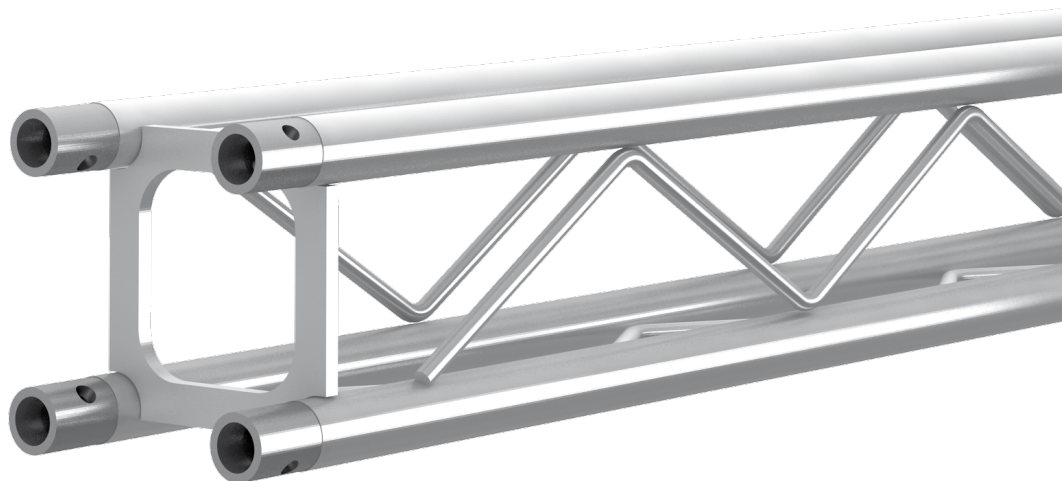



1004

Base plate for FT14



1150

Pin for FT14



1152

Safety clip for FT14



1101

Connector for FT14

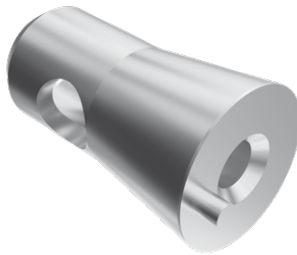

1116

Steel male halfconnector for FT14 with M4 thread



1124

Connection set for FT14

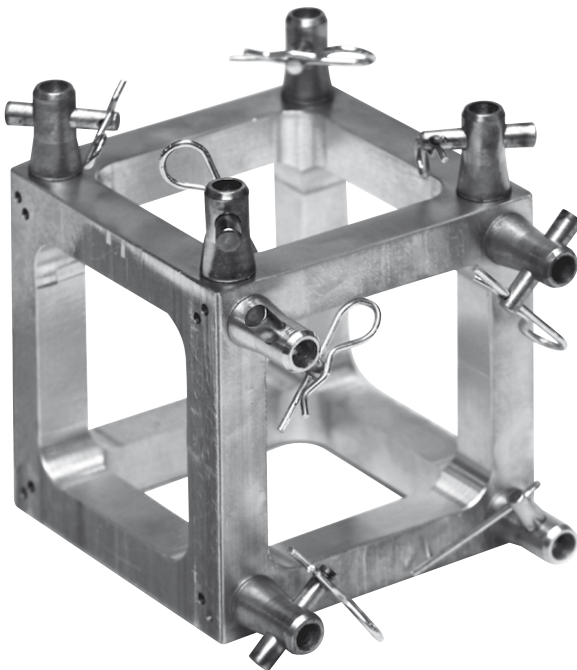

FT14-MCB



Multi connection box
0.1 x 0.1 m (0.33 x 0.33 ft)
0.8 kg (1.70 lbs)

Includes connection sets for two ways.

SPECIFICATIONS

Tubes	35 x 2 mm (1.38 x 0.08 in)
Alloy	EN AW-6060 T66

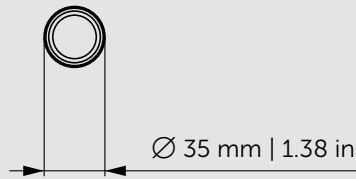

LOADING TABLES

		1 m	2 m	3 m	4 m
UDL [kg/m]		113	28	13	7
Deflection [mm]		7.4	29.7	66.7	118.6
CPL [kg]		56	28	19	14
Deflection [mm]		5.9	23.7	53.4	94.9
		3.28 ft	6.56 ft	9.84 ft	13.12 ft
UDL [lbs/ft]		75.9	18.8	8.7	4.7
Deflection [in]		0.3	1.2	2.6	4.7
CPL [lbs]		123.5	61.7	41.9	30.9
Deflection [in]		0.2	0.9	2.1	3.7

Loading tables are valid for static loads and spans with two supporting points. Spans must be supported at each end.

Contact structural engineer if there are more supporting points applied or dynamic and wind loads involved.

STRAIGHT SEGMENT LENGTHS

Code	Length		Weight	
FT21-50	0.5 m	1.64 ft	0.3 kg	0.74 lbs
FT21-100	1 m	3.28 ft	0.6 kg	1.36 lbs
FT21-150	1.5 m	4.92 ft	0.9 kg	1.98 lbs
FT21-200	2 m	6.56 ft	1.2 kg	2.59 lbs
FT21-250	2.5 m	8.20 ft	1.5 kg	3.22 lbs
FT21-300	3 m	9.84 ft	1.7 kg	3.82 lbs

The FT21 single tubes are used only for decorations and design purposes.

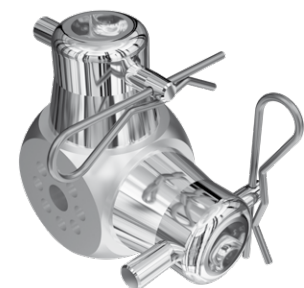
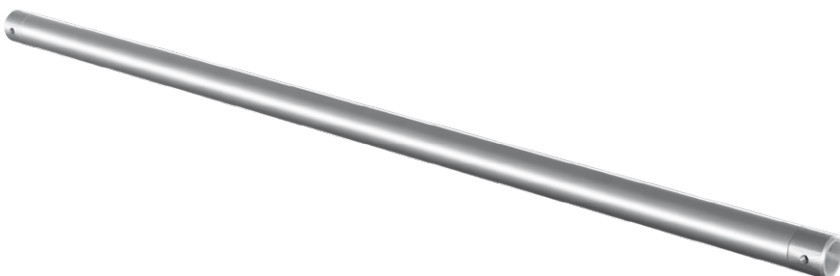

2191

	Multi junction cube
	35 x 35 mm (1.38 x 1.38 in)
	0.3 kg (0.67 lbs)

Includes two connection sets

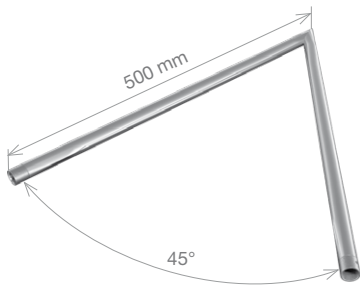

FT21-C19

2-way 45° corner
 0.5 m (1.64 ft)
 0.6 kg (1.36 lbs)

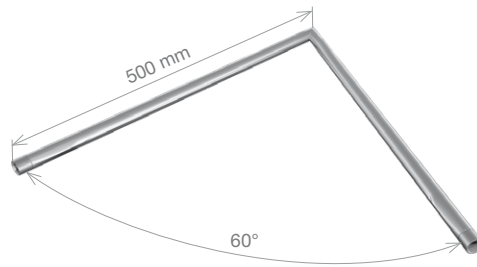

FT21-C20

2-way 60° corner
 0.5 m (1.64 ft)
 0.6 kg (1.36 lbs)

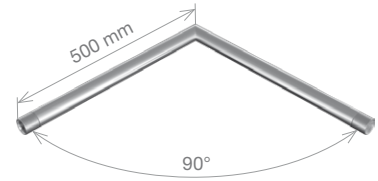

FT21-C21

2-way 90° corner
 0.5 m (1.64 ft)
 0.6 kg (1.36 lbs)

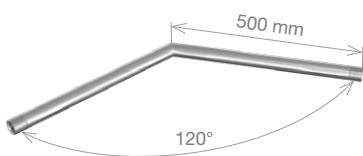

FT21-C22

2-way 120° corner
 0.5 m (1.64 ft)
 0.6 kg (1.36 lbs)

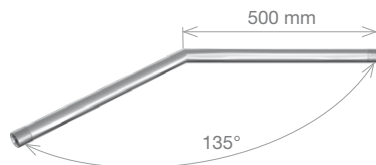

FT21-C23

2-way 135° corner
 0.5 m (1.64 ft)
 0.6 kg (1.36 lbs)

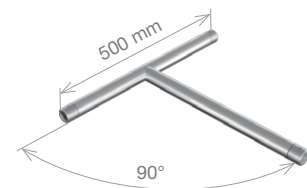

FT21-T35

3-way T-junction
 0.5 m (1.64 ft)
 0.6 kg (1.36 lbs)

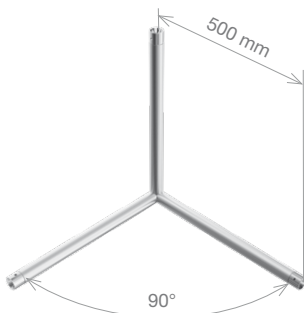

FT21-C30

3-way 90° corner
 0.5 m (1.64 ft)
 0.9 kg (2.00 lbs)



FT21-T40

4-way T-junction
 0.5 m (1.64 ft)
 0.9 kg (2.00 lbs)

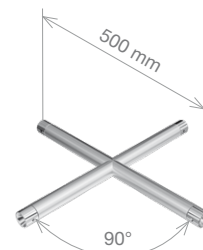

FT21-C41

4-way cross junction
 0.5 m (1.64 ft)
 0.7 kg (1.44 lbs)

SPECIFICATIONS

Tubes	35 x 2 mm (1.38 x 0.08 in)
Braces	8 mm (0.31 in)
Alloy	EN AW-6060 T66

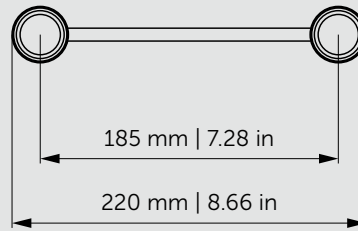

LOADING TABLES

		2 m	3 m	4 m	6 m	8 m	10 m
UDL [kg/m]		101	67	48	21	11	7
Deflection [mm]		0.9	2.9	6.6	15.5	27.7	43.6
CPL [kg]		196	129	96	63	44	33
Deflection [mm]		1.3	3	5.4	12.6	22.9	36.7
		6.56 ft	9.84 ft	13.12 ft	19.68 ft	26.24 ft	32.81 ft
UDL [lbs/ft]		67.9	45	32.3	14.1	7.4	4.7
Deflection [in]		0.04	0.1	0.3	0.6	1.1	1.7
CPL [lbs]		432.2	284.4	211.7	138.9	97	72.8
Deflection [in]		0.1	0.1	0.2	0.5	0.9	1.4

Loading tables are valid for static loads and spans with two supporting points. Spans must be supported at each end.

Contact structural engineer if there are more supporting points applied or dynamic and wind loads involved.

STRAIGHT SEGMENT LENGTHS

Code	Length		Weight	
FT22-50	0.5 m	1.64 ft	0.8 kg	1.79 lbs
FT22-100	1 m	3.28 ft	1.5 kg	3.22 lbs
FT22-150	1.5 m	4.92 ft	2.1 kg	4.70 lbs
FT22-200	2 m	6.56 ft	2.8 kg	6.17 lbs
FT22-250	2.5 m	8.20 ft	3.5 kg	7.61 lbs
FT22-300	3 m	9.84 ft	4.1 kg	9.06 lbs
FT22-350	3.5 m	11.48 ft	4.6 kg	10.23 lbs
FT22-400	4 m	13.12 ft	5.4 kg	12.00 lbs

The listed loads are verified for simply supported beam.

The truss needs to be secured against horizontal movement every 1 m for the loading tables to be valid.

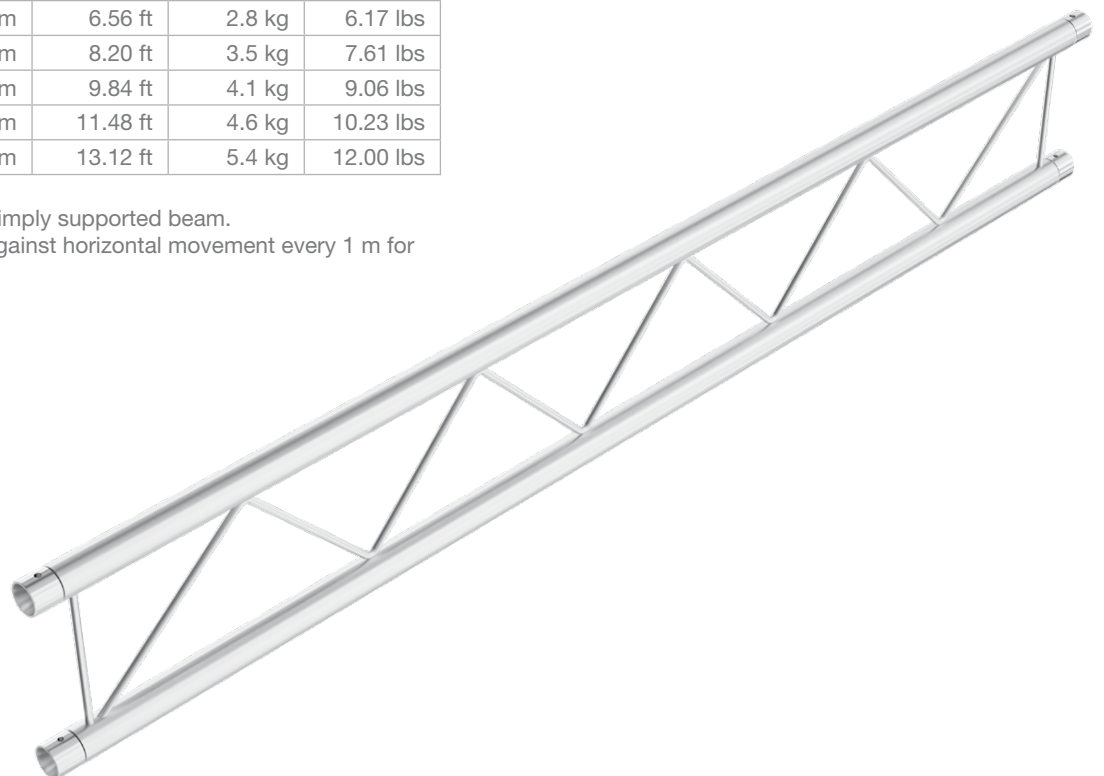

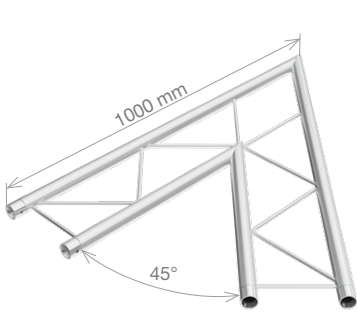

FT22-C19H

2-way 45° horizontal corner
 1 m (3.28 ft)
 2.3 kg (5.09 lbs)

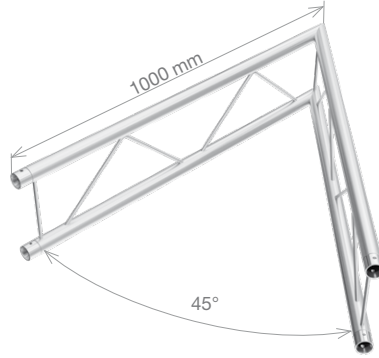

FT22-C19V

2-way 45° vertical corner
 1 m (3.28 ft)
 2.8 kg (6.24 lbs)

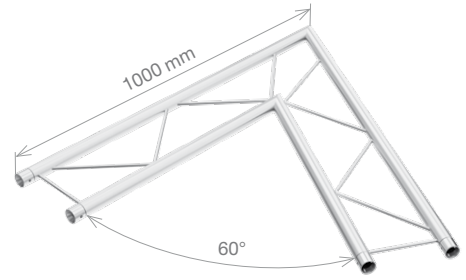

FT22-C20H

2-way 60° horizontal corner
 1 m (3.28 ft)
 2.5 kg (5.40 lbs)

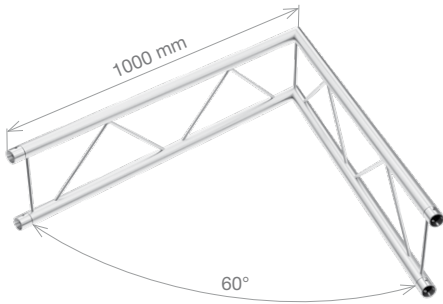

FT22-C20V

2-way 60° vertical corner
 1 m (3.28 ft)
 2.8 kg (6.24 lbs)

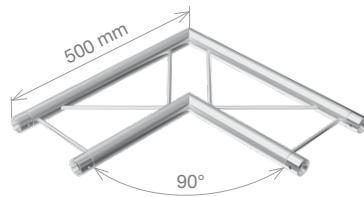

FT22-C21H

2-way 90° horizontal corner
 0.5 m (1.64 ft)
 1.3 kg (2.81 lbs)

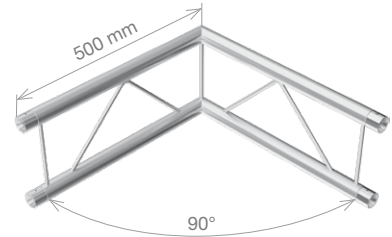

FT22-C21V

2-way 90° vertical corner
 0.5 m (1.64 ft)
 1.5 kg (3.31 lbs)

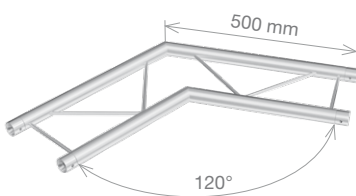

FT22-C22H

2-way 120° horizontal corner
 0.5 m (1.64 ft)
 1.4 kg (3.00 lbs)

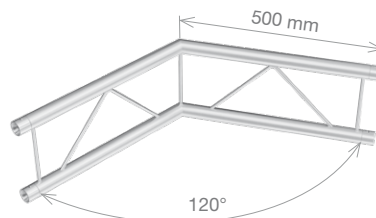

FT22-C22V

2-way 120° vertical corner
 0.5 m (1.64 ft)
 1.5 kg (3.31 lbs)

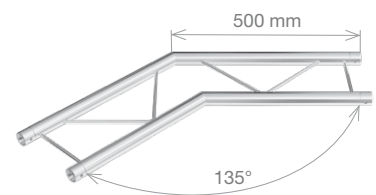

FT22-C23H

2-way 135° horizontal corner
 0.5 m (1.64 ft)
 1.4 kg (3.00 lbs)



FT22

QUICKLOCK LINE

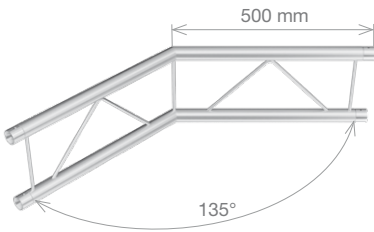
CORNERS



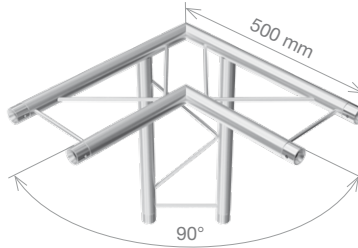

FT22-C23V

 2-way 135° vertical corner
 0.5 m (1.64 ft)
 1.5 kg (3.31 lbs)



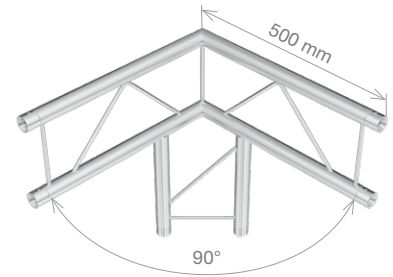

FT22-C30H

 3-way 90° horizontal corner
 0.5 m (1.64 ft)
 2 kg (4.32 lbs)



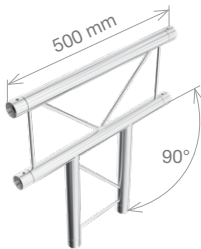

FT22-C30V

 3-way 90° vertical corner
 0.5 m (1.64 ft)
 1.9 kg (4.26 lbs)



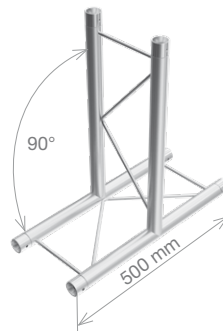

FT22-T35H

 3-way horizontal T-junction
 0.5 m (1.64 ft)
 1.2 kg (2.75 lbs)



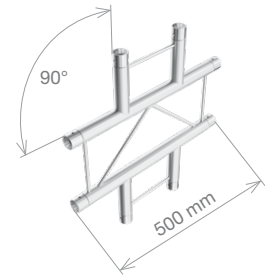

FT22-T35V

 3-way vertical T-junction
 0.5 m (1.64 ft)
 1.5 kg (3.31 lbs)



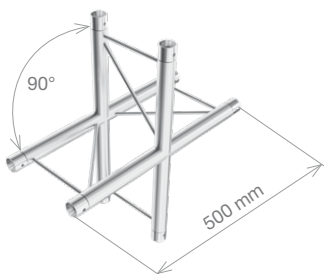

FT22-C41H

 4-way horizontal cross junction
 0.5 m (1.64 ft)
 1.3 kg (2.87 lbs)



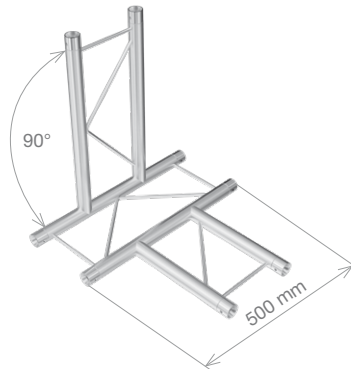

FT22-C41V

 4-way vertical cross junction
 0.5 m (1.64 ft)
 1.5 kg (3.31 lbs)



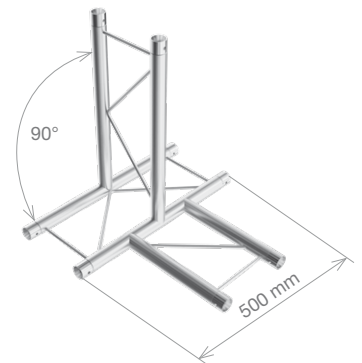

FT22-T42H

 4-way horizontal T-junction
 0.5 m (1.64 ft)
 2.0 kg (4.32 lbs)





FT22-T42V

 4-way vertical T-junction
 0.5 m (1.64 ft)
 2.0 kg (4.32 lbs)

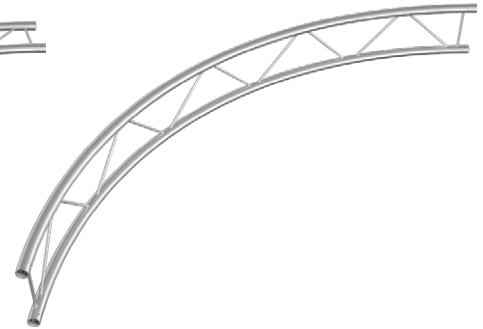
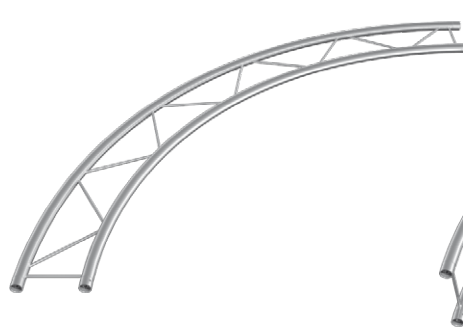
CIRCLES



FT22-21AD

-  FT22-FT21 Adapter
-  0.22 m (0.72 ft)
-  0.5 kg (1.03 lbs)

FT22-CH

-  Horizontal circle,
various diameters

FT22-CV

-  Vertical circle,
various diameters

Includes two connection sets.



SPECIFICATIONS

Tubes	35 x 2 mm (1.38 x 0.08 in)
Braces	8 mm (0.31 in)
Alloy	EN AW-6060 T66

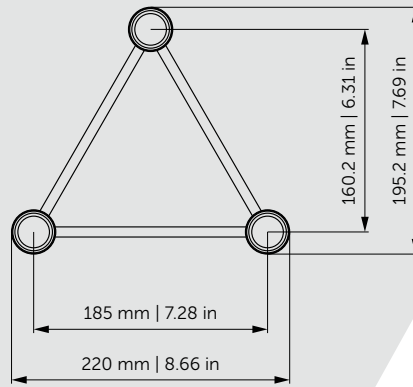

LOADING TABLES

		2 m	3 m	4 m	6 m	8 m	10 m
UDL [kg/m]		175	114	64	27	14	8
Deflection [mm]		1.5	4.9	8.9	20.1	36	56.8
CPL [kg]		262	171	127	81	56	41
Deflection [mm]		1.8	4	7.2	16.5	30	48.3
		6.56 ft	9.84 ft	13.12 ft	19.68 ft	26.24 ft	32.81 ft
UDL [lbs/ft]		117.6	76.6	43	18.1	9.4	5.4
Deflection [in]		0.1	0.2	0.4	0.8	1.4	2.2
CPL [lbs]		577.7	377.1	280	178.6	123.5	90.4
Deflection [in]		0.1	0.2	0.3	0.6	1.2	1.9

Loading tables are valid for static loads and spans with two supporting points. Spans must be supported at each end.

Contact structural engineer if there are more supporting points applied or dynamic and wind loads involved.

STRAIGHT SEGMENT LENGTHS

Code	Length		Weight	
FT23-50	0.5 m	1.64 ft	1.4 kg	3.13 lbs
FT23-100	1 m	3.28 ft	2.5 kg	5.60 lbs
FT23-150	1.5 m	4.92 ft	3.7 kg	8.16 lbs
FT23-200	2 m	6.56 ft	4.9 kg	10.74 lbs
FT23-250	2.5 m	8.20 ft	6.0 kg	13.21 lbs
FT23-300	3 m	9.84 ft	7.1 kg	15.69 lbs
FT23-350	3.5 m	11.48 ft	8.4 kg	18.41 lbs
FT23-400	4 m	13.12 ft	9.4 kg	20.81 lbs

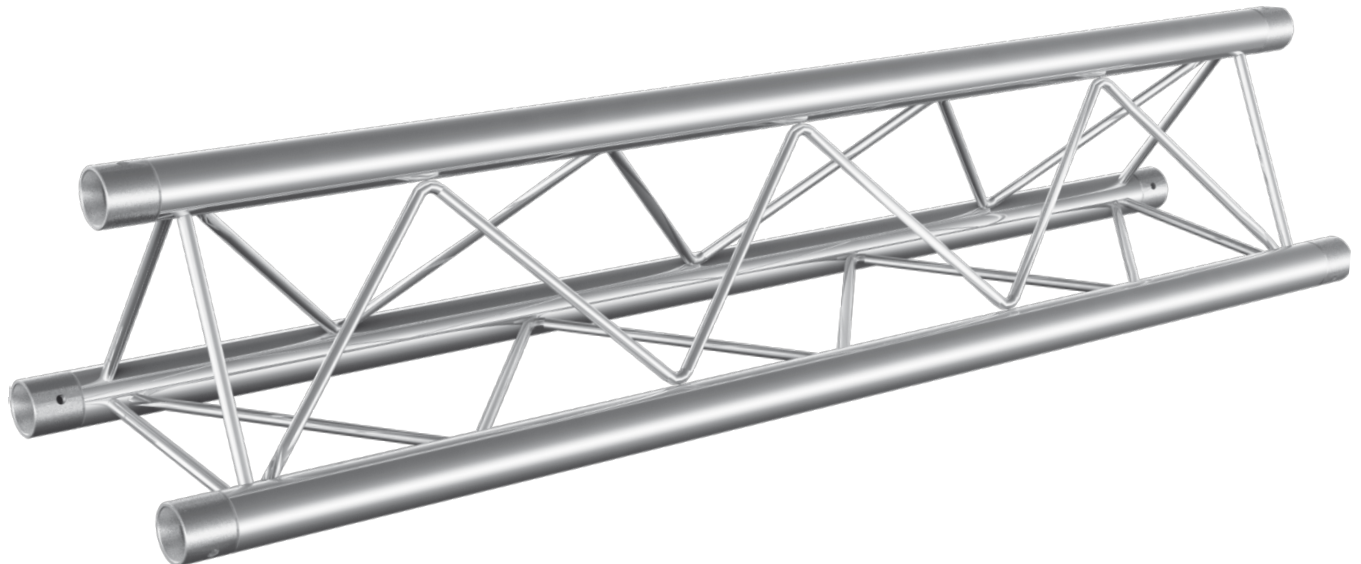

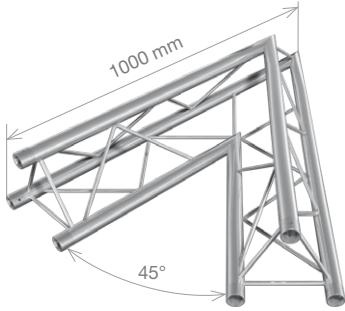

FT23-C19
 2-way 45° corner
 1 m (3.28 ft)
 3.8 kg (8.39 lbs)

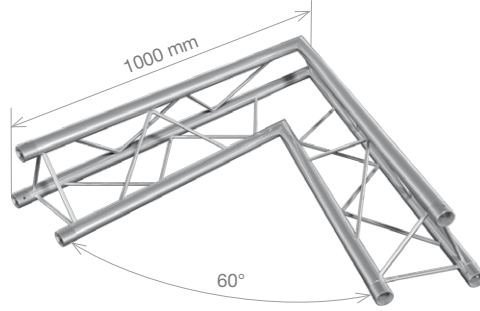

FT23-C20
 2-way 60° corner
 1 m (3.28 ft)
 4.2 kg (9.29 lbs)

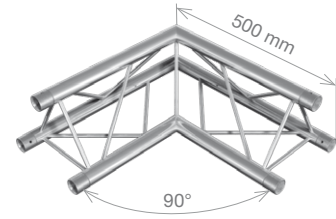

FT23-C21
 2-way 90° corner,
 apex up / down
 0.5 m (1.64 ft)
 2.2 kg (4.82 lbs)

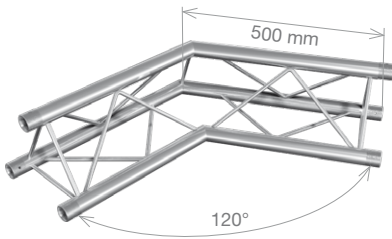

FT23-C22
 2-way 120° corner
 0.5 m (1.64 ft)
 2.4 kg (5.38 lbs)

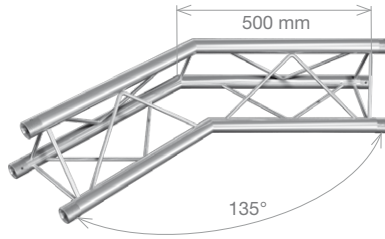

FT23-C23
 2-way 135° corner
 0.5 m (1.64 ft)
 2.5 kg (5.49 lbs)

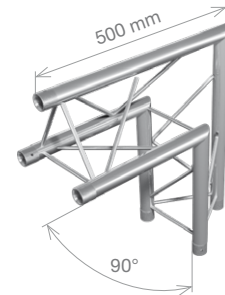

FT23-C24
 2-way 90° corner, apex out
 0.5 m (1.64 ft)
 2.0 kg (4.32 lbs)

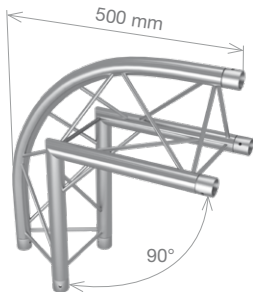

FT23-C24-R
 2-way 90° rounded corner,
 apex out
 0.5 m (1.64 ft)
 2.0 kg (4.32 lbs)

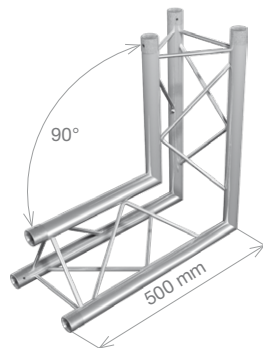

FT23-C25
 2-way 90° corner, apex in
 0.5 m (1.64 ft)
 2.3 kg (4.99 lbs)

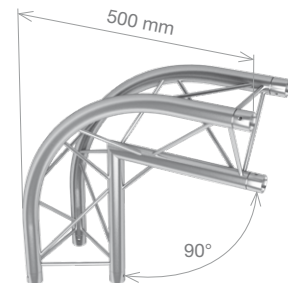

FT23-C25-R
 2-way 90° rounded corner,
 apex in
 0.5 m (1.64 ft)
 2.3 kg (4.99 lbs)



FT23

QUICKLOCK LINE

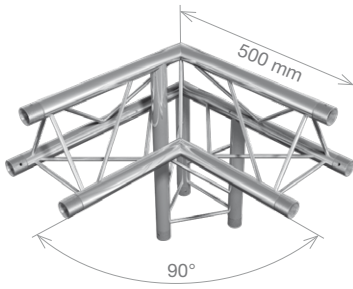
CORNERS



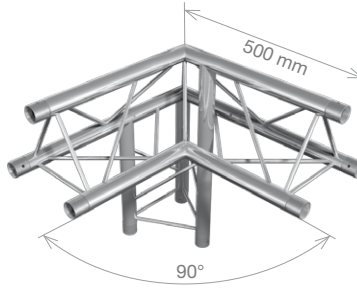

FT23-C31

-  3-way 90° right corner, apex up
-  0.5 m (1.64 ft)
-  3.0 kg (6.72 lbs)



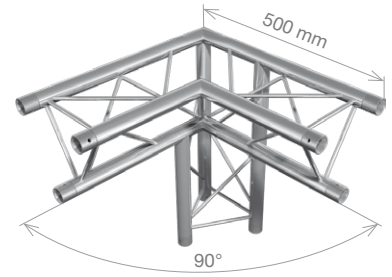

FT23-C32

-  3-way 90° left corner, apex up
-  0.5 m (1.64 ft)
-  3.0 kg (6.72 lbs)



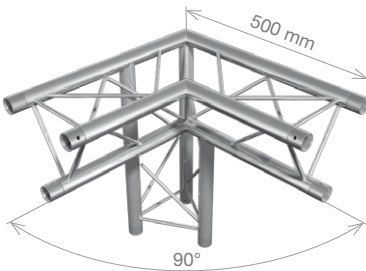

FT23-C33

-  3-way 90° right corner, apex down
-  0.5 m (1.64 ft)
-  3.2 kg (7.07 lbs)



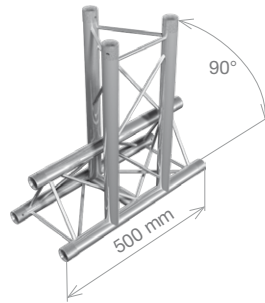

FT23-C34

-  3-way 90° left corner, apex down
-  0.5 m (1.64 ft)
-  3.2 kg (7.07 lbs)



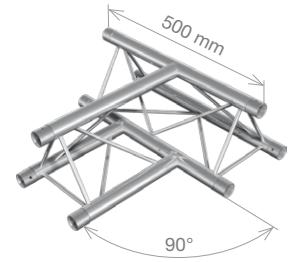

FT23-T35

-  3-way vertical T-junction, apex down
-  0.5 m (1.64 ft)
-  2.6 kg (5.74 lbs)



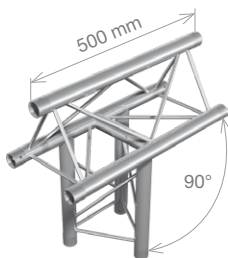

FT23-T36

-  3-way horizontal T-junction
-  0.5 m (1.64 ft)
-  2.2 kg (4.90 lbs)



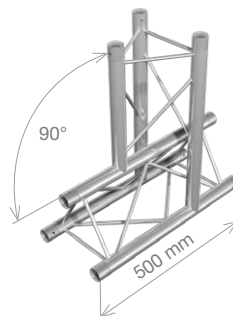

FT23-T37

-  3-way vertical T-junction, apex up
-  0.5 m (1.64 ft)
-  2.3 kg (4.99 lbs)



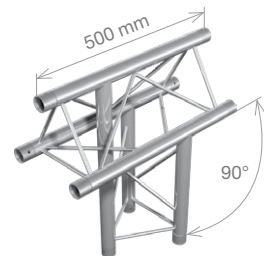

FT23-T38

-  3-way vertical T-junction, apex down
-  0.5 m (1.64 ft)
-  2.4 kg (5.28 lbs)



FT23-T39

-  3-way vertical T-junction
-  0.5 m (1.64 ft)
-  2.3 kg (4.99 lbs)

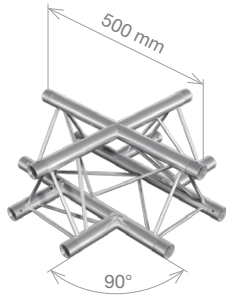

FT23-C41

- 4-way cross junction
- 0.5 m (1.64 ft)
- 2.5 kg (5.47 lbs)

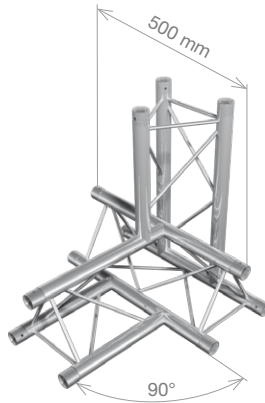

FT23-T42

- 4-way T-junction, apex down
- 0.5 m (1.64 ft)
- 3.2 kg (7.06 lbs)

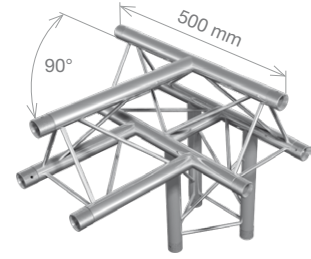

FT23-T43

- 4-way T-junction, apex up
- 0.5 m (1.64 ft)
- 3.0 kg (6.70 lbs)

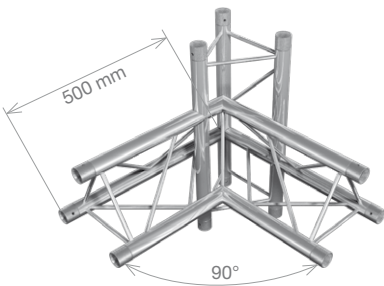

FT23-C44

- 4-way 90° right corner
- 0.5 m (1.64 ft)
- 3.3 kg (7.32 lbs)

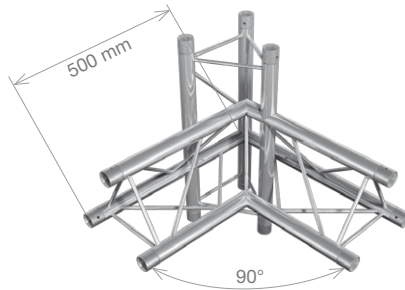

FT23-C45

- 4-way 90° left corner
- 0.5 m (1.64 ft)
- 3.3 kg (7.32 lbs)

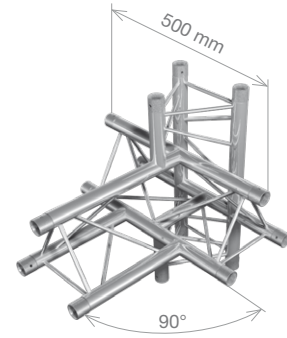

FT23-T51

- 5-way T-junction, apex down
- 0.5 m (1.64 ft)
- 3.3 kg (7.32 lbs)

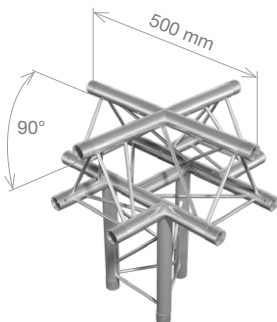

FT23-C52

- 5-way cross junction, apex up
- 0.5 m (1.64 ft)
- 3.3 kg (7.32 lbs)

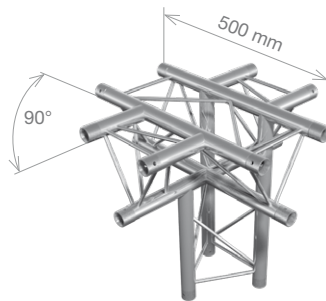

FT23-C53

- 5-way cross junction, apex down
- 0.5 m (1.64 ft)
- 3.4 kg (7.56 lbs)

CIRCLES



FT23-C1



Circle, apex up/down,
various diameters



FT23-C2



Circle, apex in,
various diameters



FT23-C3



Circle, apex out,
various diameters

Various types of coloured powder coating are available for any type of trussing line. Available in RAL range. See samples below.

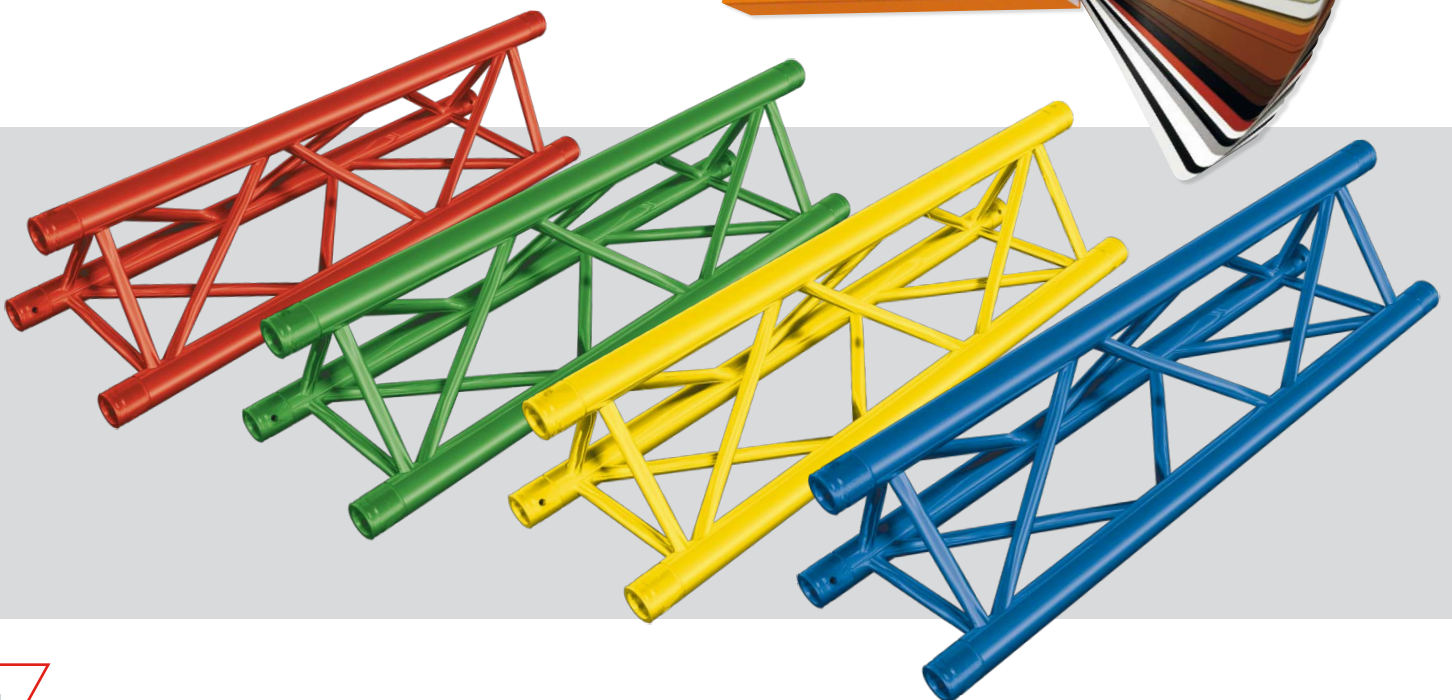



ROBOTIC WELDING IN TAF

We are proud to announce that TAF was the first company in the truss manufacturing industry to introduce automated welding in their production process. Development of this new truss welding robot was carried out over a 2 year period. Although a few minor setbacks were experienced during that time, we managed to reach our goal of having a fully operational robotic welding machine that is capable of extremely precise, serial production of straight truss segments.

The robotic welding station is equipped with Fronius CM welding machines, which carry out MIG welding processes. The station measures 20 x 6 x 4 m (65.62 x 19.69 x 13.12 ft) and is operated by a single, specially trained operator.

There are three KUKA robotic arms in the welding station that are programmed to produce any length (up to 4 m/13.12 ft) of our FT32, HT32, FT34, HT34, and Falconn truss series. The main tubes of the truss are placed into fixed points inside the station by the operator. Preparation of the braces is automated, with their positioning strictly controlled by a laser. As a result, uniform and precise welds are ensured at all times. The automated welding station is also equipped with a cleaning process that eliminates smudges and removes any remaining material after welding is complete, allowing for immediate shipment to clients.

There are several advantages an automated aluminium truss manufacturing process brings

to the table. Truss segments produced at the station are identical and there is very little room for production flaws, such as inconsistent dimensions and welding failures. However, we still follow the high quality standards that TAF has in place and each product that comes out of the robotic welding machine is subjected to stringent visual and mechanical checks for potential discrepancies. The automated welding process is twice as fast as traditional hand welding by our most experienced welders. If we also take into account that the robot can work 24/7, a substantial increase is seen in product output from the factory, which significantly speeds up turnaround. We are therefore able to provide better customer service with lightning fast delivery of high-quality TAF products to their location.

At TAF, we see fast, high-quality manufacturing through automatization, together with high level training of our staff, as the future trend for our production activities. As the first truss manufacturer in the world to introduce a tailored robotic welding station in our production process, we have entered the realm of 4.0 industry and will continue on this path in the coming years. The increased level of efficiency, productivity, and quality provided by this work station is a commitment to our ongoing promise of providing TAF customers with the best products and services in the industry. It is the first, but definitely not the last, step in the innovation of our production line.

SPECIFICATIONS

Tubes	35 x 2 mm (1.38 x 0.08 in)
Braces	8 mm (0.31 in)
Alloy	EN AW-6060 T6

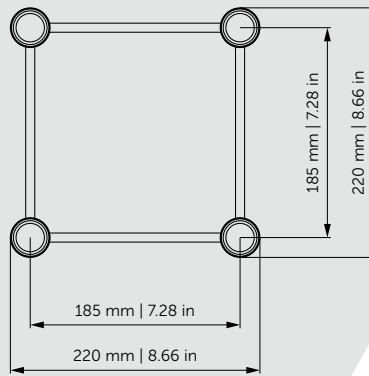

LOADING TABLES

		2 m	3 m	4 m	6 m	8 m	10 m
UDL [kg/m]		202	134	100	65	35	21
Deflection [mm]		0.9	2.9	6.9	23.1	41.3	64.8
CPL [kg]		405	354	286	195	141	107
Deflection [mm]		1.4	4.1	7.9	18.7	33.7	53.6
		6.56 ft	9.84 ft	13.12 ft	19.68 ft	26.24 ft	32.81 ft
UDL [lbs/ft]		135.8	90.1	67.2	43.7	23.5	14.1
Deflection [in]		0	0.1	0.3	0.9	1.6	2.6
CPL [lbs]		893	780.6	630.6	430	310.9	235.9
Deflection [in]		0.1	0.2	0.3	0.7	1.3	2.1

Loading tables are valid for static loads and spans with two supporting points. Spans must be supported at each end.

Contact structural engineer if there are more supporting points applied or dynamic and wind loads involved.

STRAIGHT SEGMENT LENGTHS

Code	Length		Weight	
FT24-50	0.5 m	1.64 ft	1.9 kg	4.18 lbs
FT24-100	1 m	3.28 ft	3.4 kg	7.46 lbs
FT24-150	1.5 m	4.92 ft	4.9 kg	10.88 lbs
FT24-200	2 m	6.56 ft	6.5 kg	14.32 lbs
FT24-250	2.5 m	8.20 ft	8.0 kg	17.61 lbs
FT24-300	3 m	9.84 ft	9.5 kg	20.93 lbs
FT24-350	3.5 m	11.48 ft	11.1 kg	24.55 lbs
FT24-400	4 m	13.12 ft	12.6 kg	27.74 lbs

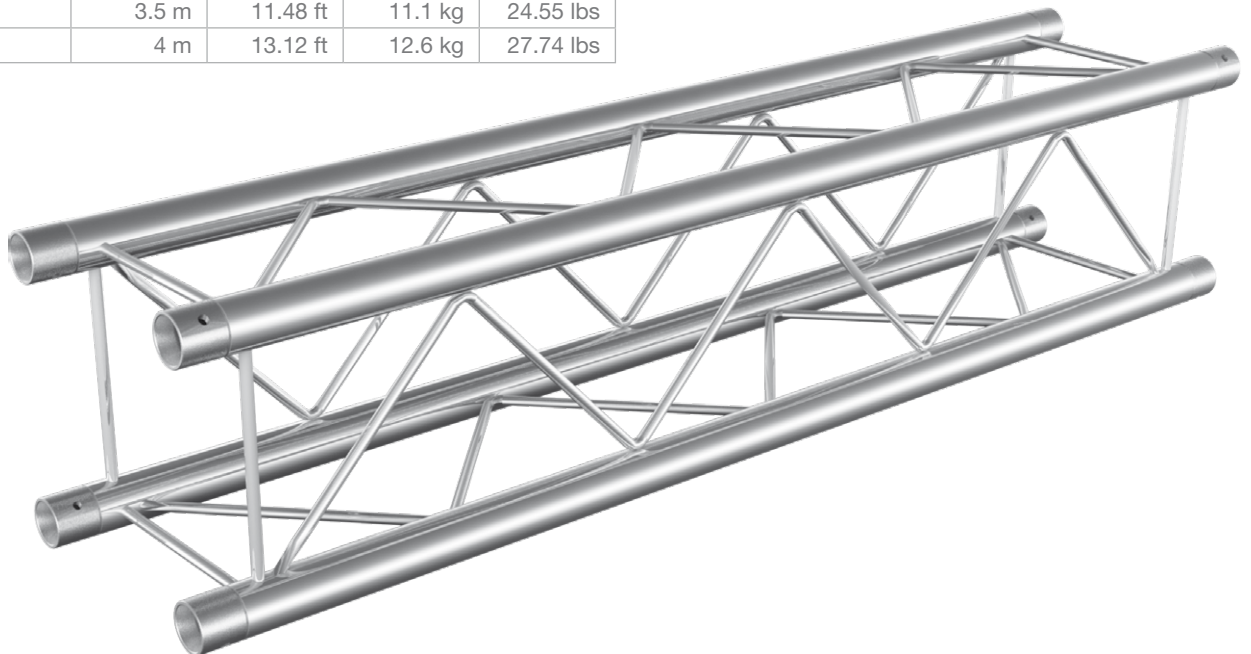

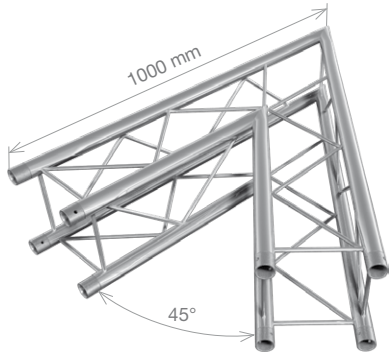

FT24-C19

- 2-way 45° corner
- 1 m (3.28 ft)
- 5.4 kg (11.84 lbs)

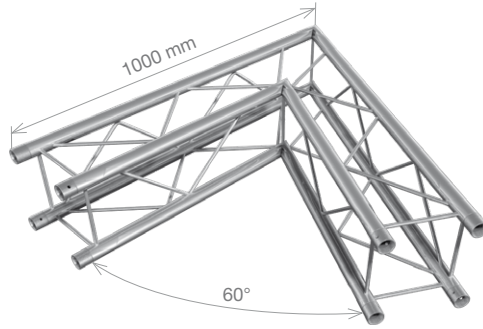

FT24-C20

- 2-way 60° corner
- 1 m (3.28 ft)
- 5.7 kg (12.46 lbs)

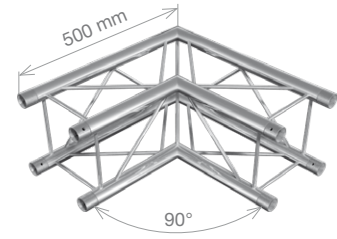

FT24-C21

- 2-way 90° corner
- 0.5 m (1.64 ft)
- 2.9 kg (6.49 lbs)

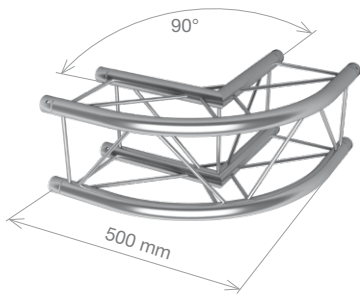

FT24-C21-R

- 2-way 90° rounded corner
- 0.5 m (1.64 ft)
- 2.8 kg (6.14 lbs)

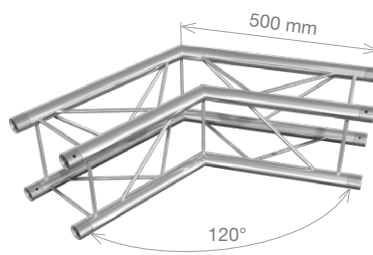

FT24-C22

- 2-way 120° corner
- 0.5 m (1.64 ft)
- 3.1 kg (6.88 lbs)

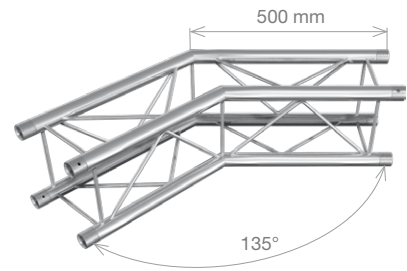

FT24-C23

- 2-way 135° corner
- 0.5 m (1.64 ft)
- 3.3 kg (7.35 lbs)

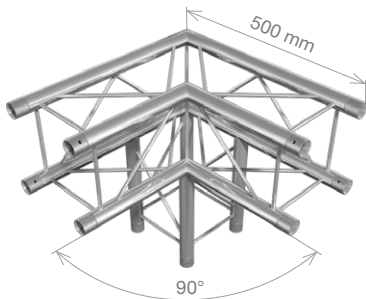

FT24-C30

- 3-way 90° corner
- 0.5 m (1.64 ft)
- 3.9 kg (8.63 lbs)

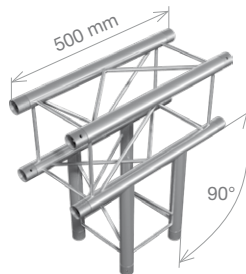

FT24-T35

- 3-way T-junction
- 0.5 m (1.64 ft)
- 2.9 kg (6.49 lbs)

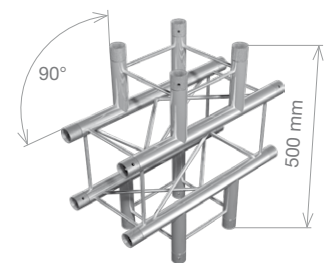

FT24-C41

- 4-way cross junction
- 0.5 m (1.64 ft)
- 3.0 kg (6.58 lbs)

FT24

QUICKLOCK LINE

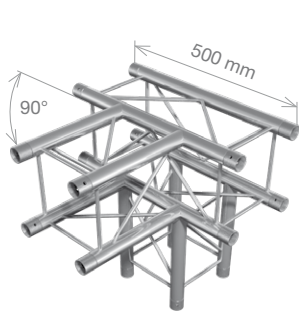

FT24-T42

- 4-way 90° corner
- 0.5 m (1.64 ft)
- 3.9 kg (8.52 lbs)

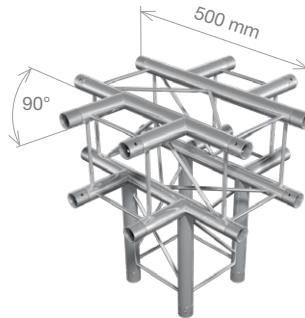

FT24-C55

- 5-way T-junction
- 0.5 m (1.64 ft)
- 4.0 kg (8.71 lbs)

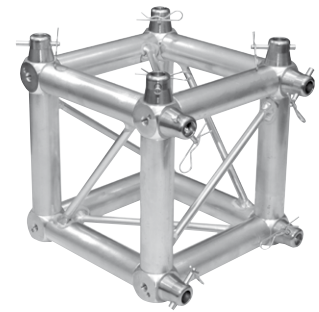

FT24-MCB

- Multi connection box
- 0.22 x 0.22 m (0.72 x 0.72 ft)
- 4.9 kg (10.90 lbs)

Includes connection sets for two ways.

CIRCLES



FT24-C

- Circle, various diameters

EXPANDING THE LIMITS OF “LIGHT-DUTY”

Our FT20 “light-duty” truss line packs a powerful punch in providing extra strong and safe support for your small to medium-sized indoor/outdoor structures with lighter loading requirements, such as exhibition booths, retail displays, DJ booths, stands, frames and other decorative applications.

All FT20 truss features the Quicklock connection system for quick and easy assembly, and is TÜV SÜD certified.





2112

Connection set for FT21



2124

Connection set for FT22



2135

Connection set for FT23



2146

Connection set for FT24



2101

Conical connector, diam. 30 mm (1.18 in), FT21-24



2150

Pin for FT21-24



2152

Safety clip for FT21-24



2110

Aluminium male halfconnector with M8 thread, FT21-24



2116

Steel halfconnector with M8 thread, FT21-24



2151

Steel pin with thread, FT21-24



2109

Endcap for FT21-24



2002

Male base plate for FT22

2002/W

Male wall plate for FT22

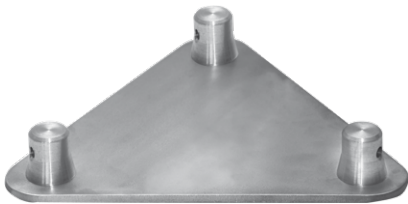

2003

Male base plate for FT23

2003/W

Male wall plate for FT23



2004

Male base plate for FT24

2004/W

Male wall plate for FT24



2190

Hinge for FT21-24

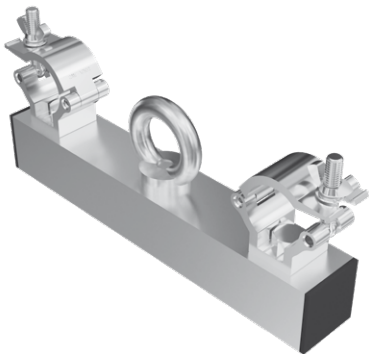

8040

Truss holder for FT21-FT24

SPECIFICATIONS

Tubes	50 x 2 mm (1.97 x 0.08 in)
Alloy	EN AW-6082 T6

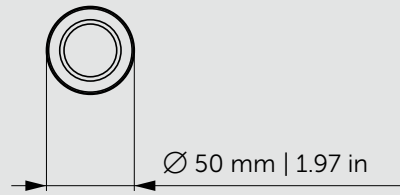

LOADING TABLES

		1 m	2 m	3 m	4 m
UDL [kg/m]		438	109	49	27
Deflection [mm]		9.4	37.4	84.2	149.7
CPL [kg]		219	109	73	55
Deflection [mm]		7.5	29.9	67.4	119.8
		3.28 ft	6.56 ft	9.84 ft	13.12 ft
UDL [lbs/ft]		294.4	73.3	32.9	18.1
Deflection [in]		0.4	1.5	3.3	5.9
CPL [lbs]		482.9	240.3	161	121.3
Deflection [in]		0.3	1.2	2.7	4.7

Loading tables are valid for static loads and spans with two supporting points.

Spans must be supported at each end.

Contact structural engineer if there are more supporting points applied or dynamic and wind loads involved.

STRAIGHT SEGMENT LENGTHS

Code	Length		Weight	
FT31-50	0.5 m	1.64 ft	0.7 kg	1.55 lbs
FT31-100	1 m	3.28 ft	1.1 kg	2.44 lbs
FT31-150	1.5 m	4.92 ft	1.5 kg	3.35 lbs
FT31-200	2 m	6.56 ft	1.9 kg	4.25 lbs
FT31-250	2.5 m	8.20 ft	2.3 kg	5.15 lbs
FT31-300	3 m	9.84 ft	2.7 kg	6.06 lbs
FT31-350	3.5 m	11.48 ft	3.2 kg	6.96 lbs
FT31-400	4 m	13.12 ft	3.6 kg	7.87 lbs
FT31-500	5 m	16.40 ft	4.4 kg	9.67 lbs



3191

Multi junction cube
 0.7 kg (1.65 lbs)

Includes connection sets for two ways.

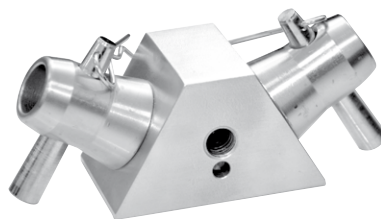

3192

Multi junction cube 120°
 0.7 kg (1.65 lbs)

Includes connection sets for two ways.

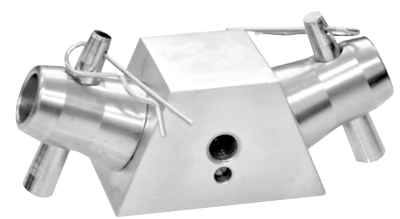

3193

Multi junction cube 135°
 0.8 kg (1.75 lbs)

Includes connection sets for two ways.



FT31-C19

2-way 45° corner
 0.5 m (1.64 ft)
 1.1 kg (2.44 lbs)

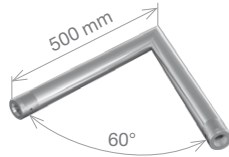

FT31-C20

2-way 60° corner
 0.5 m (1.64 ft)
 1.1 kg (2.44 lbs)

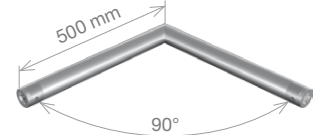

FT31-C21

2-way 90° corner
 0.5 m (1.64 ft)
 1.1 kg (2.44 lbs)

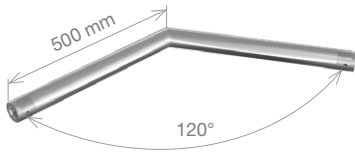

FT31-C22

2-way 120° corner
 0.5 m (1.64 ft)
 1.1 kg (2.44 lbs)

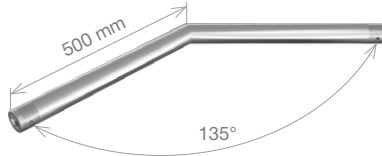

FT31-C23

2-way 135° corner
 0.5 m (1.64 ft)
 1.1 kg (2.44 lbs)



FT31-C30

3-way 90° corner
 0.5 m (1.64 ft)
 1.6 kg (3.59 lbs)

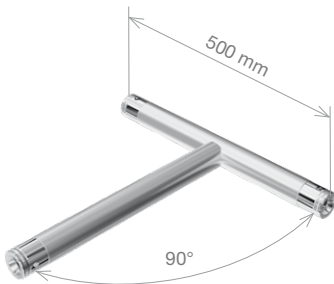

FT31-T35

3-way T-junction
 0.5 m (1.64 ft)
 1.2 kg (2.69 lbs)



FT31-T42

4-way T-junction
 0.5 m (1.64 ft)
 1.7 kg (3.84 lbs)

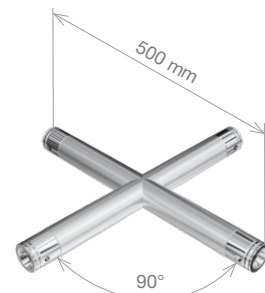

FT31-C41

4-way cross junction
 0.5 m (1.64 ft)
 1.4 kg (3.03 lbs)

SPECIFICATIONS

Tubes	50 x 2 mm (1.97 x 0.08 in)
Braces	20 x 2 mm (0.79 x 0.08 in)
Alloy	EN AW-6082 T6

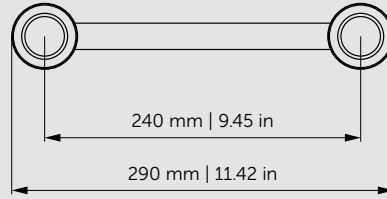

LOADING TABLES

		2 m	4 m	6 m	8 m	10 m	12 m
UDL [kg/m]		673	166	76	43	27	18
Deflection [mm]		2.3	9.3	21.9	39.8	63.7	94
CPL [kg]		673	333	228	170	135	110
Deflection [mm]		1.9	7.4	17.6	32.3	52.5	77.7
		6.56 ft	13.12 ft	19.68 ft	26.24 ft	32.81 ft	39.37 ft
UDL [lbs/ft]		452.3	111.6	51.1	28.9	18.1	12.1
Deflection [in]		0.1	0.4	0.9	1.6	2.5	3.7
CPL [lbs]		1484	734.3	502.7	374.9	297.7	242.6
Deflection [in]		0.1	0.3	0.7	1.3	2.1	3.1

Loading tables are valid for static loads and spans with two supporting points.

Spans must be supported at each end.

Contact structural engineer if there are more supporting points applied or dynamic and wind loads involved.

The truss needs to be secured against horizontal movement every 1 m for the loading tables to be valid.

STRAIGHT SEGMENT LENGTHS

Code	Length		Weight	
FT32-50	0.5 m	1.64 ft	1.7 kg	3.66 lbs
FT32-100	1 m	3.28 ft	2.6 kg	5.79 lbs
FT32-150	1.5 m	4.92 ft	3.6 kg	8.00 lbs
FT32-200	2 m	6.56 ft	4.6 kg	10.21 lbs
FT32-250	2.5 m	8.20 ft	5.6 kg	12.41 lbs
FT32-300	3 m	9.84 ft	6.6 kg	14.62 lbs
FT32-350	3.5 m	11.48 ft	7.6 kg	16.83 lbs
FT32-400	4 m	13.12 ft	8.6 kg	19.04 lbs
FT32-450	4.5 m	14.76 ft	9.6 kg	21.25 lbs
FT32-500	5 m	16.40 ft	10.6 kg	23.46 lbs

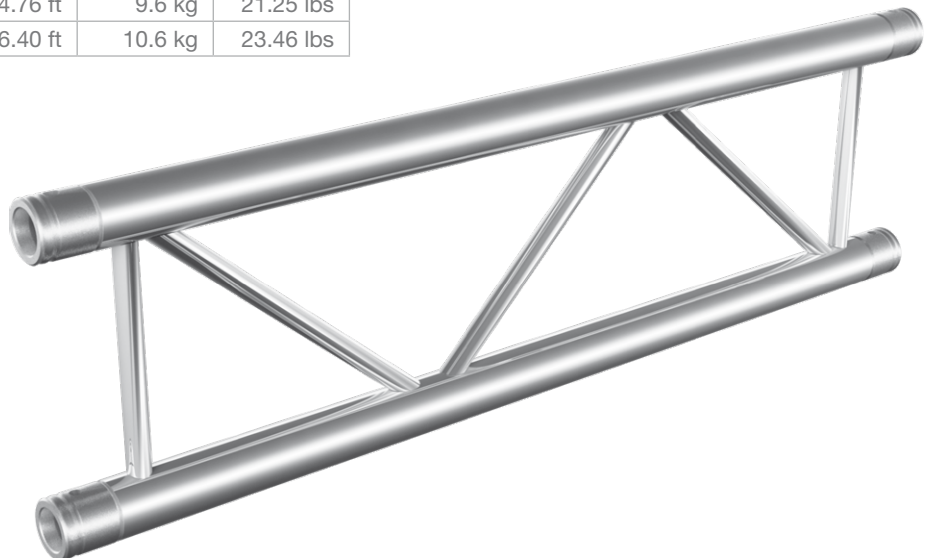

SPECIFICATIONS

Tubes	50 x 3 mm (1.97 x 0.12 in)
Braces	20 x 2 mm (0.79 x 0.08 in)
Alloy	EN AW-6082 T6

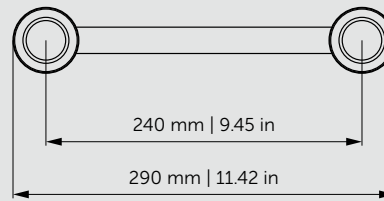

LOADING TABLES

		2 m	4 m	6 m	8 m	10 m	12 m
UDL [kg/m]		710	254	115	64	40	27
Deflection [mm]		1.7	9.6	22.3	40.4	64.2	94.1
CPL [kg]		1027	508	344	256	202	165
Deflection [mm]		1.9	7.7	18	32.8	52.5	77.5
		6.56 ft	13.12 ft	19.68 ft	26.24 ft	32.81 ft	39.37 ft
UDL [lbs/ft]		477.2	170.7	77.3	43	26.9	18.1
Deflection [in]		0.1	0.4	0.9	1.6	2.5	3.7
CPL [lbs]		2264.5	1120.1	758.5	564.5	445.4	363.8
Deflection [in]		0.1	0.3	0.7	1.3	2.1	3.1

Loading tables are valid for static loads and spans with two supporting points.

Spans must be supported at each end.

Contact structural engineer if there are more supporting points applied or dynamic and wind loads involved.

The truss needs to be secured against horizontal movement every 1 m for the loading tables to be valid.

STRAIGHT SEGMENT LENGTHS

Code	Length		Weight	
	m	ft	kg	lbs
HT32-50	0.5 m	1.64 ft	1.9 kg	4.25 lbs
HT32-100	1 m	3.28 ft	3.3 kg	7.22 lbs
HT32-150	1.5 m	4.92 ft	4.7 kg	10.27 lbs
HT32-200	2 m	6.56 ft	6.0 kg	13.32 lbs
HT32-250	2.5 m	8.20 ft	7.4 kg	16.36 lbs
HT32-300	3 m	9.84 ft	8.8 kg	19.41 lbs
HT32-350	3.5 m	11.48 ft	10.2 kg	22.46 lbs
HT32-400	4 m	13.12 ft	11.6 kg	25.51 lbs
HT32-450	4.5 m	14.76 ft	13.0 kg	28.55 lbs
HT32-500	5 m	16.40 ft	15.5 kg	34.16 lbs

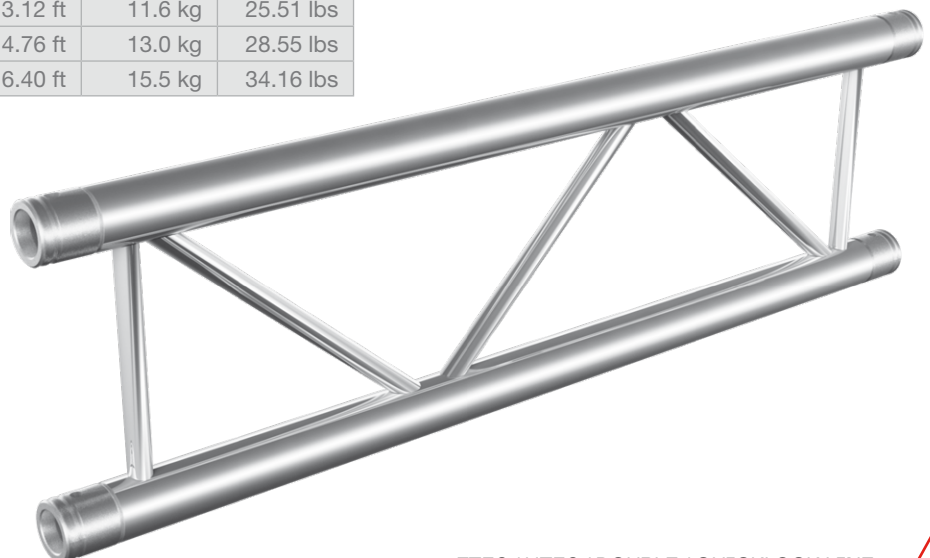

FT32 / HT32

QUICKLOCK LINE

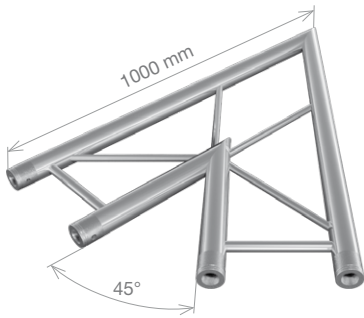

FT32-C19H		HT32-C19H	
	2-way 45° horizontal corner 1 m (3.28 ft)		
	4.0 kg (8.79 lbs)		5.2 kg (11.56 lbs)

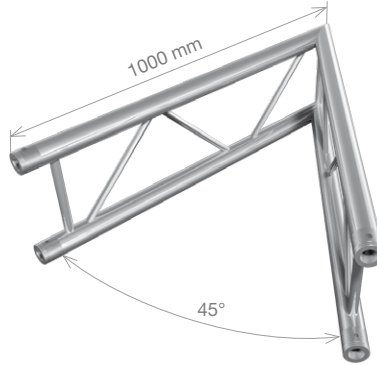

FT32-C19V		HT32-C19V	
	2-way 45° vertical corner 1 m (3.28 ft)		
	4.6 kg (10.07 lbs)		6.0 kg (13.18 lbs)

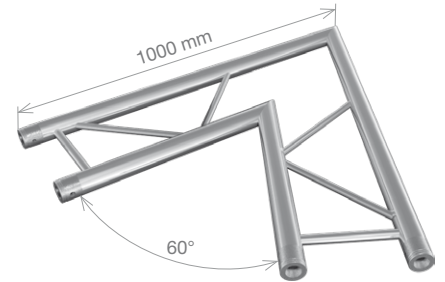

FT32-C20H		HT32-C20H	
	2-way 60° horizontal corner 1 m (3.28 ft)		
	3.7 kg (8.26 lbs)		4.8 kg (10.68 lbs)

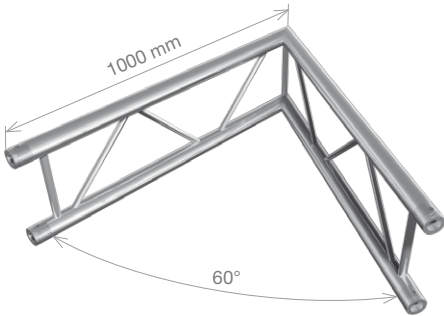

FT32-C20V		HT32-C20V	
	2-way 60° vertical corner 1 m (3.28 ft)		
	4.6 kg (10.07 lbs)		6.0 kg (13.18 lbs)

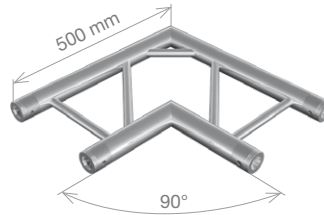

FT32-C21H		HT32-C21H	
	2-way 90° horizontal corner 0.5 m (1.64 ft)		
	2.2 kg (4.78 lbs)		2.6 kg (5.67 lbs)

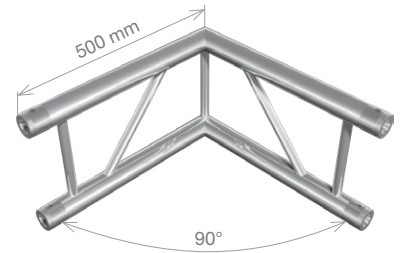

FT32-C21V		HT32-C21V	
	2-way 90° vertical corner 0.5 m (1.64 ft)		
	2.6 kg (5.67 lbs)		3.2 kg (7.11 lbs)

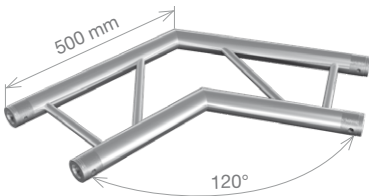

FT32-C22H		HT32-C22H	
	2-way 120° horizontal corner 0.5 m (1.64 ft)		
	2.3 kg (4.99 lbs)		2.5 kg (5.49 lbs)

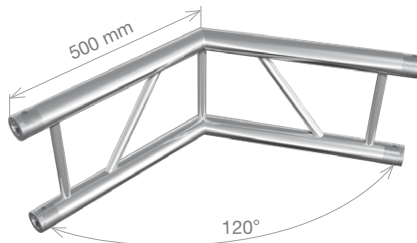

FT32-C22V		HT32-C22V	
	2-way 120° vertical corner 0.5 m (1.64 ft)		
	2.6 kg (5.67 lbs)		2.5 kg (5.49 lbs)

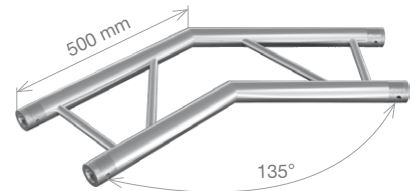

FT32-C23H		HT32-C23H	
	2-way 135° horizontal corner 0.5 m (1.64 ft)		
	2.3 kg (4.99 lbs)		2.6 kg (5.67 lbs)

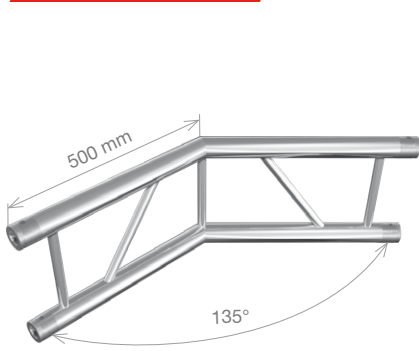

FT32-C23V		HT32-C23V	
	2-way 135° vertical corner 0.5 m (1.64 ft)		
	2.5 kg (5.60 lbs)		2.6 kg (5.67 lbs)



FT32-C30H		HT32-C30H	
	3-way 90° horizontal corner 0.5 m (1.64 ft)		
	3.4 kg (7.41 lbs)		4.1 kg (9.09 lbs)

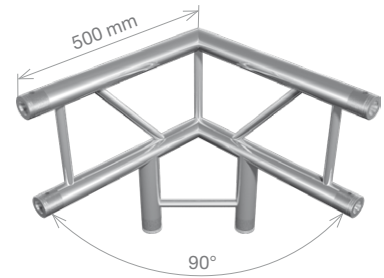

FT32-C30V		HT32-C30V	
	3-way 90° vertical corner 0.5 m (1.64 ft)		
	3.3 kg (7.32 lbs)		4.1 kg (9.09 lbs)

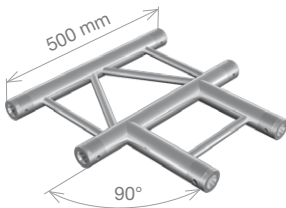

FT32-T35H		HT32-T35H	
	3-way horizontal T-junction 0.5 m (1.64 ft)		
	2.4 kg (5.35 lbs)		2.8 kg (6.21 lbs)

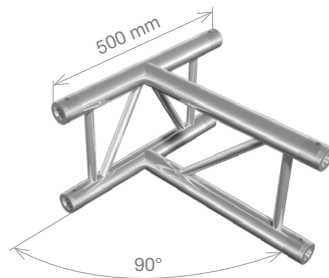

FT32-T35V		HT32-T35V	
	3-way vertical T-junction 0.5 m (1.64 ft)		
	2.9 kg (6.39 lbs)		3.5 kg (7.63 lbs)

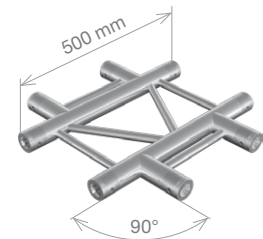

FT32-C41H		HT32-C41H	
	4-way horizontal cross junction 0.5 m (1.64 ft)		
	2.7 kg (6.01 lbs)		3.1 kg (6.75 lbs)

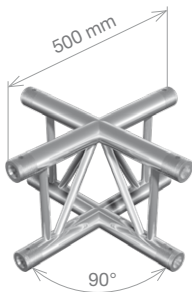

FT32-C41V		HT32-C41V	
	4-way vertical cross junction 0.5 m (1.64 ft)		
	3.3 kg (7.32 lbs)		3.8 kg (8.33 lbs)



FT32-T42H		HT32-T42H	
	4-way horizontal T-junction 0.5 m (1.64 ft)		
	3.7 kg (8.10 lbs)		4.4 kg (9.64 lbs)

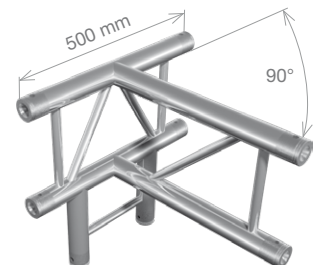

FT32-T42V		HT32-T42V	
	4-way vertical T-junction 0.5 m (1.64 ft)		
	3.7 kg (8.10 lbs)		4.4 kg (9.64 lbs)

FT32 / HT32

QUICKLOCK LINE

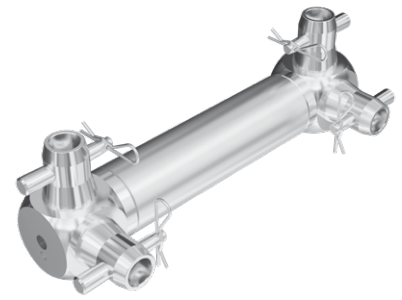
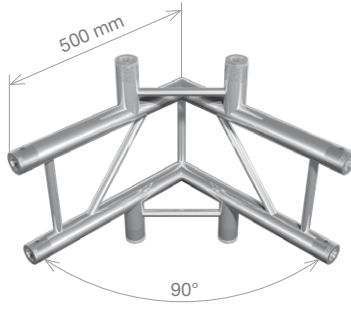
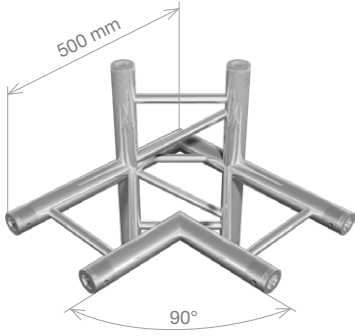

FT32-C44H

HT32-C44H



4-way 90° horizontal corner
0.5 m (1.64 ft)



3.8 kg
(8.33 lbs)

3.8 kg
(8.33 lbs)

FT32-C44V

HT32-C44V



4-way 90° vertical corner
0.5 m (1.64 ft)



3.6 kg
(8.04 lbs)

3.6 kg
(8.04 lbs)

FT32-31AD

HT32-31AD



FT32-FT31 Adapter /
HT32HT31 Adapter
0.29 m (0.95 ft)



0.7 kg
(1.65 lbs)

2.0 kg
(4.32 lbs)

Includes connection sets for two ways.

CIRCLES

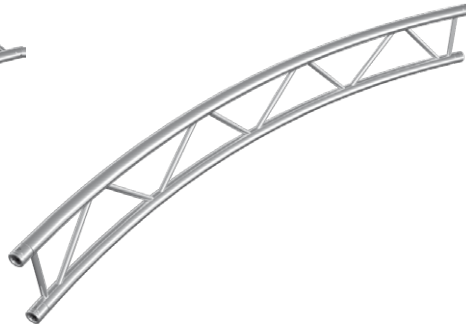
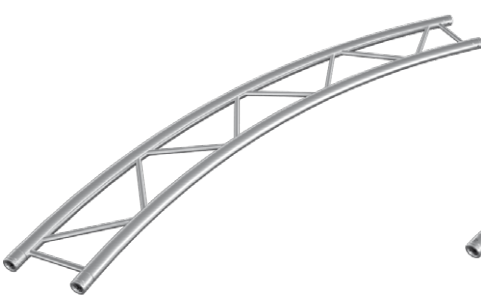

FT32-CH

HT32-CH



Horizontal circle,
various diameters

FT32-CV

HT32-CV



Vertical circle,
various diameters

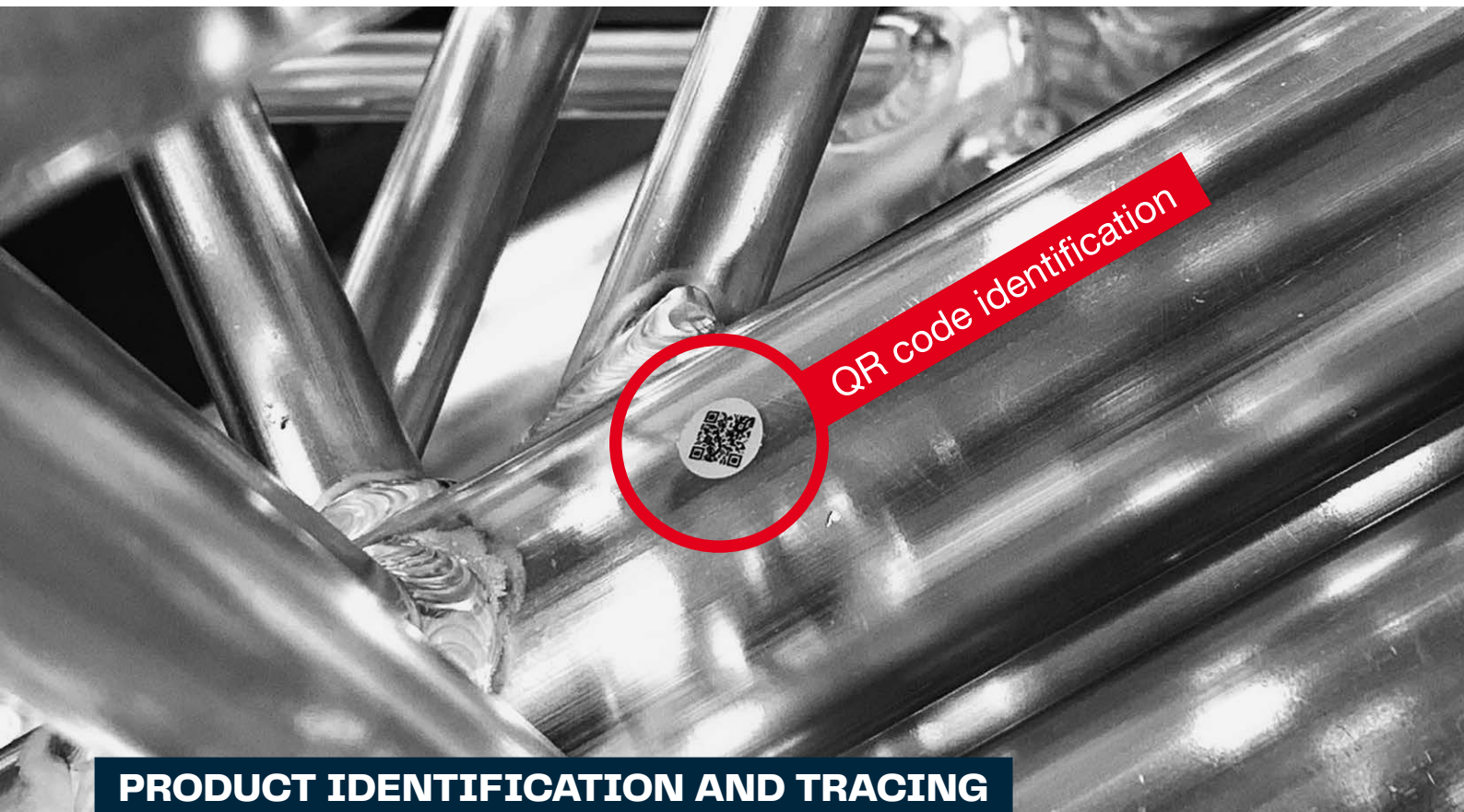

PRODUCT IDENTIFICATION AND TRACING

It has become standard practice throughout the EU to properly label each product, so the materials, welding procedure, quality control, and final packaging are traceable. There are several ways how this can be achieved.

Firstly, in order to identify a product has been made by TAF, we use thermo labels with our logo on products that lists all basic information, such as product type, date of expedition, QC name or abbreviation, name of the quality manager, all certificate logos for the specific product, TAF website address, and address of the factory.

Logos you can find on our product labels include CE, TUV, and GSI SLV, with all confirming the product was made, tested, and certified in accordance with EU standards.

In addition to this TAF label, we use a smaller sticker on each piece of truss or product manufactured in our company that contains a unique QR code that can be read by almost any mobile phone. The QR code immediately provides customers with information about the product, which can then be sent to us for tracking its manufacturing process.

This unique QR code contains a set of numbers that makes it possible for us to identify the production history of each product - from the very beginning of the production process all the way up to its final packaging.

As a result, we are able to precisely track the batch of material used for its production and match it with the proper material certificate, identify people involved in material preparation, the welding process, quality control, and the person who packaged it at the end. The embedded production plan number basically gives us a complete view of the product's manufacturing history.

Reading the QR code is the quickest and easiest method of tracking a product's manufacturing process. This small identification tool can save the day if the main label is lost, damaged or removed.



SPECIFICATIONS

Tubes	50 x 2 mm (1.97 x 0.08 in)
Braces	20 x 2 mm (0.79 x 0.08 in)
Alloy	EN AW-6082 T6

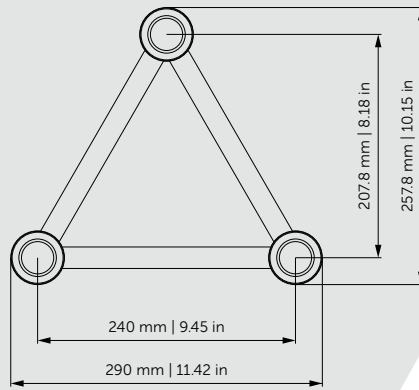

LOADING TABLES

		2 m	4 m	6 m	8 m	10 m	12 m
UDL [kg/m]		761	206	92	51	31	20
Deflection [mm]		2.6	11.5	26.8	48.8	75.2	105.6
CPL [kg]		761	412	277	206	154	117
Deflection [mm]		2.1	9.3	21.7	39.8	62	88.3
		6.56 ft	13.12 ft	19.68 ft	26.24 ft	32.81 ft	39.37 ft
UDL [lbs/ft]		511.4	138.4	61.8	34.3	20.8	13.4
Deflection [in]		0.1	0.5	1.1	1.9	3	4.2
CPL [lbs]		1678	908.5	610.8	454.2	339.6	258
Deflection [in]		0.1	0.4	0.9	1.6	2.4	3.5

Loading tables are valid for static loads and spans with two supporting points.

Spans must be supported at each end.

Contact structural engineer if there are more supporting points applied or dynamic and wind loads involved.

STRAIGHT SEGMENT LENGTHS

Code	Length		Weight	
FT33-50	0.5 m	1.64 ft	2.9 kg	6.32 lbs
FT33-100	1 m	3.28 ft	4.6 kg	10.03 lbs
FT33-150	1.5 m	4.92 ft	6.3 kg	13.95 lbs
FT33-200	2 m	6.56 ft	8.1 kg	17.86 lbs
FT33-250	2.5 m	8.20 ft	9.9 kg	21.78 lbs
FT33-300	3 m	9.84 ft	11.7 kg	25.69 lbs
FT33-350	3.5 m	11.48 ft	13.4 kg	29.61 lbs
FT33-400	4 m	13.12 ft	15.2 kg	33.53 lbs
FT33-450	4.5 m	14.76 ft	17.0 kg	37.44 lbs
FT33-500	5 m	16.40 ft	18.8 kg	41.36 lbs

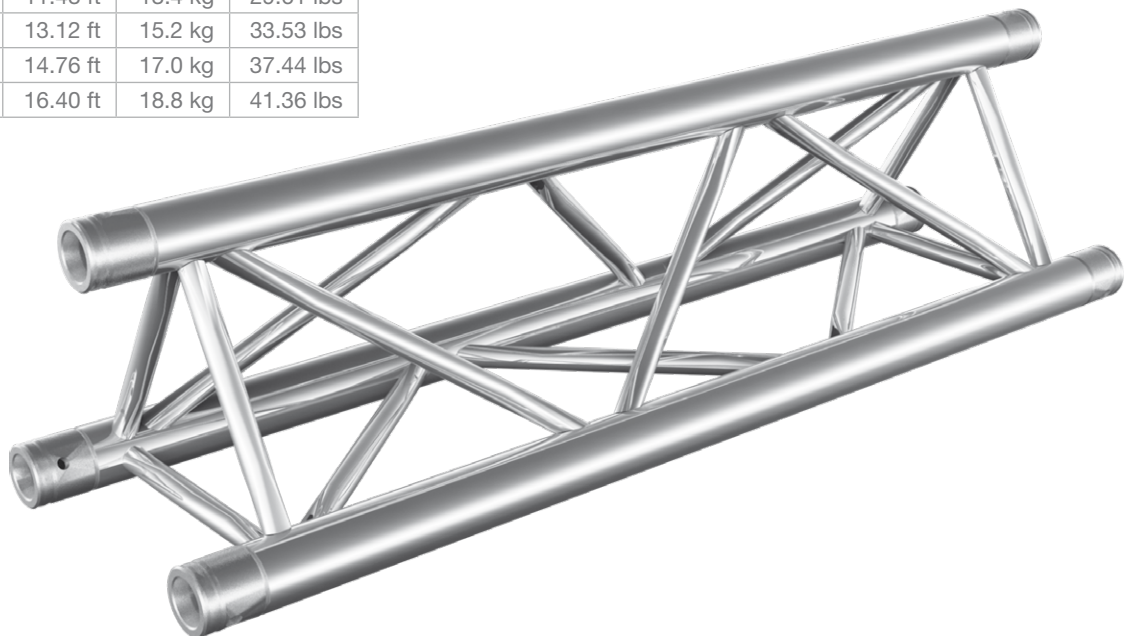

SPECIFICATIONS

Tubes	50 x 3 mm (1.97 x 0.12 in)
Braces	20 x 2 mm (0.79 x 0.08 in)
Alloy	EN AW-6082 T6

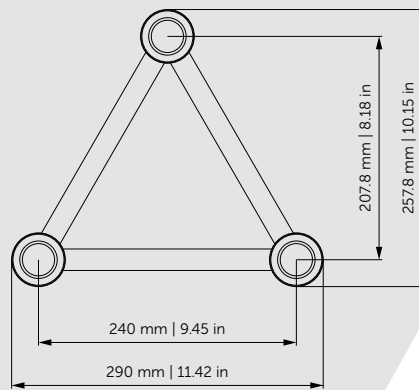

LOADING TABLES

		2 m	4 m	6 m	8 m	10 m	12 m
UDL [kg/m]		1231	338	150	81	50	32
Deflection [mm]		2.9	12.8	29.4	51.7	80.6	112.7
CPL [kg]		1321	675	450	324	249	190
Deflection [mm]		2.5	10.3	23.7	42.1	66.1	93.5
		6.56 ft	13.12 ft	19.68 ft	26.24 ft	32.81 ft	39.37 ft
UDL [lbs/ft]		827.3	227.2	100.8	54.4	33.6	21.5
Deflection [in]		0.1	0.5	1.2	2	3.2	4.4
CPL [lbs]		2912.8	1488.4	992.3	714.4	549	419
Deflection [in]		0.1	0.4	0.9	1.7	2.6	3.7

Loading tables are valid for static loads and spans with two supporting points.

Spans must be supported at each end.

Contact structural engineer if there are more supporting points applied or dynamic and wind loads involved.

STRAIGHT SEGMENT LENGTHS

Code	Length		Weight	
HT33-50	0.5m	1.64 ft	3.3 kg	7.22 lbs
HT33-100	1 m	3.28 ft	5.5 kg	12.19 lbs
HT33-150	1.5 m	4.92 ft	7.9 kg	17.36 lbs
HT33-200	2 m	6.56 ft	10.2 kg	22.53 lbs
HT33-250	2.5 m	8.20 ft	12.6 kg	27.71 lbs
HT33-300	3 m	9.84 ft	14.9 kg	32.88 lbs
HT33-350	3.5 m	11.48 ft	17.3 kg	38.05 lbs
HT33-400	4 m	13.12 ft	19.6 kg	43.22 lbs
HT33-450	4.5 m	14.76 ft	22.0 kg	48.39 lbs
HT33-500	5 m	16.40 ft	24.3 kg	53.57 lbs

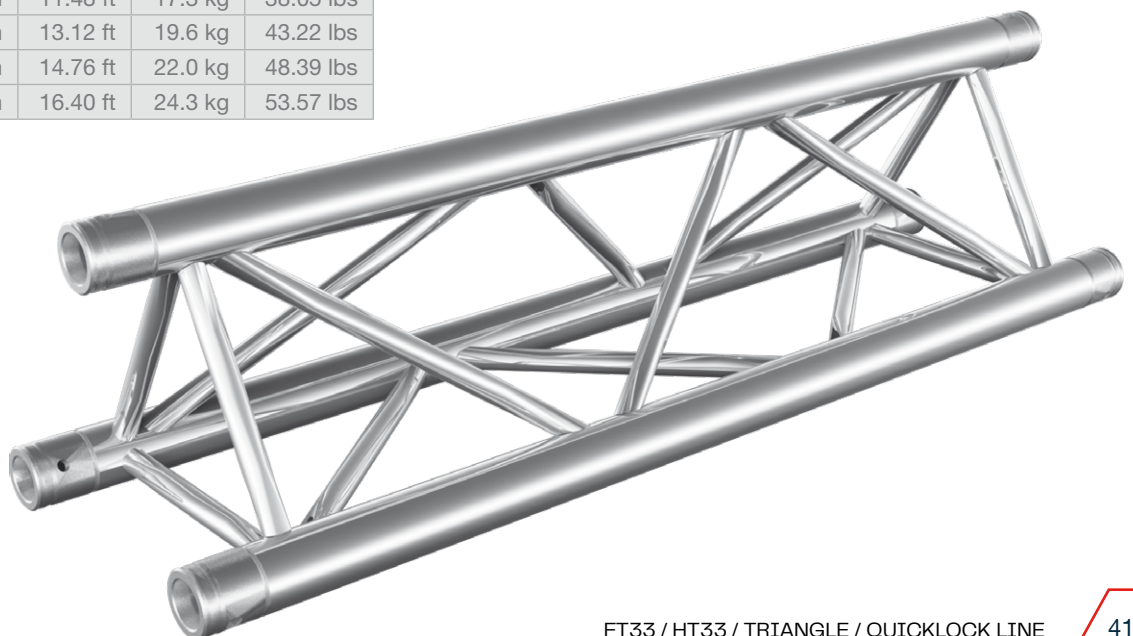

FT33 / HT33

QUICKLOCK LINE

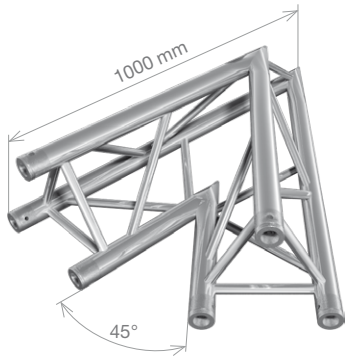

FT33-C19	HT33-C19
2-way 45° corner	
1 m (3.28 ft)	
5.7 kg (12.56 lbs)	7.2 kg (15.77 lbs)

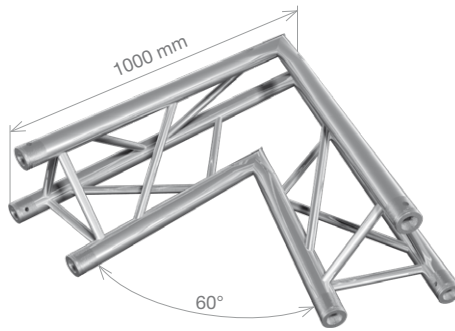

FT33-C20	HT33-C20
2-way 60° corner	
1 m (3.28 ft)	
6.1 kg (13.42 lbs)	7.7 kg (17.04 lbs)

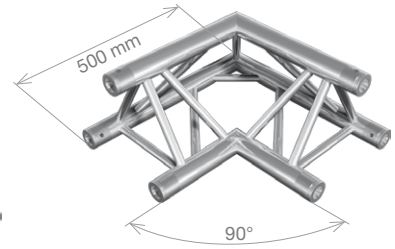

FT33-C21	HT33-C21
2-way 90° corner	
0.5 m (1.64 ft)	
3.7 kg (8.16 lbs)	4.4 kg (9.72 lbs)

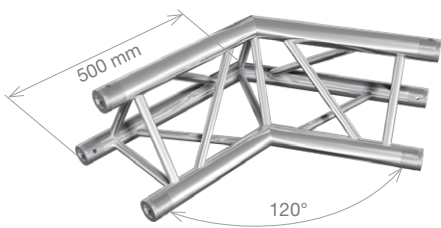

FT33-C22	HT33-C22
2-way 120° corner	
0.5 m (1.64 ft)	
4.1 kg (9.09 lbs)	4.5 kg (10.00 lbs)

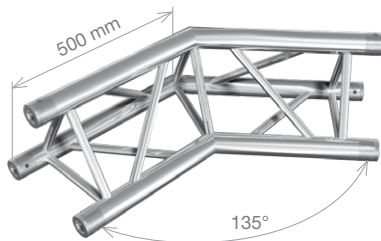

FT33-C23	HT33-C23
2-way 135° corner	
0.5 m (1.64 ft)	
4.1 kg (9.09 lbs)	4.7 kg (10.30 lbs)

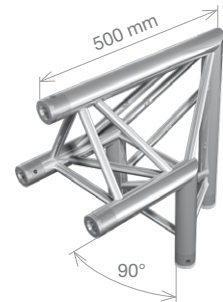

FT33-C24	HT33-C24
2-way 90° corner, apex out	
0.5 m (1.64 ft)	
3.7 kg (8.16 lbs)	4.3 kg (9.57 lbs)

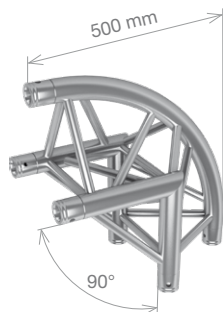

FT33-C24-R	
2-way 90° rounded corner, apex out	
0.5 m (1.64 ft)	
3.5 kg (7.79 lbs)	

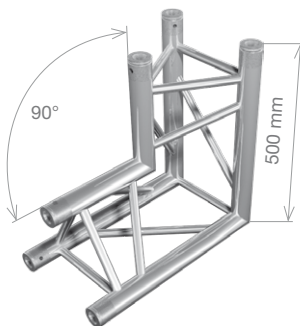

FT33-C25	HT33-C25
2-way 90° corner, apex in	
0.5 m (1.64 ft)	
3.9 kg (8.58 lbs)	4.7 kg (10.39 lbs)

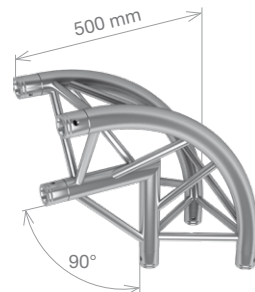

FT33-C25-R	
2-way 90° rounded corner, apex in	
0.5 m (1.64 ft)	
3.5 kg (7.79 lbs)	

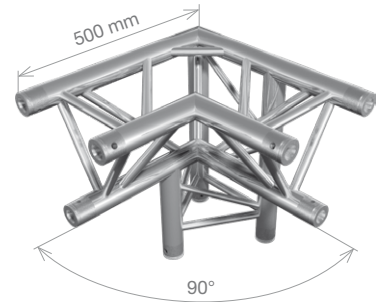
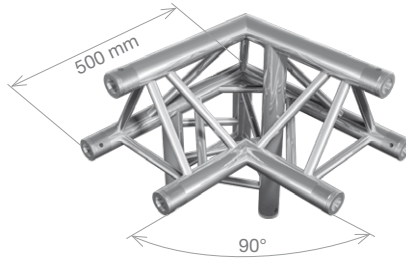
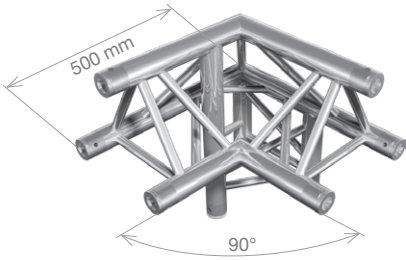

FT33-C31

HT33-C31

	3-way 90° right corner, apex up
	0.5 m (1.64 ft)
	5.3 kg (11.72 lbs)
	6.3 kg (13.90 lbs)

FT33-C32

HT33-C32

	3-way 90° left corner, apex up
	0.5 m (1.64 ft)
	5.3 kg (11.72 lbs)
	6.3 kg (13.90 lbs)

FT33-C33

HT33-C33

	3-way 90° right corner, apex down
	0.5 m (1.64 ft)
	5.6 kg (12.25 lbs)
	6.6 kg (14.60 lbs)

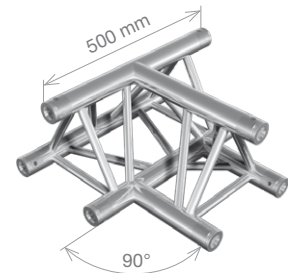
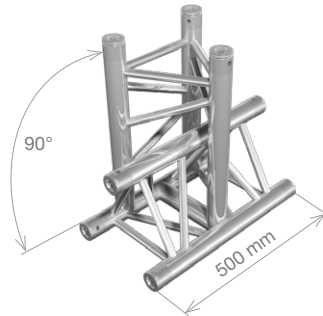
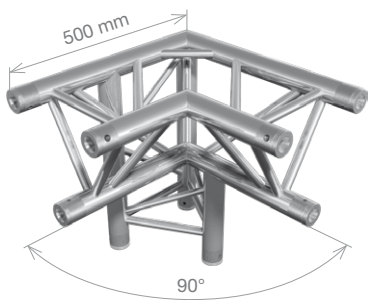

FT33-C34

HT33-C34

	3-way 90° left corner, apex down
	0.5 m (1.64 ft)
	5.6 kg (12.25 lbs)
	6.6 kg (14.60 lbs)

FT33-T35

HT33-T35

	3-way vertical T-junction, apex down
	0.5 m (1.64 ft)
	5.1 kg (11.16 lbs)
	6.0 kg (13.21 lbs)

FT33-T36

HT33-T36

	3-way horizontal T-junction
	0.5 m (1.64 ft)
	4.3 kg (9.49 lbs)
	4.9 kg (10.87 lbs)

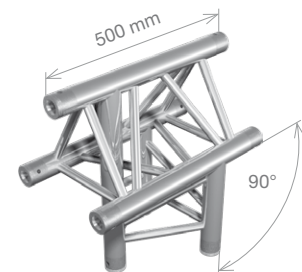
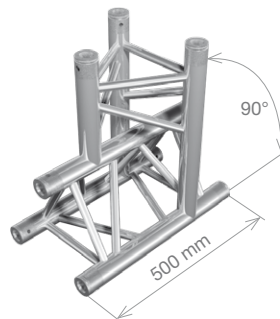
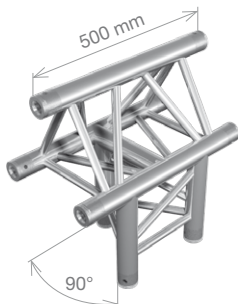

FT33-T37

HT33-T37

	3-way horizontal T-junction, apex up
	0.5 m (1.64 ft)
	4.5 kg (9.89 lbs)
	5.1 kg (11.24 lbs)

FT33-T38

HT33-T38

	3-way vertical T-junction, apex down
	0.5 m (1.64 ft)
	4.7 kg (10.25 lbs)
	5.4 kg (11.95 lbs)

FT33-T39

HT33-T39

	3-way vertical T-junction
	0.5 m (1.64 ft)
	4.5 kg (9.88 lbs)
	5.2 kg (11.41 lbs)

FT33 / HT33

QUICKLOCK LINE

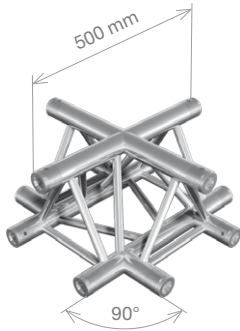

FT33-C41		HT33-C41	
	4-way cross junction 0.5 m (1.64 ft)		
	4.9 kg (10.70 lbs)		5.4 kg (12.01 lbs)



FT33-T42		HT33-T42	
	4-way T-junction, apex down 0.5 m (1.64 ft)		
	6.2 kg (13.57 lbs)		7.1 kg (15.76 lbs)

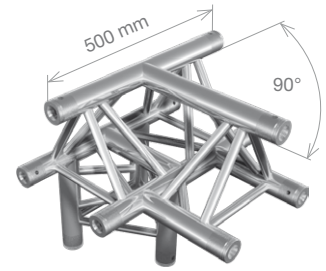

FT33-T43		HT33-T43	
	4-way T-junction, apex up 0.5 m (1.64 ft)		
	5.9 kg (13.03 lbs)		6.7 kg (14.86 lbs)

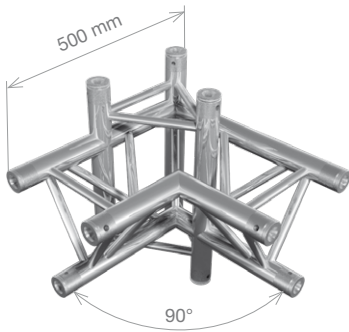

FT33-C44		HT33-C44	
	4-way 90° right corner 0.5 m (1.64 ft)		
	6.2 kg (13.57 lbs)		7.2 kg (15.93 lbs)

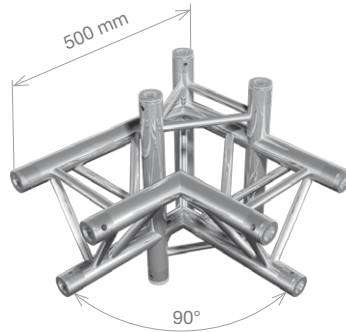

FT33-C45		HT33-C45	
	4-way 90° left corner 0.5 m (1.64 ft)		
	6.2 kg (13.57 lbs)		7.2 kg (15.93 lbs)

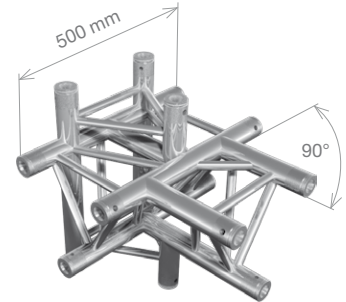

FT33-T51		HT33-T51	
	5-way T-junction, apex down 0.5 m (1.64 ft)		
	6.8 kg (14.92 lbs)		7.8 kg (17.11 lbs)

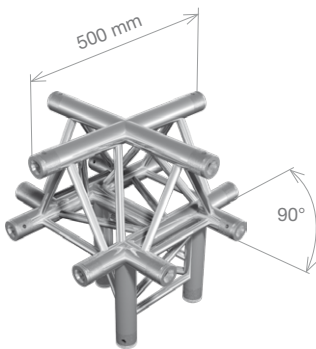

FT33-C52		HT33-C52	
	5-way cross junction, apex up 0.5 m (1.64 ft)		
	6.5 kg (14.26 lbs)		7.3 kg (16.03 lbs)

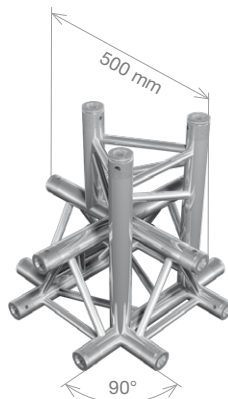

FT33-C53		HT33-C53	
	5-way cross junction, apex down 0.5 m (1.64 ft)		
	6.6 kg (14.63 lbs)		7.6 kg (16.74 lbs)

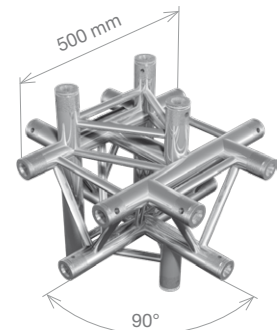

FT33-T61		HT33-T61	
	6-way T-junction 0.5 m (1.64 ft)		
	7.2 kg (15.95 lbs)		8.2 kg (18.08 lbs)



FT33-C1

Circle, apex up/down, various diameters



HT33-C1

FT33-C2

Circle, apex in, various diameters



FT33-C3

Circle, apex out, various diameters

HT33-C3

Various types of coloured powder coating are available for any type of trussing line. Available in RAL range. See samples below.

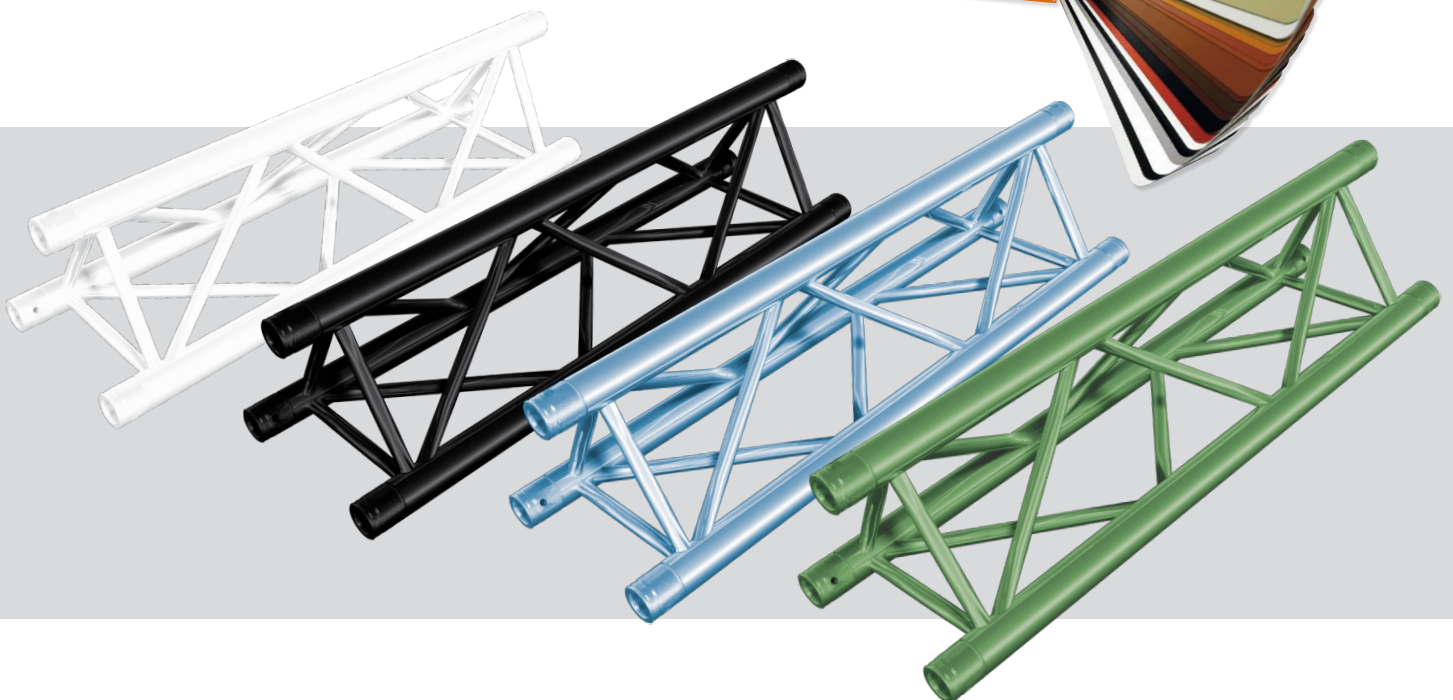

SPECIFICATIONS FT34

Tubes	50 x 2 mm (1.97 x 0.08 in)
Braces	20 x 2 mm (0.79 x 0.08 in)
Alloy	EN AW-6082 T6

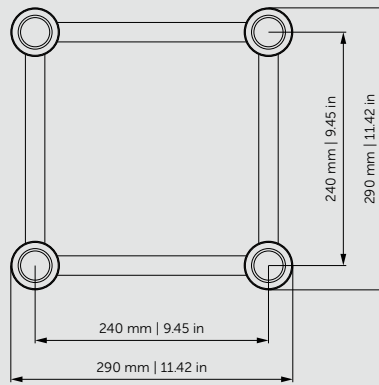

LOADING TABLES

		2 m	3 m	4 m	6 m	8 m	10 m	12 m	14 m	16 m	18 m	20 m
UDL [kg/m]		1422	946	566	250	139	86	58	39	27	16	6
Deflection [mm]		2.4	8.3	15.7	35.5	63.3	98.6	140.4	185	227.6	248.8	195.9
CPL [kg]		2261	1509	1131	750	554	432	345	275	214	148	58
Deflection [mm]		3.1	7	12.6	28.5	51.1	80.1	114.8	152.7	190	211.7	176.1
TPL [kg]		1422	1132	849	562	416	324	259	206	161	111	43
Deflection [mm]		3.3	9	16	36.2	64.6	100.7	143.2	188.6	231.8	252.9	198.1
QPL [kg]		948	755	566	375	277	216	173	138	107	74	29
Deflection [mm]		3.1	8.3	14.9	33.7	60.2	94	134	176.9	218.2	239.5	190.9
FLP [kg]		711	629	471	312	231	180	144	115	89	62	24
Deflection [mm]		3	8.9	15.9	36.1	64.3	100.2	142.6	187.8	230.9	252	197.6
		6.56 ft	9.84 ft	13.12 ft	19.69 ft	26.25 ft	32.81 ft	39.37 ft	45.93 ft	52.49 ft	59.06 ft	65.62 ft
UDL [lbs/ft]		955.54	635.68	380.33	167.99	93.40	57.79	38.97	26.21	18.14	10.75	4.03
Deflection [in]		0.09	0.33	0.62	1.40	2.49	3.88	5.53	7.28	8.96	9.80	7.71
CPL [lbs]		4984.65	3326.78	2493.43	1653.47	1221.36	952.40	760.59	606.27	471.79	326.28	127.87
Deflection [in]		0.12	0.28	0.50	1.12	2.01	3.15	4.52	6.01	7.48	8.33	6.93
TPL [lbs]		3134.97	2495.63	1871.72	1239.00	917.12	714.30	571.00	454.15	354.94	244.71	94.80
Deflection [in]		0.13	0.35	0.63	1.43	2.54	3.96	5.64	7.43	9.13	9.96	7.80
QPL [lbs]		2089.98	1664.49	1247.82	826.73	610.68	476.20	381.40	304.24	235.89	163.14	63.93
Deflection [in]		0.12	0.33	0.59	1.33	2.37	3.70	5.28	6.96	8.59	9.43	7.52
FLP [lbs]		1567.49	1386.71	1038.38	687.84	509.27	396.83	317.47	253.53	196.21	136.69	52.91
Deflection [in]		0.12	0.35	0.63	1.42	2.53	3.94	5.61	7.39	9.09	9.92	7.78

Loading tables are valid for static loads and spans with two supporting points. Spans must be supported at each end. Contact structural engineer if there are more supporting points applied or dynamic and wind loads involved.

STRAIGHT SEGMENT LENGTHS

Code	Length		Weight	
FT34-50	0.5 m	1.64 ft	3.8 kg	8.43 lbs
FT34-100	1 m	3.28 ft	6.1 kg	13.38 lbs
FT34-150	1.5 m	4.92 ft	8.4 kg	18.60 lbs
FT34-200	2 m	6.56 ft	10.8 kg	23.82 lbs
FT34-250	2.5 m	8.20 ft	13.2 kg	29.04 lbs
FT34-300	3 m	9.84 ft	15.5 kg	34.26 lbs
FT34-350	3.5 m	11.48 ft	17.9 kg	39.48 lbs
FT34-400	4 m	13.12 ft	20.3 kg	44.70 lbs
FT34-450	4.5 m	14.76 ft	22.6 kg	49.92 lbs
FT34-500	5 m	16.40 ft	25.0 kg	55.14 lbs

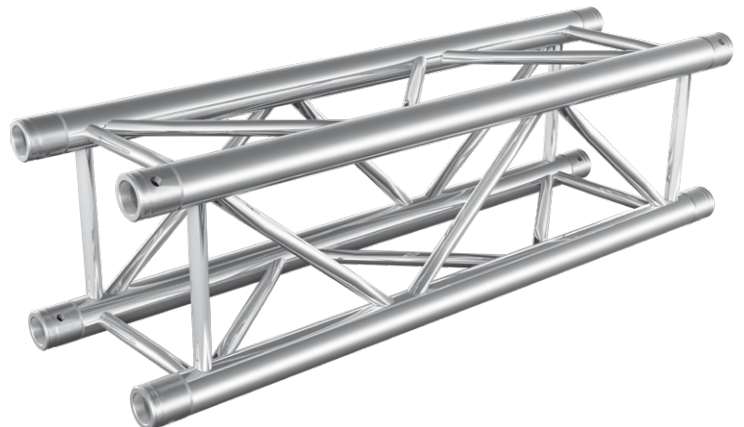

SPECIFICATIONS

Tubes	50 x 3 mm (1.97 x 0.12 in)
Braces	20 x 2 mm (0.79 x 0.08 in)
Alloy	EN AW-6082 T6

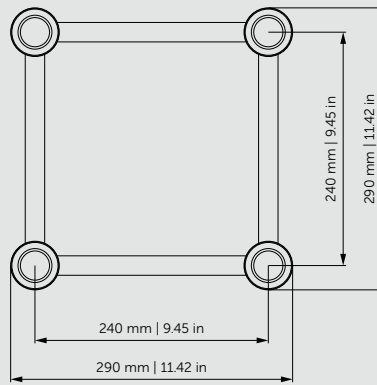

LOADING TABLES

		2 m	3 m	4 m	6 m	8 m	10 m	12 m	14 m	16 m	18 m	20 m
UDL [kg/m]		1420	944	707	359	199	125	83	58	39	25	9
Deflection [mm]		1.7	5.6	13.3	34.6	61.7	96.2	137.1	182.7	224.1	246	196.9
CPL [kg]		2847	2160	1621	1076	797	623	500	405	316	223	95
Deflection [mm]		2.7	6.8	12.2	27.8	49.8	78.1	112	150.3	186.3	208.2	174.8
TPL [kg]		1420	1417	1215	807	598	467	375	304	237	167	71
Deflection [mm]		2.3	7.6	15.6	35.3	63	98.3	139.9	186.3	228.3	250.2	199.3
QPL [kg]		947	944	810	538	398	312	250	202	158	111	47
Deflection [mm]		2.1	7.1	14.5	32.9	58.7	91.7	130.8	174.6	214.6	236.6	191.3
FLP [kg]		710	708	675	448	332	260	208	169	132	93	39
Deflection [mm]		2	6.9	15.5	35.2	62.7	97.8	139.3	185.5	227.3	249.3	198.8
		6.56 ft	9.84 ft	13.12 ft	19.69 ft	26.25 ft	32.81 ft	39.37 ft	45.93 ft	52.49 ft	59.06 ft	65.62 ft
UDL [lbs/ft]		954.20	634.34	475.08	241.24	133.72	84.00	55.77	38.97	26.21	16.80	6.05
Deflection [in]		0.07	0.22	0.52	1.36	2.43	3.79	5.40	7.19	8.82	9.69	7.75
CPL [lbs]		6276.56	4761.98	3573.69	2372.17	1757.08	1373.48	1102.31	892.87	696.66	491.63	209.44
Deflection [in]		0.11	0.27	0.48	1.09	1.96	3.07	4.41	5.92	7.33	8.20	6.88
TPL [lbs]		3130.56	3123.95	2678.62	1779.13	1318.36	1029.56	826.73	670.21	522.50	368.17	156.53
Deflection [in]		0.09	0.30	0.61	1.39	2.48	3.87	5.51	7.33	8.99	9.85	7.85
QPL [lbs]		2087.78	2081.16	1785.74	1186.09	877.44	687.84	551.16	445.33	348.33	244.71	103.62
Deflection [in]		0.08	0.28	0.57	1.30	2.31	3.61	5.15	6.87	8.45	9.31	7.53
FLP [lbs]		1565.28	1560.87	1488.12	987.67	731.93	573.20	458.56	372.58	291.01	205.03	85.98
Deflection [in]		0.08	0.27	0.61	1.39	2.47	3.85	5.48	7.30	8.95	9.81	7.83

Loading tables are valid for static loads and spans with two supporting points. Spans must be supported at each end. Contact structural engineer if there are more supporting points applied or dynamic and wind loads involved.

STRAIGHT SEGMENT LENGTHS

Code	Length		Weight	
	m	ft	kg	lbs
HT34-50	0.5 m	1.64 ft	4.4 kg	9.63 lbs
HT34-100	1 m	3.28 ft	7.4 kg	16.25 lbs
HT34-150	1.5 m	4.92 ft	10.5 kg	23.15 lbs
HT34-200	2 m	6.56 ft	13.6 kg	30.04 lbs
HT34-250	2.5 m	8.20 ft	16.8 kg	36.94 lbs
HT34-300	3 m	9.84 ft	19.9 kg	43.84 lbs
HT34-350	3.5 m	11.48 ft	23.0 kg	50.73 lbs
HT34-400	4 m	13.12 ft	26.1 kg	57.63 lbs
HT34-450	4.5 m	14.76 ft	29.3 kg	64.52 lbs
HT34-500	5 m	16.40 ft	32.4 kg	71.42 lbs

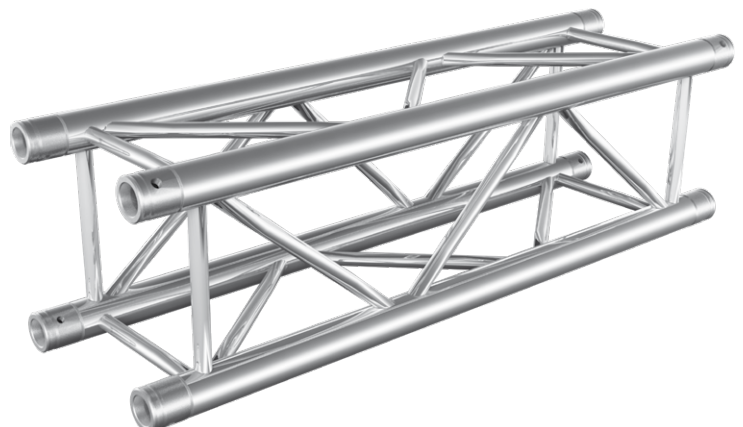

FT34 / HT34

QUICKLOCK LINE

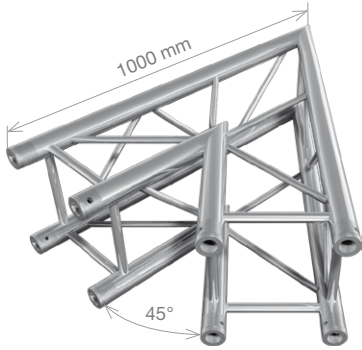

FT34-C19	HT34-C19
2-way 45° corner	
1 m (3.28 ft)	
7.83 kg (17.25 lbs)	9.77 kg (21.54 lbs)

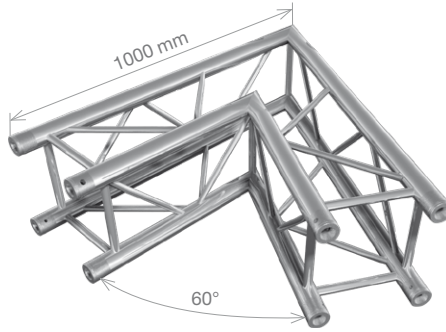

FT34-C20	HT34-C20
2-way 60° corner	
1 m (3.28 ft)	
8.71 kg (19.21 lbs)	10.90 kg (24.04 lbs)

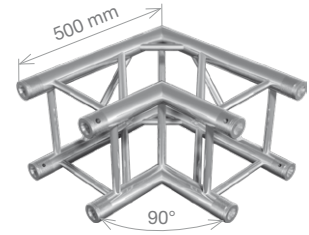

FT34-C21	HT34-C21
2-way 90° corner	
0.5 m (1.64 ft)	
4.87 kg (10.74 lbs)	5.81 kg (12.81 lbs)

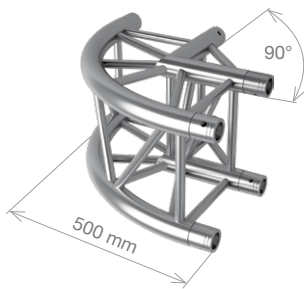

FT34-C21-R	HT34-C21-R
2-way 90° rounded corner	
0.5 m (1.64 ft)	
4.77 kg (10.52 lbs)	

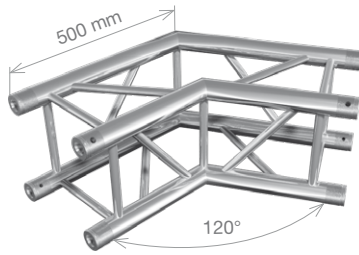

FT34-C22	HT34-C22
2-way 120° corner	
0.5 m (1.64 ft)	
5.28 kg (11.64 lbs)	5.69 kg (12.54 lbs)

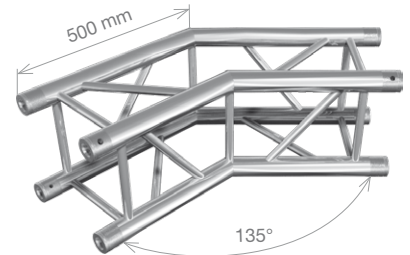

FT34-C23	HT34-C23
2-way 135° corner	
0.5 m (1.64 ft)	
5.41 kg (11.92 lbs)	5.87 kg (12.95 lbs)

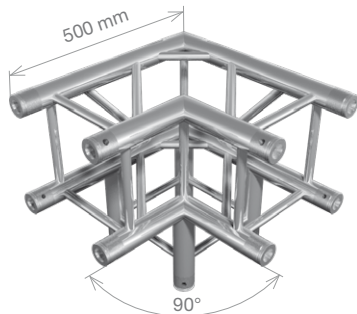

FT34-C30	HT34-C30
3-way 90° corner	
0.5 m (1.64 ft)	
6.41 kg (14.12 lbs)	7.57 kg (16.69 lbs)

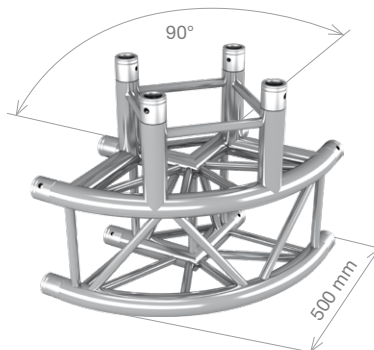

FT34-C30-R	HT34-C30-R
3-way 90° rounded corner	
0.5 m (1.64 ft)	
6.63 kg (14.62 lbs)	

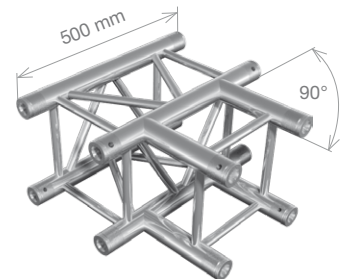

FT34-T35	HT34-T35
3-way T-junction	
0.5 m (1.64 ft)	
5.36 kg (11.82 lbs)	6.13 kg (13.51 lbs)

CORNERS

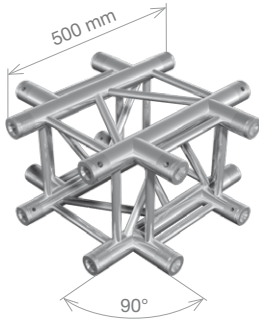

FT34-C41

HT34-C41

	4-way cross junction
	0.5 m (1.64 ft)
	6.21 kg (13.69 lbs)
	6.88 kg (15.17 lbs)

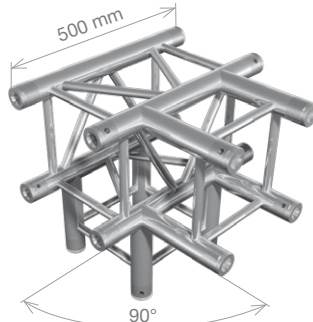

FT34-T42

HT34-T42

	4-way T junction
	0.5 m (1.64 ft)
	6.90 kg (15.20 lbs)
	7.89 kg (17.39 lbs)

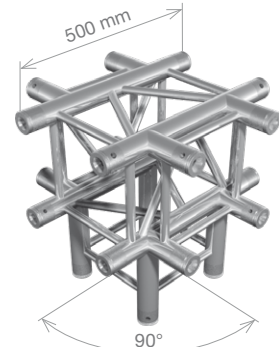

FT34-C55

HT34-C55

	5-way T-junction
	0.5 m (1.64 ft)
	7.74 kg (17.07 lbs)
	8.64 kg (19.05 lbs)



FT34-C60

HT34-C60

	6-way T-junction
	0.5 m (1.64 ft)
	8.59 kg (18.94 lbs)
	9.39 kg (20.71 lbs)

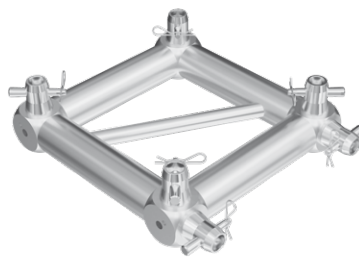

FT34-32F

HT34-32F

	Frame FT34+FT32 / Frame HT34+HT32
	0.5 m (1.64 ft)
	2.87 kg (6.32 lbs)
	3.18 kg (7.02 lbs)

Includes connection sets for two ways.



FT34-MCB

HT34-MCB

	Multi connection box
	0.29 x 0.29 m (0.95 x 0.95 ft)
	9.31 kg (20.53 lbs)
	10.08 kg (22.23 lbs)

Includes connection sets for two ways.

CIRCLES



FT34-C

HT34-C

	Circle, various diameters
--	------------------------------

SPECIFICATIONS

Tubes	50 x 2 mm (1.97 x 0.08 in)
Braces	25 x 3 mm (0.98 x 0.12 in)
Alloy	EN AW-6082 T6

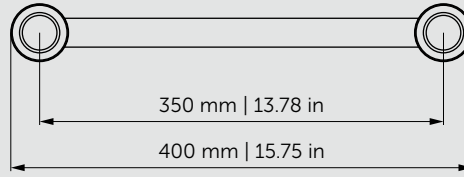

LOADING TABLES

		2 m	4 m	6 m	8 m	10 m	12 m	14 m	16 m
UDL [kg/m]		756	243	109	61	39	27	19	14
Deflection [mm]		1.2	6.4	14.7	26.7	42.7	63	87.8	115.3
CPL [kg]		756	486	327	245	195	161	135	113
Deflection [mm]		1	5.1	11.8	21.6	34.8	51.8	72.9	96.7
		6.56 ft	13.12 ft	19.68 ft	26.24 ft	32.81 ft	39.37 ft	45.93 ft	52.49 ft
UDL [lbs/ft]		508.1	163.3	73.3	41	26.2	18.1	12.8	9.4
Deflection [in]		0.05	0.3	0.6	1.1	1.7	2.5	3.5	4.5
CPL [lbs]		1667	1071.6	721	540.2	430	355	297.7	249.2
Deflection [in]		0.04	0.2	0.5	0.9	1.4	2	2.9	3.8

Loading tables are valid for static loads and spans with two supporting points.

Spans must be supported at each end.

Contact structural engineer if there are more supporting points applied or dynamic and wind loads involved.

The listed loads are verified for simply supported beam.

The truss needs to be secured against horizontal movement every 1 m for the loading tables to be valid.

STRAIGHT SEGMENT LENGTHS

Code	Length		Weight	
FT42-50	0.5 m	1.64 ft	1.95 kg	4.29 lbs
FT42-100	1 m	3.28 ft	3.20 kg	7.05 lbs
FT42-150	1.5 m	4.92 ft	4.34 kg	9.58 lbs
FT42-200	2 m	6.56 ft	5.45 kg	12.02 lbs
FT42-250	2.5 m	8.20 ft	6.58 kg	14.52 lbs
FT42-300	3 m	9.84 ft	7.81 kg	17.21 lbs
FT42-350	3.5 m	11.48 ft	8.92 kg	19.67 lbs
FT42-400	4 m	13.12 ft	10.09 kg	22.25 lbs
FT42-450	4.5 m	14.76 ft	11.17 kg	24.63 lbs
FT42-500	5 m	16.40 ft	12.39 kg	27.31 lbs

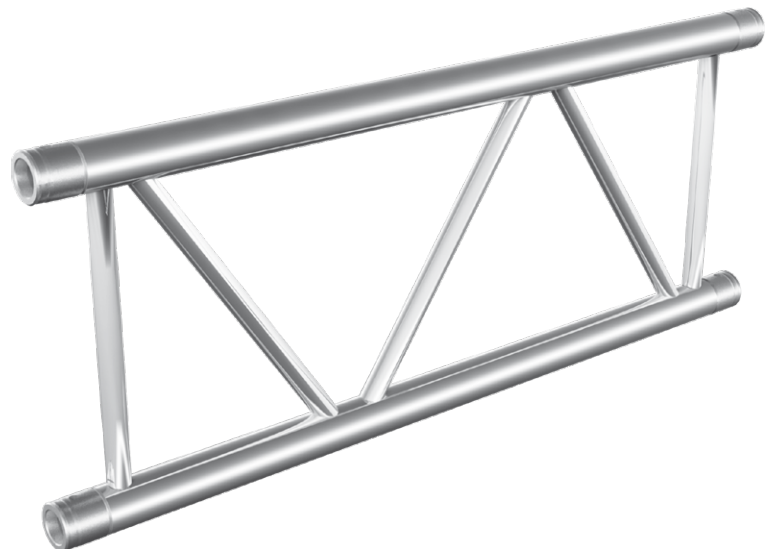

SPECIFICATIONS

Tubes	50 x 3 mm (1.97 x 0.12 in)
Braces	25 x 3 mm (0.98 x 0.12 in)
Alloy	EN AW-6082 T6

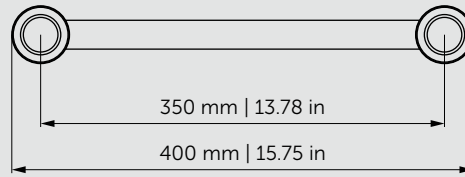

LOADING TABLES

		2 m	4 m	6 m	8 m	10 m	12 m	14 m	16 m
UDL [kg/m]		1042	332	153	87	57	40	29	21
Deflection [mm]		1.1	5.9	14	25.7	42.1	63.5	87.9	115.2
CPL [kg]		1042	664	459	349	286	243	204	172
Deflection [mm]		0.9	4.7	11.3	20.8	34.3	52	72.5	95.9
		6.56 ft	13.12 ft	19.68 ft	26.24 ft	32.81 ft	39.37 ft	45.93 ft	52.49 ft
UDL [lbs/ft]		700.3	223.1	102.8	58.5	38.3	26.9	19.5	14.1
Deflection [in]		0.04	0.2	0.6	1	1.7	2.5	3.5	4.5
CPL [lbs]		2297.6	1464.1	1012.1	769.5	630.6	535.8	449.8	379.3
Deflection [in]		0.04	0.2	0.4	0.8	1.4	2	2.9	3.8

Loading tables are valid for static loads and spans with two supporting points.

Spans must be supported at each end.

Contact structural engineer if there are more supporting points applied or dynamic and wind loads involved.

The listed loads are verified for simply supported beam.

The truss needs to be secured against horizontal movement every 1 m for the loading tables to be valid.

STRAIGHT SEGMENT LENGTHS HT42

Code	Length		Weight	
HT42-50	0.5 m	1.64 ft	2.22 kg	4.89 lbs
HT42-100	1 m	3.28 ft	3.85 kg	8.49 lbs
HT42-150	1.5 m	4.92 ft	5.37 kg	11.85 lbs
HT42-200	2 m	6.56 ft	6.86 kg	15.13 lbs
HT42-250	2.5 m	8.20 ft	8.37 kg	18.47 lbs
HT42-300	3 m	9.84 ft	9.98 kg	22.00 lbs
HT42-350	3.5 m	11.48 ft	11.47 kg	25.29 lbs
HT42-400	4 m	13.12 ft	13.02 kg	28.71 lbs
HT42-450	4.5 m	14.76 ft	14.49 kg	31.94 lbs
HT42-500	5 m	16.40 ft	16.08 kg	35.45 lbs

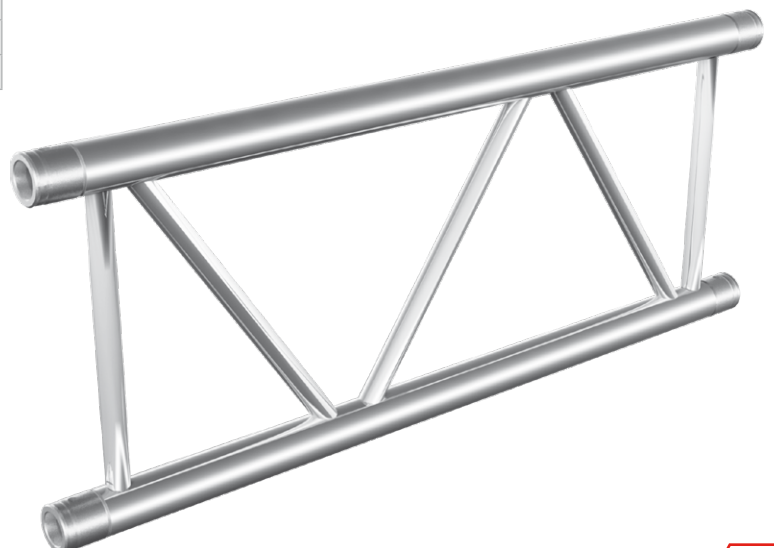

FT42 / HT42

QUICKLOCK LINE



FT42-C19V	HT42-C19V
2-way 45° vertical corner	
0.5 m (1.64 ft)	
3.22 kg (7.11 lbs)	3.88 kg (8.55 lbs)

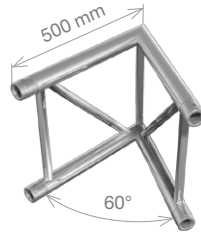

FT42-C20V	HT42-C20V
2-way 60° vertical corner	
0.5 m (1.64 ft)	
3.22 kg (7.11 lbs)	3.88 kg (8.55 lbs)

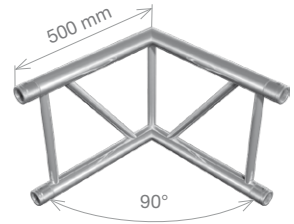

FT42-C21V	HT42-C21V
2-way 90° vertical corner	
0.5 m (1.64 ft)	
3.22 kg (7.11 lbs)	3.88 kg (8.55 lbs)

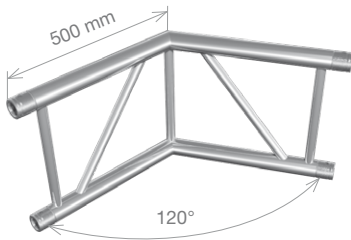

FT42-C22V	HT42-C22V
2-way 120° vertical corner	
0.5 m (1.64 ft)	
3.22 kg (7.11 lbs)	3.88 kg (8.55 lbs)

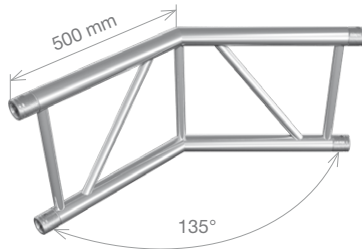

FT42-C23V	HT42-C23V
2-way 135° vertical corner	
0.5 m (1.64 ft)	
3.22 kg (7.11 lbs)	3.88 kg (8.55 lbs)

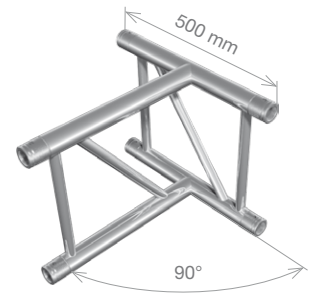

FT42-T35V	HT42-T35V
3-way vertical T-junction	
0.5 m (1.64 ft)	
3.41 kg (7.52 lbs)	4.26 kg (9.40 lbs)

CIRCLES

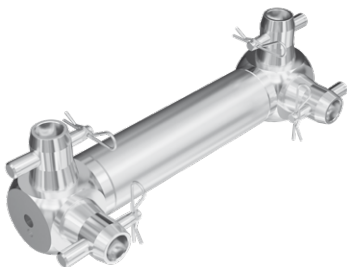

FT42-31AD	HT42-31AD
FT42-FT31 Adapter / HT42HT31 Adapter	
0.4 m (1.31 ft)	
0.77 kg (1.70 lbs)	0.88 kg (1.93 lbs)

Includes connection sets for two ways.

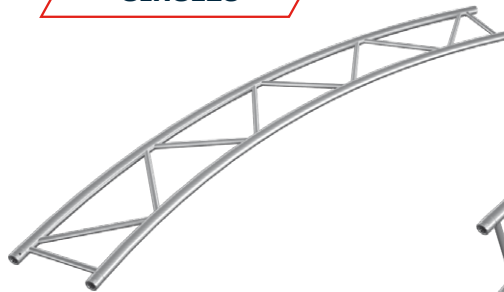

FT42-CH	HT42-CH
Horizontal circle, various diameters	

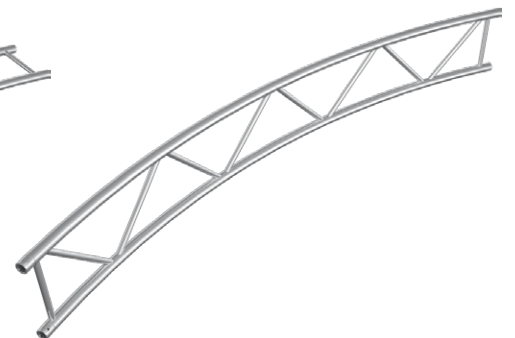

FT42-CV	HT42-CV
Vertical circle, various diameters	

The unique TAFtool software was created to help our clients easily construct their own stands or custom designs from TAF's aluminium trusses.

TAFtool provides users with a realistic 3D work space to build their structures.

The library of trussing systems available to users includes standard components provided in the chosen system, which allows for a true representation of the real dimensions of each trussing segment. It is possible to zoom in/out to view details of individual segments or parts of the structure, or to have an overall view of the design. You can also rotate the point of view to see how the structure will look from various angles.

Unfinished projects can be easily saved, so you can work on them later. After finishing the design, you can export your project to a PDF file that shows a list of all components utilized in its construction, along with an overall view of the structure and its real dimensions.

Download the TAFtool software today at www.taftool.com. Once downloaded, you can immediately open it and start working on your own designs. You can also watch videos that show various TAFtool applications on our YouTube channel at youtube.com/@Trussaluminiumfactory and www.taftool.com/tutorials.

There is no tool like TAFtool.

Download it today and start building your own custom structures!

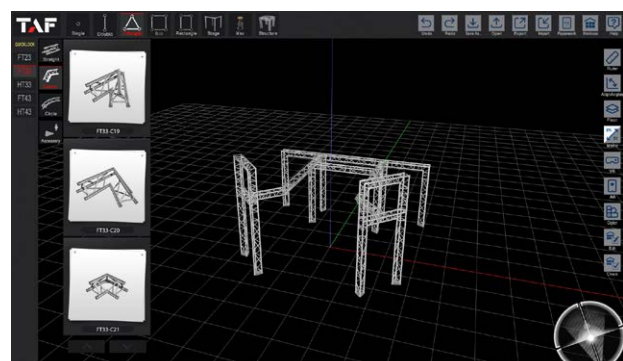
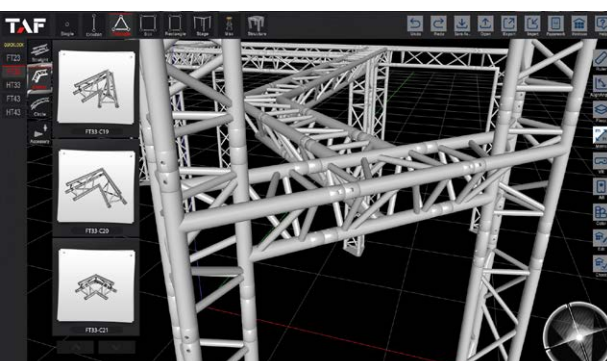
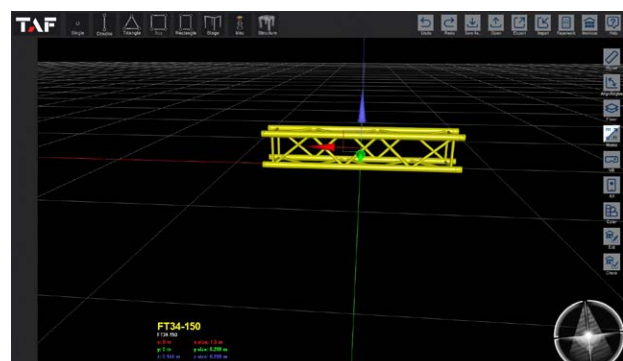
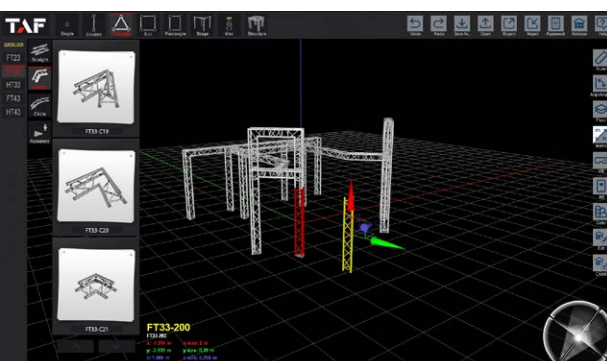
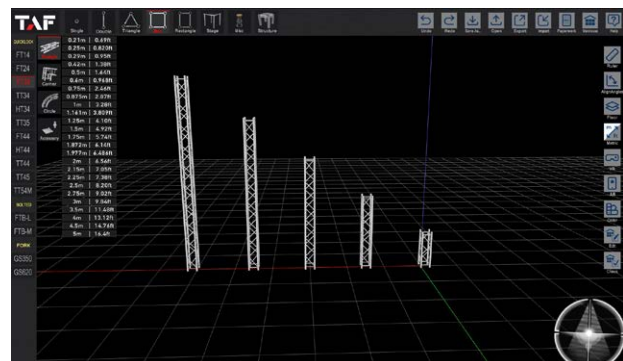
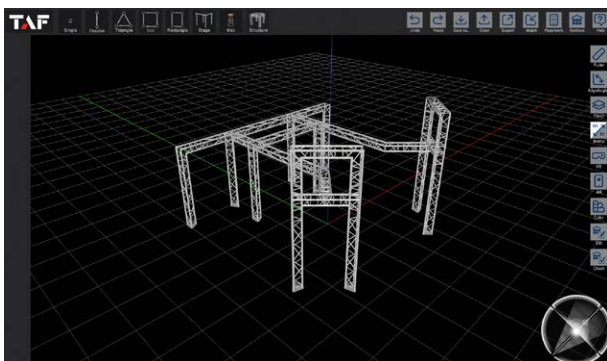
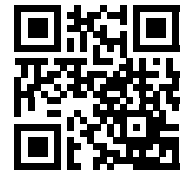

SPECIFICATIONS

Tubes	50 x 2 mm (1.97 x 0.08 in)
Braces	25 x 3 mm (0.98 x 0.12 in)
Alloy	EN AW-6082 T6

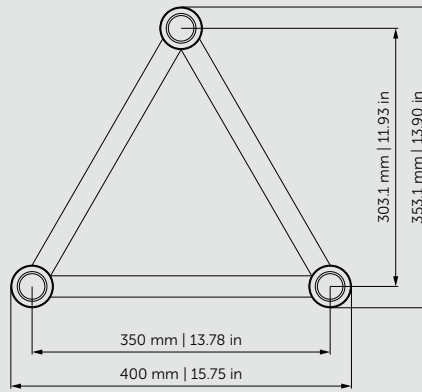

LOADING TABLES

		2 m	4 m	6 m	8 m	10 m	12 m	14 m	16 m
UDL [kg/m]		779	272	124	70	45	31	21	15
Deflection [mm]		1.3	7.2	16.9	31.3	50.9	75.6	100.8	133.3
CPL [kg]		779	544	371	282	225	184	144	121
Deflection [mm]		1	5.8	13.6	25.5	41.8	62.8	84.9	116.1
		6.56 ft	13.12 ft	19.68 ft	26.24 ft	32.81 ft	39.37 ft	45.93 ft	52.49 ft
UDL [lbs/ft]		523.5	182.8	83.3	47	30.2	20.8	14.1	10.1
Deflection [in]		0.1	0.3	0.7	1.2	2	3	4	5.2
CPL [lbs]		1717.7	1199.5	818.1	621.8	496.1	405.7	317.5	266.8
Deflection [in]		0.04	0.2	0.5	1	1.6	2.5	3.3	4.6

Loading tables are valid for static loads and spans with two supporting points. Spans must be supported at each end.

Contact structural engineer if there are more supporting points applied or dynamic and wind loads involved.

STRAIGHT SEGMENT LENGTHS

Code	Length		Weight	
FT43-50	0.5 m	1.64 ft	3.75 kg	8.27 lbs
FT43-100	1 m	3.28 ft	6.28 kg	13.84 lbs
FT43-150	1.5 m	4.92 ft	8.48 kg	18.69 lbs
FT43-200	2 m	6.56 ft	10.57 kg	23.31 lbs
FT43-250	2.5 m	8.20 ft	12.74 kg	28.08 lbs
FT43-300	3 m	9.84 ft	15.18 kg	33.47 lbs
FT43-350	3.5 m	11.48 ft	17.29 kg	38.11 lbs
FT43-400	4 m	13.12 ft	19.57 kg	43.15 lbs
FT43-450	4.5 m	14.76 ft	21.59 kg	47.59 lbs
FT43-500	5 m	16.40 ft	24.00 kg	52.91 lbs

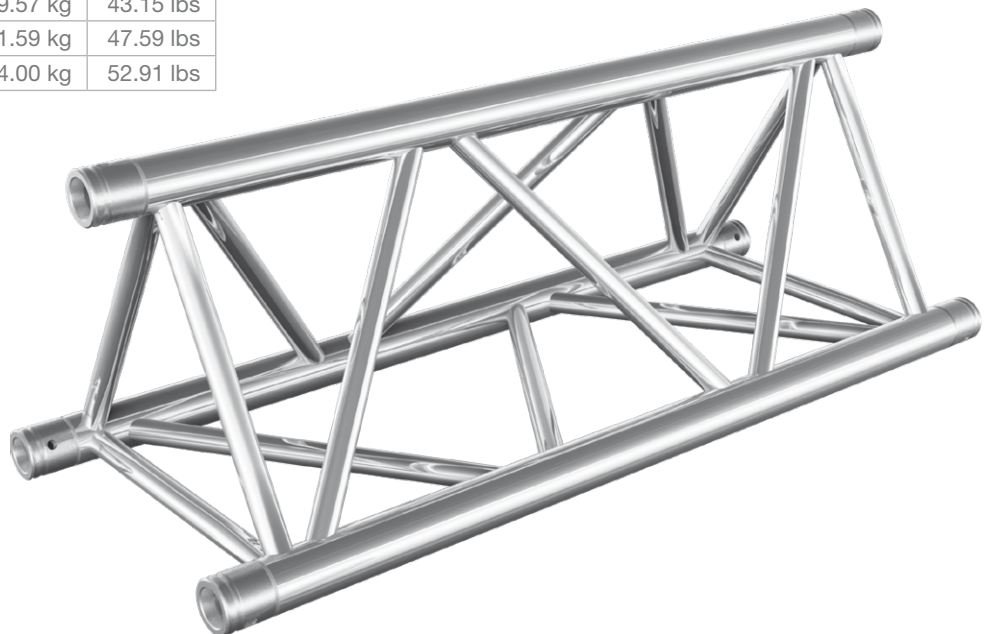

SPECIFICATIONS

Tubes	50 x 3 mm (1.97 x 0.12 in)
Braces	25 x 3 mm (0.98 x 0.12 in)
Alloy	EN AW-6082 T6

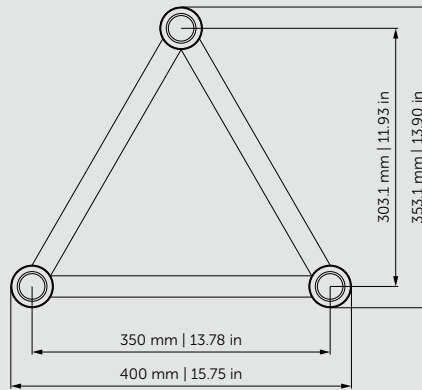

LOADING TABLES

		2 m	4 m	6 m	8 m	10 m	12 m	14 m	16 m
UDL [kg/m]		1412	457	212	119	75	51	34	25
Deflection [mm]		1.6	8.1	19.4	35.3	56.2	81.9	108.8	140.9
CPL [kg]		1412	913	636	475	375	304	241	207
Deflection [mm]		1.2	6.5	15.7	28.6	45.9	67.5	90.7	123.7
		6.56 ft	13.12 ft	19.68 ft	26.24 ft	32.81 ft	39.37 ft	45.93 ft	52.49 ft
UDL [lbs/ft]		948.9	307.1	142.5	80	50.4	34.3	22.8	16.8
Deflection [in]		0.1	0.3	0.8	1.4	2.2	3.2	4.3	5.5
CPL [lbs]		3113.5	2013.2	1402.4	1047.4	826.9	670.3	531.4	456.4
Deflection [in]		0.05	0.3	0.6	1.1	1.8	2.7	3.6	4.9

Loading tables are valid for static loads and spans with two supporting points.

Spans must be supported at each end.

Contact structural engineer if there are more supporting points applied or dynamic and wind loads involved.

STRAIGHT SEGMENT LENGTHS

Code	Length		Weight	
	m	ft	kg	lbs
HT43-50	0.5 m	1.64 ft	4.16 kg	9.17 lbs
HT43-100	1 m	3.28 ft	7.25 kg	15.99 lbs
HT43-150	1.5 m	4.92 ft	10.03 kg	22.10 lbs
HT43-200	2 m	6.56 ft	12.69 kg	27.98 lbs
HT43-250	2.5 m	8.20 ft	15.43 kg	34.01 lbs
HT43-300	3 m	9.84 ft	18.44 kg	40.65 lbs
HT43-350	3.5 m	11.48 ft	21.11 kg	46.55 lbs
HT43-400	4 m	13.12 ft	23.97 kg	52.84 lbs
HT43-450	4.5 m	14.76 ft	26.56 kg	58.55 lbs
HT43-500	5 m	16.40 ft	29.54 kg	65.12 lbs

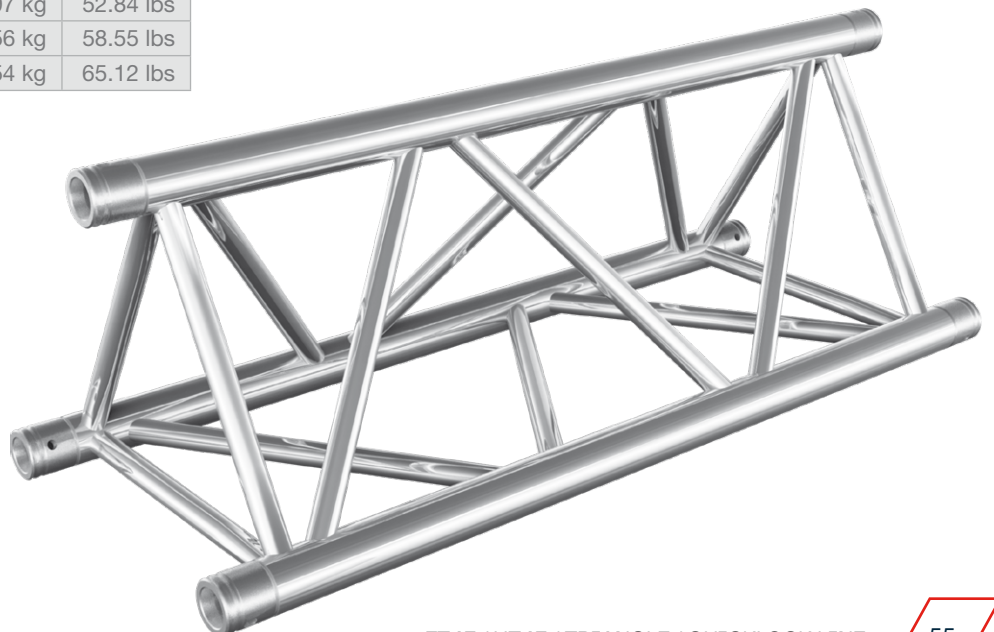

FT43 / HT43

QUICKLOCK LINE

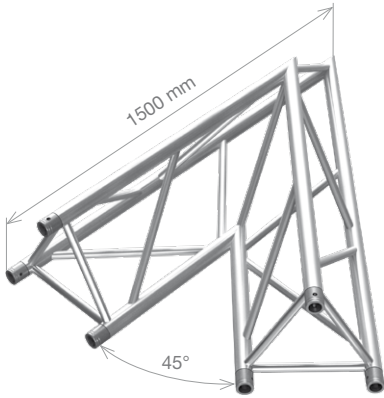

FT43-C19	HT43-C19
2-way 45° corner 1.5 m (4.92 ft)	
10.34 kg (22.80 lbs)	12.64 kg (27.85 lbs)

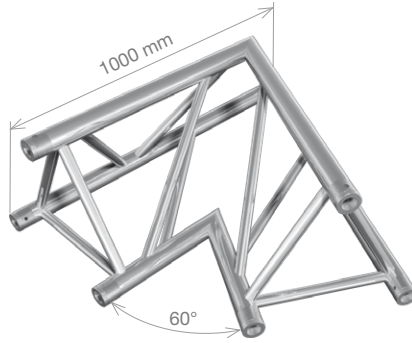

FT43-C20	HT43-C20
2-way 60° corner 1.0 m (3.28 ft)	
7.46 kg (16.45 lbs)	8.89 kg (19.59 lbs)

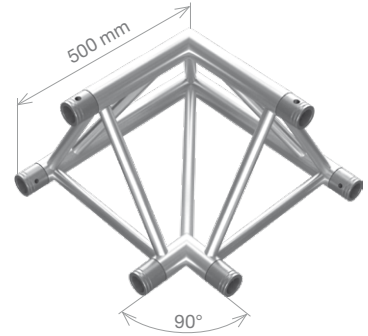

FT43-C21	HT43-C21
2-way 90° corner 0.5 m (1.64 ft)	
4.34 kg (9.57 lbs)	4.84 kg (10.67 lbs)

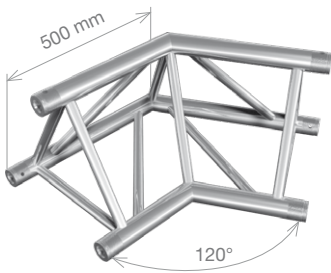

FT43-C22	HT43-C22
2-way 120° corner 0.5 m (1.64 ft)	
5.05 kg (11.13 lbs)	5.27 kg (11.61 lbs)

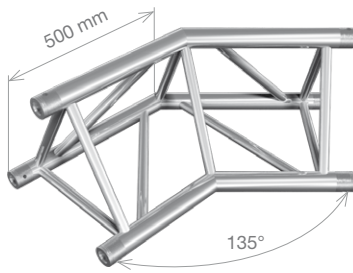

FT43-C23	HT43-C23
2-way 135° corner 0.5 m (1.64 ft)	
5.18 kg (11.42 lbs)	5.65 kg (12.46 lbs)

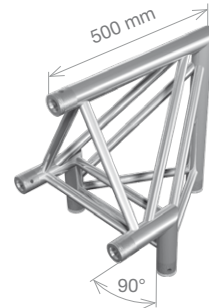

FT43-C24	HT43-C24
2-way 90° corner, apex out 0.5 m (1.64 ft)	
3.96 kg (8.72 lbs)	4.47 kg (9.85 lbs)

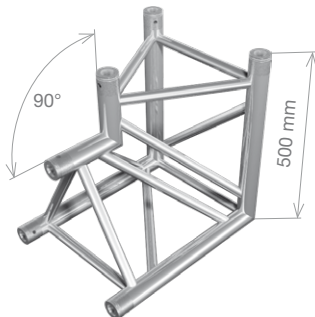

FT43-C25	HT43-C25
2-way 90° corner, apex in 0.5 m (1.64 ft)	
4.96 kg (10.93 lbs)	5.70 kg (12.57 lbs)

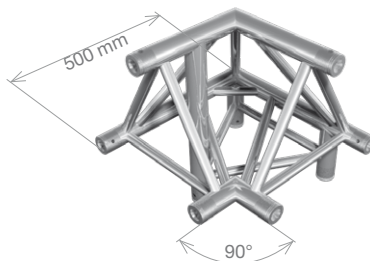

FT43-C31	HT43-C31
3-way 90° right corner, apex up 0.5 m (1.64 ft)	
5.91 kg (13.04 lbs)	6.63 kg (14.61 lbs)

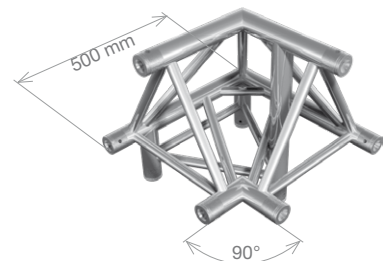

FT43-C32	HT43-C32
3-way 90° left corner, apex up 0.5 m (1.64 ft)	
5.91 kg (13.04 lbs)	6.63 kg (14.61 lbs)

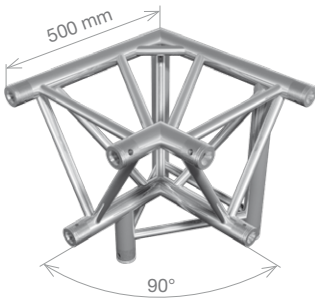

FT43-C33		HT43-C33	
	3-way 90° right corner, apex down		
	0.5 m (1.64 ft)		
	6.37 kg (14.05 lbs)	7.21 kg (15.88 lbs)	

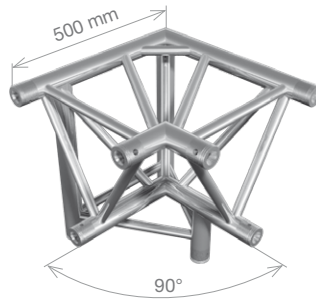

FT43-C34		HT43-C34	
	3-way 90° left corner, apex down		
	0.5 m (1.64 ft)		
	6.37 kg (14.05 lbs)	7.21 kg (15.88 lbs)	

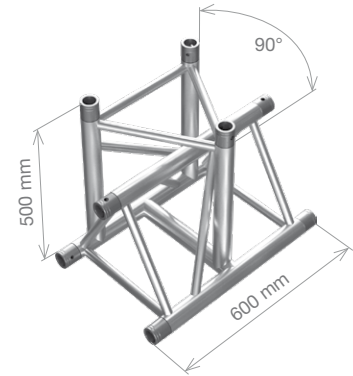

FT43-T35		HT43-T35	
	3-way horizontal T-junction, apex down		
	0.6 x 0.5 m (1.97 x 1.64 ft)		
	6.33 kg (13.96 lbs)	7.41 kg (16.34 lbs)	

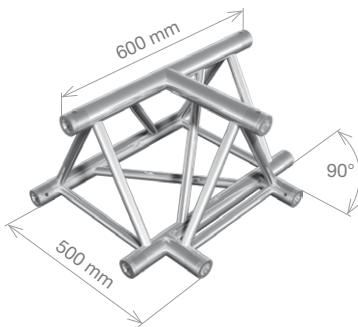

FT43-T36		HT43-T36	
	3-way horizontal T-junction		
	0.6 x 0.5 m (1.97 x 1.64 ft)		
	5.35 kg (11.79 lbs)	5.98 kg (13.18 lbs)	

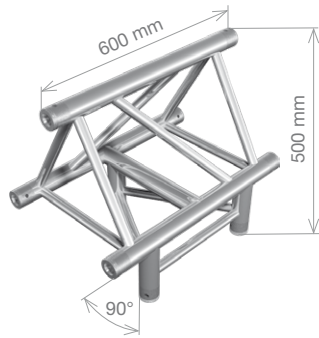

FT43-T37		HT43-T37	
	3-way horizontal T-junction, apex up		
	0.6 x 0.5 m (1.97 x 1.64 ft)		
	5.37 kg (11.84 lbs)	6.11 kg (13.46 lbs)	

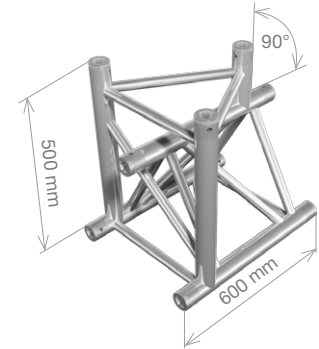

FT43-T38		HT43-T38	
	3-way vertical T-junction		
	0.6 x 0.5 m (1.97 x 1.64 ft)		
	6.03 kg (13.30 lbs)	6.88 kg (15.17 lbs)	

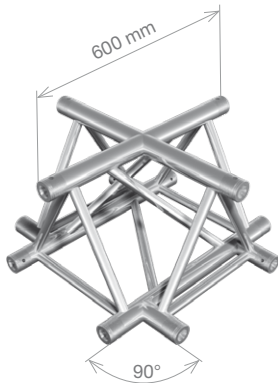

FT43-C41		HT43-C41	
	4-way cross junction		
	0.6 m (1.97 ft)		
	6.7 kg (14.77 lbs)	7.44 kg (16.39 lbs)	

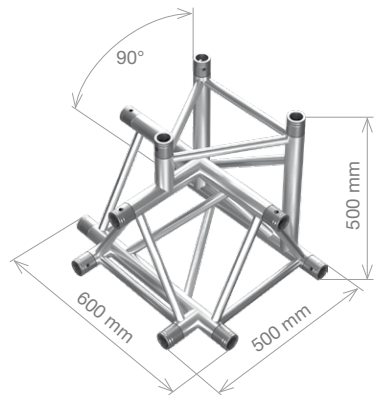

FT43-T42		HT43-T42	
	4-way T-junction, apex down		
	0.6 x 0.5 x 0.5 m (1.97 x 1.64 x 1.64 ft)		
	7.38 kg (16.29 lbs)	8.45 kg (18.67 lbs)	

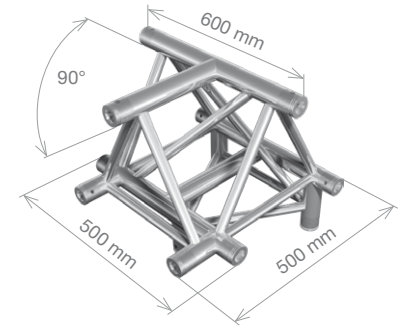

FT43-T43		HT43-T43	
	4-way T-junction, apex up		
	0.6 x 0.5 x 0.5 m (1.97 x 1.64 x 1.64 ft)		
	6.72 kg (14.82 lbs)	7.56 kg (16.68 lbs)	

FT43 / HT43

QUICKLOCK LINE

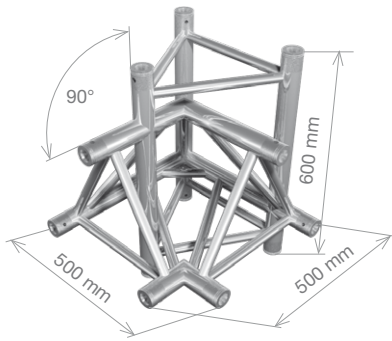

FT43-C44		HT43-C44	
	4-way 90° right corner		
	0.5 m (1.64 ft)		
	8.05 kg (17.75 lbs)	9.04 kg (19.92 lbs)	

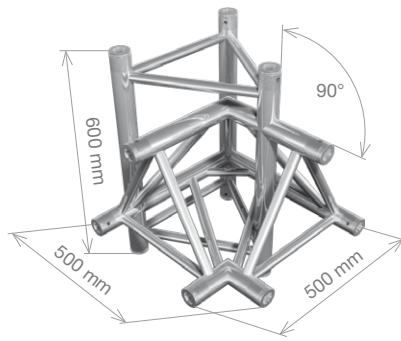

FT43-C45		HT43-C45	
	4-way 90° left corner		
	0.5 m (1.64 ft)		
	8.05 kg (17.75 lbs)	9.04 kg (19.92 lbs)	

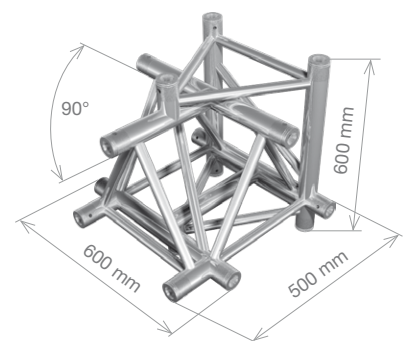

FT43-T51		HT43-T51	
	5-way T-junction, apex down		
	0.6 x 0.6 x 0.5 m (1.97 x 1.97 x 1.64 ft)		
	8.33 kg (18.35 lbs)	9.30 kg (20.49 lbs)	

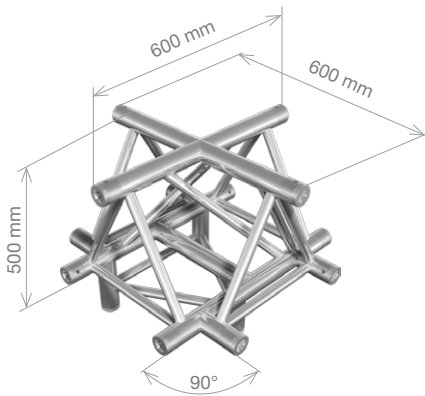

FT43-C52		HT43-C52	
	5-way cross junction, apex up		
	0.6 x 0.6 x 0.5 m (1.97 x 1.97 x 1.64 ft)		
	7.92 kg (17.47 lbs)	8.64 kg (19.05 lbs)	

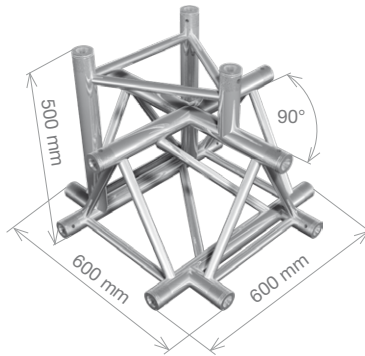

FT43-C53		HT43-C53	
	5-way cross junction, apex down		
	0.6 x 0.6 x 0.5 m (1.97 x 1.97 x 1.64 ft)		
	8.74 kg (19.26 lbs)	9.80 kg (21.60 lbs)	

CIRCLES

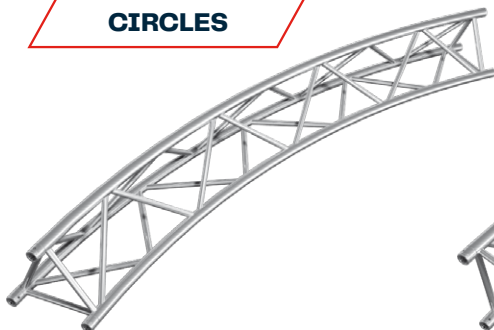

FT43-C1		HT43-C1	
	Circle, apex up/down, various diameters		

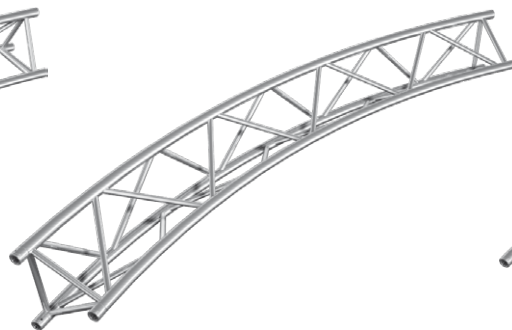

FT43-C2		HT43-C2	
	Circle, apex in, various diameters		

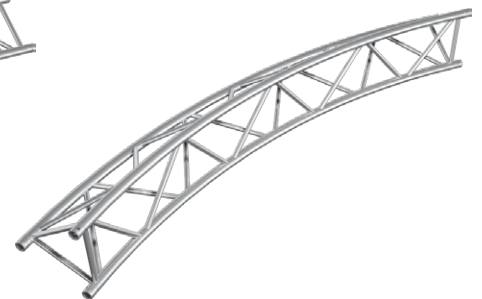

FT43-C3		HT43-C3	
	Circle, apex out, various diameters		



SPECIFICATIONS

Tubes	50 x 2 mm (1.97 x 0.08 in)
Braces	25 x 3 mm (0.98 x 0.12 in)
Alloy	EN AW-6082 T6

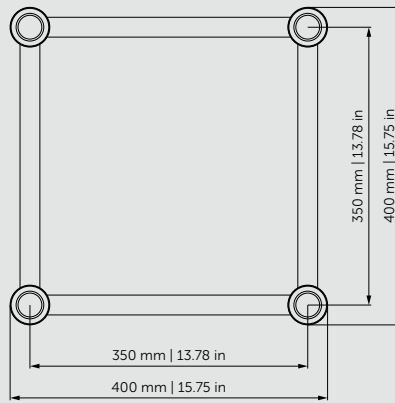

LOADING TABLES

		2 m	4 m	6 m	8 m	10 m	12 m	14 m	16 m
UDL [kg/m]		1805	595	274	163	106	73	52	38
Deflection [mm]		1.5	7.8	18.4	35.2	57.3	83.5	114.9	151.1
CPL [kg]		1805	1190	823	653	532	436	364	304
Deflection [mm]		1.2	6.2	14.8	28.5	46.6	68.4	94.7	124.5
		6.56 ft	13.12 ft	19.68 ft	26.24 ft	32.81 ft	39.37 ft	45.93 ft	52.49 ft
UDL [lbs/ft]		1213.1	399.9	184.1	109.5	71.2	49.1	34.9	25.5
Deflection [in]		0.1	0.3	0.7	1.4	2.3	3.3	4.5	5.9
CPL [lbs]		3980	2624	1814.7	1439.9	1173.1	961.4	802.6	670.3
Deflection [in]		0.05	0.2	0.6	1.1	1.8	2.7	3.7	4.9

Loading tables are valid for static loads and spans with two supporting points.

Spans must be supported at each end.

Contact structural engineer if there are more supporting points applied or dynamic and wind loads involved.

STRAIGHT SEGMENT LENGTHS

Code	Length		Weight	
FT44-50	0.5 m	1.64 ft	5.0 kg	11.02 lbs
FT44-100	1 m	3.28 ft	8.37 kg	18.45 lbs
FT44-150	1.5 m	4.92 ft	11.30 kg	24.92 lbs
FT44-200	2 m	6.56 ft	14.10 kg	31.08 lbs
FT44-250	2.5 m	8.20 ft	16.98 kg	37.44 lbs
FT44-300	3 m	9.84 ft	20.24 kg	44.62 lbs
FT44-350	3.5 m	11.48 ft	23.05 kg	50.81 lbs
FT44-400	4 m	13.12 ft	26.10 kg	57.53 lbs
FT44-450	4.5 m	14.76 ft	28.78 kg	63.46 lbs
FT44-500	5 m	16.40 ft	32.00 kg	70.55 lbs

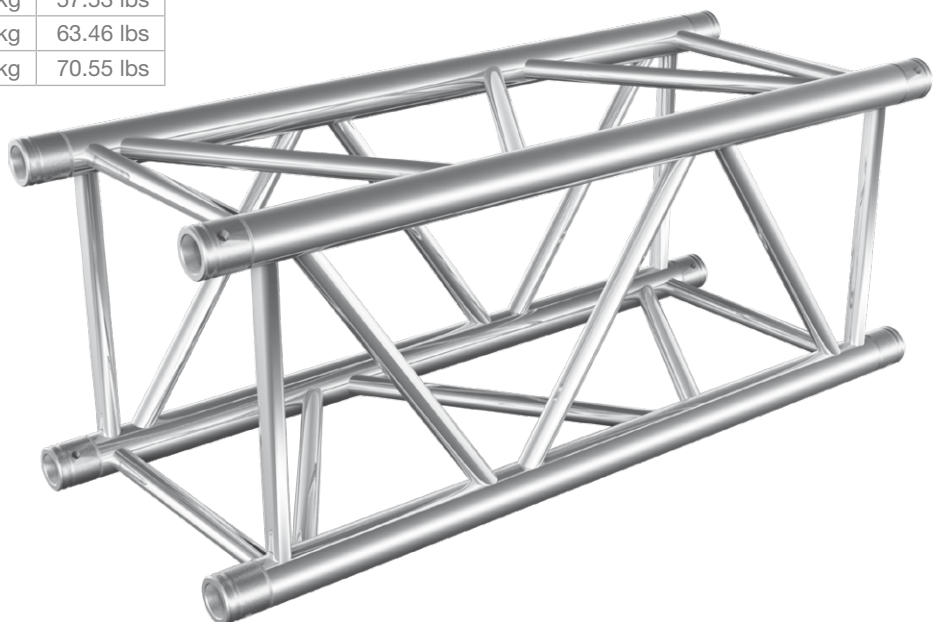

SPECIFICATIONS

Tubes	50 x 3 mm (1.97 x 0.12 in)
Braces	25 x 3 mm (0.98 x 0.12 in)
Alloy	EN AW-6082 T6

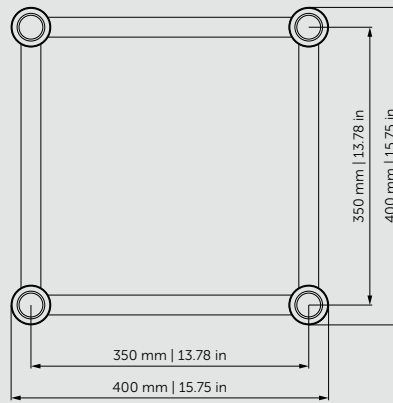

LOADING TABLES

		2 m	4 m	6 m	8 m	10 m	12 m	14 m	16 m
UDL [kg/m]		2327	901	417	243	162	112	82	61
Deflection [mm]		1.3	8	18.9	35.4	58.8	86.5	119.8	158.7
CPL [kg]		3267	1803	1252	971	811	675	573	477
Deflection [mm]		1.4	6.4	15.2	28.5	47.6	70.5	98.3	127.8
		6.56 ft	13.12 ft	19.68 ft	26.24 ft	32.81 ft	39.37 ft	45.93 ft	52.49 ft
UDL [lbs/ft]		1563.9	605.5	280.2	163.3	108.9	75.3	55.1	41
Deflection [in]		0.1	0.3	0.7	1.4	2.3	3.4	4.7	6.2
CPL [lbs]		7203.7	3975.6	2760.7	2141.1	1788.3	1488.4	1263.5	1051.8
Deflection [in]		0.1	0.3	0.6	1.1	1.9	2.8	3.9	5

Loading tables are valid for static loads and spans with two supporting points.

Spans must be supported at each end.

Contact structural engineer if there are more supporting points applied or dynamic and wind loads involved.

STRAIGHT SEGMENT LENGTHS

Code	Length		Weight	
HT44-50	0.5 m	1.64 ft	5.54 kg	12.22 lbs
HT44-100	1 m	3.28 ft	9.67 kg	21.32 lbs
HT44-150	1.5 m	4.92 ft	13.37 kg	29.47 lbs
HT44-200	2 m	6.56 ft	16.92 kg	37.30 lbs
HT44-250	2.5 m	8.20 ft	20.57 kg	45.34 lbs
HT44-300	3 m	9.84 ft	24.58 kg	54.20 lbs
HT44-350	3.5 m	11.48 ft	28.15 kg	62.06 lbs
HT44-400	4 m	13.12 ft	31.96 kg	70.46 lbs
HT44-450	4.5 m	14.76 ft	35.41 kg	78.06 lbs
HT44-500	5 m	16.40 ft	39.38 kg	86.83 lbs

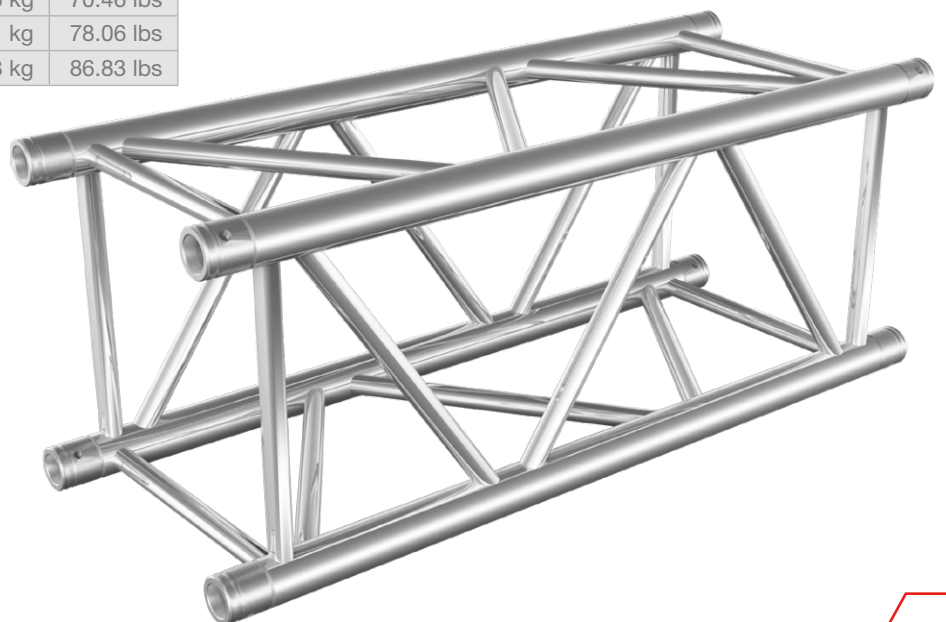

FT44 / HT44

QUICKLOCK LINE

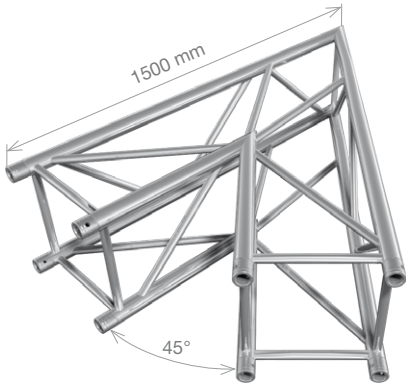

FT44-C19	HT44-C19
2-way 45° corner	
1.5 m (4.92 ft)	
14.09 kg (31.07 lbs)	17.15 kg (37.81 lbs)

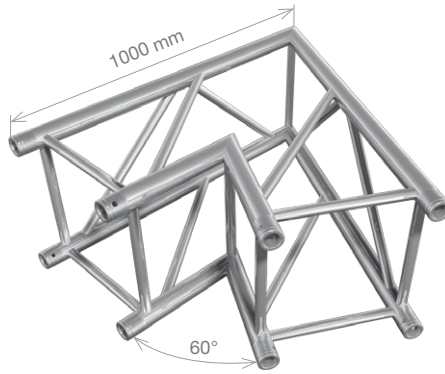

FT44-C20	HT44-C20
2-way 60° corner	
1 m (3.28 ft)	
9.50 kg (20.94 lbs)	11.40 kg (25.13 lbs)

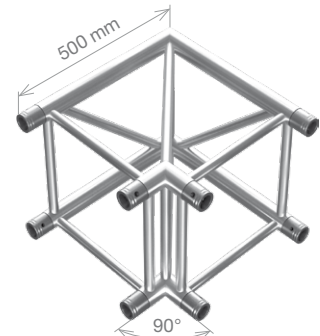

FT44-C21	HT44-C21
2-way 90° corner	
0.5 m (1.64 ft)	
6.08 kg (13.41 lbs)	6.70 kg (14.78 lbs)

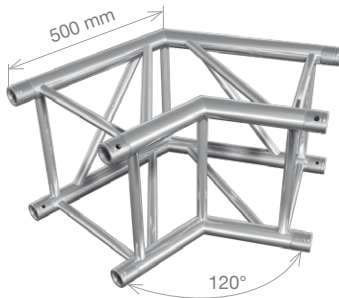

FT44-C22	HT44-C22
2-way 120° corner	
0.5 m (1.64 ft)	
6.74 kg (14.87 lbs)	6.68 kg (14.73 lbs)

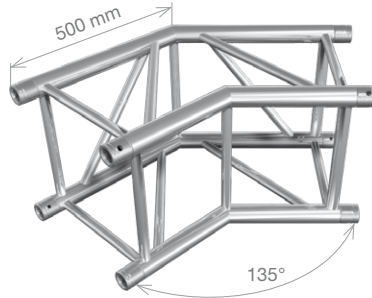

FT44-C23	HT44-C23
2-way 135° corner	
0.5 m (1.64 ft)	
6.93 kg (15.28 lbs)	7.33 kg (16.16 lbs)

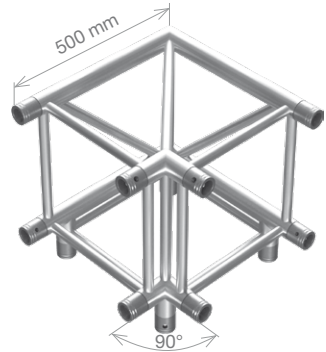

FT44-C30	HT44-C30
3-way 90° corner	
0.5 m (1.64 ft)	
7.70 kg (16.98 lbs)	8.38 kg (18.47 lbs)

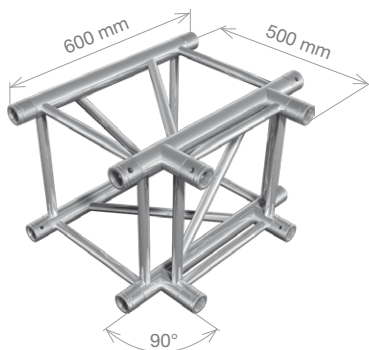

FT44-T35	HT44-T35
3-way T-junction	
0.6 x 0.5 m (1.97 x 1.64 ft)	
6.94 kg (15.30 lbs)	7.69 kg (16.95 lbs)

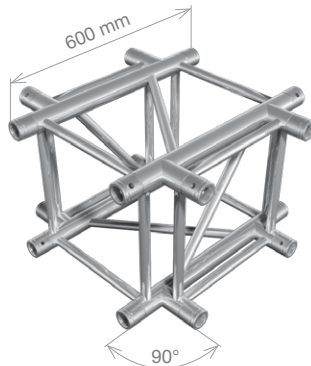

FT44-C41	HT44-C41
4-way cross junction	
0.6 m (1.97 ft)	
8.56 kg (18.85 lbs)	9.35 kg (20.62 lbs)

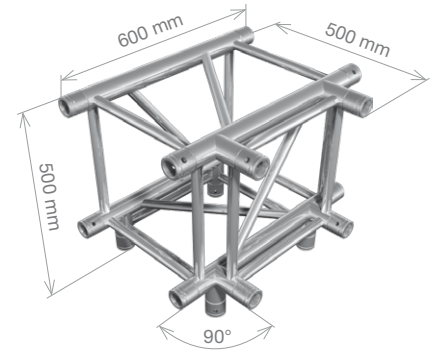

FT44-T42	HT44-T42
4-way T-junction	
0.6 x 0.5 x 0.5 m (1.97 x 1.64 x 1.64 ft)	
8.56 kg (18.85 lbs)	9.35 kg (20.62 lbs)

CORNERS

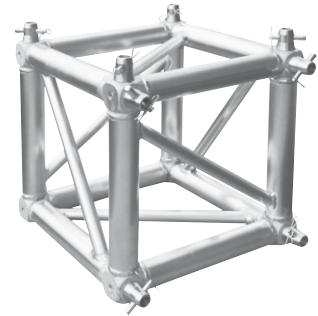
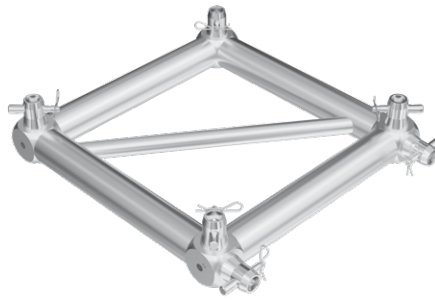
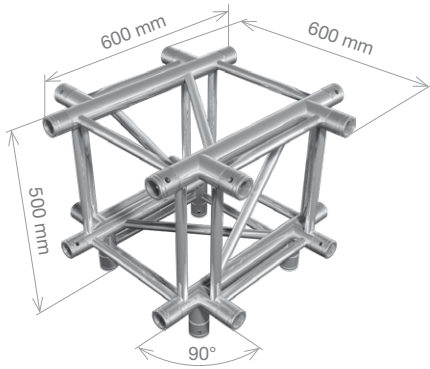

FT44-T51

HT44-T51

	5-way junction
	0.6 x 0.6 x 0.5 m (1.97 x 1.97 x 1.64 ft)
	9.42 kg (20.78 lbs)
	11.02 kg (24.29 lbs)

FT44-42F

HT44-42F

	Frame FT44+FT42 / Frame HT44+HT42
	0.4 x 0.4 m (1.31 x 1.31 ft)
	3.37 kg (7.43 lbs)
	3.79 kg (8.35 lbs)

Includes connection sets for two ways.

FT44-MCB

HT44-MCB

	Multi connection box
	0.4 x 0.4 m (1.31 x 1.31 ft)
	11.27 kg (24.84 lbs)
	12.53 kg (27.63 lbs)

Includes connection sets for two ways.

CIRCLES

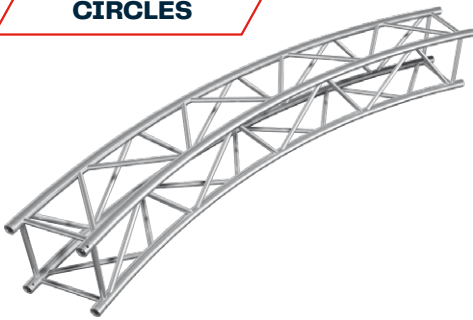

FT44-C

HT44-C

	Circle, various diameters
--	---------------------------

SPECIFICATIONS

Tubes	50 x 3 mm (1.97 x 0.12 in)
Braces	25 x 3 mm (0.98 x 0.12 in)
Alloy	EN AW-6082 T6

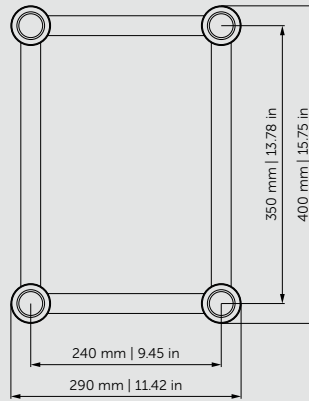

LOADING TABLES

		6 m	8 m	10 m	12 m	14 m	16 m	18 m
UDL [kg/m]		464	261	167	115	85	63	47
Deflection [mm]		20.9	37.5	59.2	85.8	119.3	154.1	190
CPL [kg]		1392	1045	833	688	592	501	421
Deflection [mm]		16.8	30.2	47.7	69.5	97	126	156.3
		19.68 ft	26.24 ft	32.81 ft	39.37 ft	45.93 ft	52.49 ft	59.05 ft
UDL [lbs/ft]		311.8	175.4	112.2	77.3	57.1	42.3	31.6
Deflection [in]		0.8	1.5	2.3	3.4	4.7	6.1	7.5
CPL [lbs]		3069.4	2304.2	1836.8	1517	1305.4	1104.7	928.3
Deflection [in]		0.7	1.2	1.9	2.7	3.8	5	6.2

Loading tables are valid for static loads and spans with two supporting points. Spans must be supported at each end.

Contact structural engineer if there are more supporting points applied or dynamic and wind loads involved.

STRAIGHT SEGMENT LENGTHS

Code	Length		Weight	
FTR4030-50	0.5 m	1.64 ft	7.98 kg	17.60 lbs
FTR4030-100	1 m	3.28 ft	11.67 kg	25.73 lbs
FTR4030-150	1.5 m	4.92 ft	14.93 kg	32.92 lbs
FTR4030-200	2 m	6.56 ft	18.12 kg	39.95 lbs
FTR4030-250	2.5 m	8.20 ft	21.36 kg	47.08 lbs
FTR4030-300	3 m	9.84 ft	24.99 kg	55.09 lbs
FTR4030-350	3.5 m	11.48 ft	28.18 kg	62.14 lbs
FTR4030-400	4 m	13.12 ft	31.50 kg	69.45 lbs

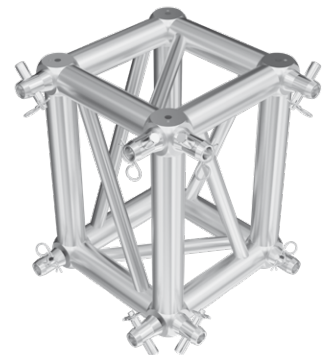
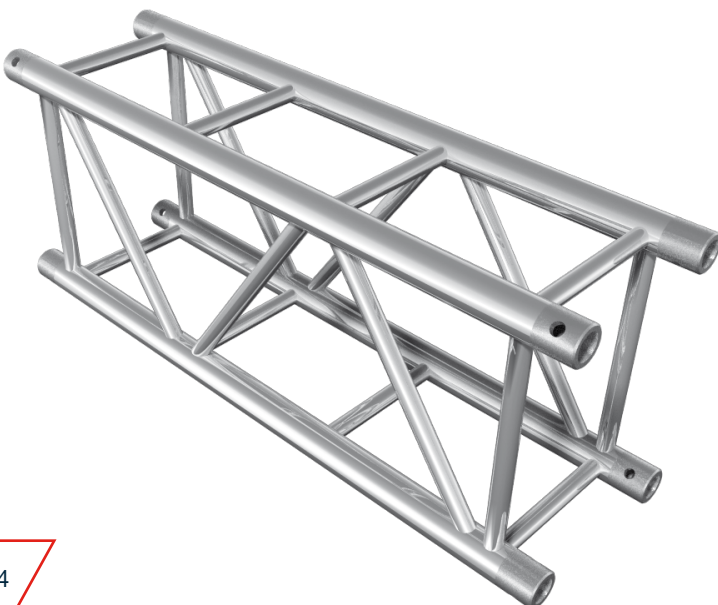

FTR4030-MCB

	Multi connection box
	0.29 x 0.35 x 0.29 m (0.95 x 1.15 x 0.95 ft)
	9.51 kg (20.97 lbs)

Includes connection sets for two ways.

SPECIFICATIONS

Tubes	50 x 4 mm (1.97 x 0.16 in)
Braces	20 x 2 mm (0.79 x 0.08 in)
Alloy	EN AW-6082 T6

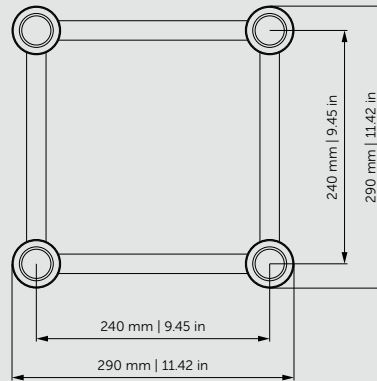

LOADING TABLES

		2 m	3 m	4 m	6 m	8 m	10 m	12 m	14 m	16 m	18 m	20 m
UDL [kg/m]		1418	943	705	450	251	157	107	74	51	33	13
Deflection [mm]		1.3	4.3	10.2	33.3	59.4	92.8	134	177.9	219.8	243.9	198.4
CPL [kg]		2845	2744	2060	1351	1002	785	639	517	408	293	131
Deflection [mm]		2	6.7	11.9	26.7	47.9	75.2	109.3	146.2	182.5	205.8	175
TPL [kg]		1418	1414	1410	1013	752	589	479	387	306	219	98
Deflection [mm]		1.7	5.9	13.9	34	60.7	94.7	136.7	181.4	223.9	248.2	201
QPL [kg]		946	943	940	675	501	393	320	258	204	146	66
Deflection [mm]		1.6	5.4	12.9	31.6	56.5	88.4	127.8	169.9	210.5	234.4	192.6
FLP [kg]		709	707	705	563	418	327	266	215	170	122	55
Deflection [mm]		1.6	5.2	12.4	33.8	60.4	94.3	136.1	180.6	223	247.2	200.4
		6.56 ft	9.84 ft	13.12 ft	19.69 ft	26.25 ft	32.81 ft	39.37 ft	45.93 ft	52.49 ft	59.06 ft	65.62 ft
UDL [lbs/ft]		952.85	633.67	473.74	302.39	168.66	105.50	71.90	49.73	34.27	22.17	8.74
Deflection [in]		0.05	0.17	0.40	1.31	2.34	3.65	5.28	7.00	8.65	9.60	7.81
CPL [lbs]		6272.15	6049.48	4541.52	2978.45	2209.03	1730.63	1408.75	1139.79	899.49	645.95	288.81
Deflection [in]		0.08	0.26	0.47	1.05	1.89	2.96	4.30	5.76	7.19	8.10	6.89
TPL [lbs]		3126.15	3117.34	3108.52	2233.28	1657.88	1298.52	1056.01	853.19	674.61	482.81	216.05
Deflection [in]		0.07	0.23	0.55	1.34	2.39	3.73	5.38	7.14	8.81	9.77	7.91
QPL [lbs]		2085.57	2078.96	2072.35	1488.12	1104.52	866.42	705.48	568.79	449.74	321.87	145.51
Deflection [in]		0.06	0.21	0.51	1.24	2.22	3.48	5.03	6.69	8.29	9.23	7.58
FLP [lbs]		1563.08	1558.67	1554.26	1241.20	921.53	720.91	586.43	473.99	374.79	268.96	121.25
Deflection [in]		0.06	0.20	0.49	1.33	2.38	3.71	5.36	7.11	8.78	9.73	7.89

Loading tables are valid for static loads and spans with two supporting points. Spans must be supported at each end. Contact structural engineer if there are more supporting points applied or dynamic and wind loads involved.

STRAIGHT SEGMENT LENGTHS

Code	Length		Weight	
TT34-100	1 m	3.28 ft	9.55 kg	21.06 lbs
TT34-150	1.5 m	4.92 ft	13.42 kg	29.59 lbs
TT34-200	2 m	6.56 ft	17.29 kg	38.11 lbs
TT34-250	2.5 m	8.20 ft	21.16 kg	46.64 lbs
TT34-300	3 m	9.84 ft	25.02 kg	55.17 lbs
TT34-350	3.5 m	11.48 ft	28.64 kg	63.13 lbs
TT34-400	4 m	13.12 ft	32.76 kg	72.22 lbs
TT34-500	5 m	14.76 ft	40.50 kg	89.28 lbs



SPECIFICATIONS

Tubes	50 x 4 mm (1.97 x 0.16 in)
Braces	25 x 3 mm (0.98 x 0.12 in)
Alloy	EN AW-6082 T6

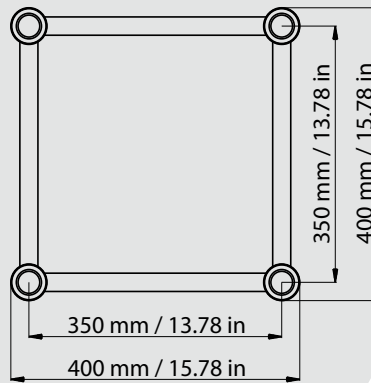

LOADING TABLES

		2 m	4 m	6 m	8 m	10 m	12 m	14 m	16 m	18 m	20 m
UDL [kg/m]		2126	1057	700	390	245	166	119	88	66	50
Deflection [mm]		0.9	7.2	24.3	43.5	68.1	98.3	134.2	175.8	221.8	267.2
CPL [kg]		4253	3197	2111	1561	1226	999	833	705	596	496
Deflection [mm]		1.4	8.7	19.6	35.1	55.2	80.2	110.1	145.4	184.6	225.5
TPL [kg]		2137	2136	1583	1171	920	749	625	529	447	372
Deflection [mm]		1.2	9.9	25	44.4	69.5	100.3	136.8	179.2	225.1	271.8
QPL [kg]		1424	1423	1055	781	613	499	416	353	298	248
Deflection [mm]		1.1	9.2	23.2	41.4	64.9	93.8	128.1	168.2	212	256.7
		6.56 ft	13.12 ft	19.69 ft	26.25 ft	32.81 ft	39.37 ft	45.93 ft	52.49 ft	59.06 ft	65.62 ft
UDL [lbs/ft]		1428.61	710.27	470.38	262.07	164.63	111.55	79.96	59.13	44.35	33.60
Deflection [in]		0.04	0.28	0.96	1.71	2.68	3.87	5.28	6.92	8.73	10.52
CPL [lbs]		9376.26	7048.18	4653.96	3441.42	2702.87	2202.42	1836.45	1554.26	1313.96	1093.49
Deflection [in]		0.06	0.34	0.77	1.38	2.17	3.16	4.33	5.72	7.27	8.88
TPL [lbs]		4711.28	4709.07	3489.92	2581.61	2028.25	1651.26	1377.89	1166.25	985.47	820.12
Deflection [in]		0.05	0.39	0.98	1.75	2.74	3.95	5.39	7.06	8.86	10.70
QPL [lbs]		3139.38	3137.18	2325.88	1721.81	1351.43	1100.11	917.12	778.23	656.98	546.75
Deflection [in]		0.04	0.36	0.91	1.63	2.56	3.69	5.04	6.62	8.35	10.11

Loading tables are valid for static loads and spans with two supporting points. Spans must be supported at each end. Contact structural engineer if there are more supporting points applied or dynamic and wind loads involved.

STRAIGHT SEGMENT LENGTHS

Code	Length		Weight	
TT44-50	0.5 m	1.64 ft	6.98 kg	15.40 lbs
TT44-100	1 m	3.28 ft	11.85 kg	26.13 lbs
TT44-150	1.5 m	4.92 ft	16.29 kg	35.91 lbs
TT44-200	2 m	6.56 ft	20.58 kg	45.37 lbs
TT44-250	2.5 m	8.20 ft	24.97 kg	55.05 lbs
TT44-300	3 m	9.84 ft	29.72 kg	65.53 lbs
TT44-350	3.5 m	11.48 ft	34.20 kg	75.40 lbs
TT44-400	4 m	13.12 ft	38.58 kg	85.05 lbs
TT44-450	4.5 m	14.76 ft	42.72 kg	94.18 lbs
TT44-500	5 m	16.40 ft	47.80 kg	105.38 lbs

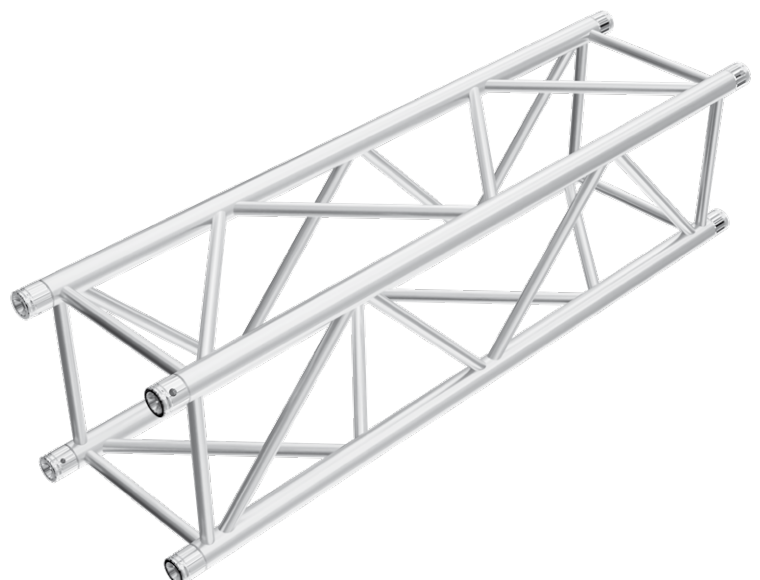

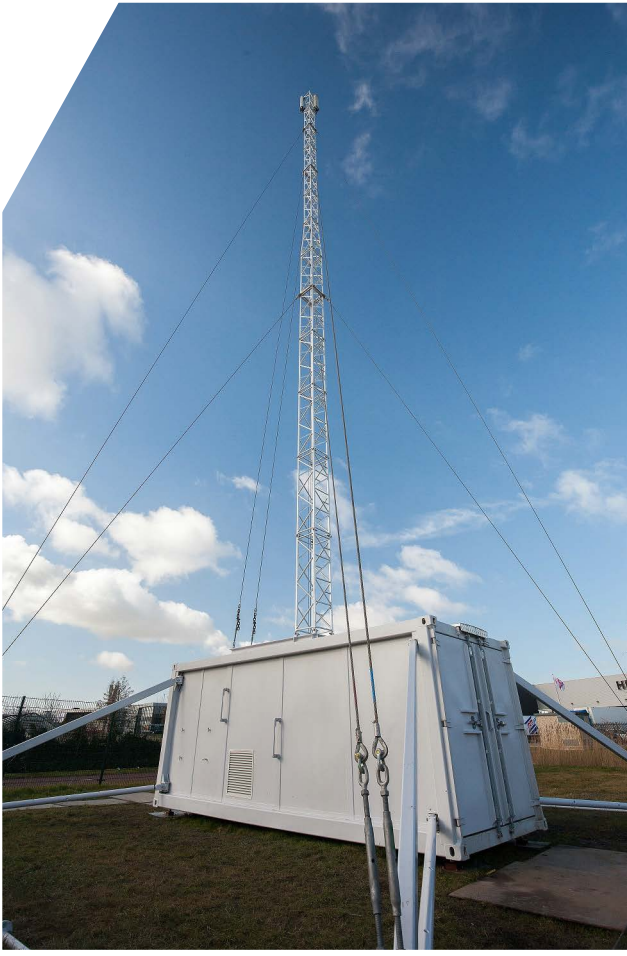

SPECIFICATIONS

Tubes	50 x 4 mm (1.97 x 0.16 in)
Braces	20 x 2 mm (0.79 x 0.08 in)
Plates	8 mm (0.31 in)
Alloy	EN AW-6082 T6

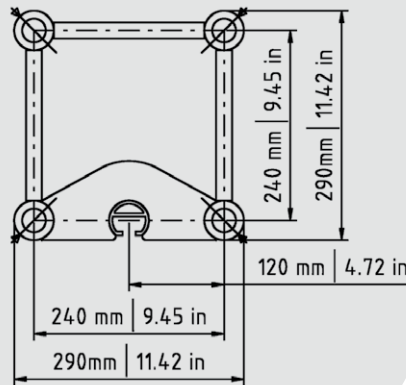

LOADING TABLES - COMPLETE TRUSS

		4 m	5 m	6 m	7 m	8 m	10 m	12 m	14 m	16 m	18 m	20 m
UDL [kg/m]		746	594	456	331	251	155	104	73	53	39	29
Deflection [mm]		10	20	33	45	59	92	133	181	238	303	377
CPL [kg]		2085	1656	1368	1160	1002	777	623	509	420	303	287
Deflection [mm]		12	18	26	36	47	75	109	151	201	259	327
TPL [kg]		1412	1242	1026	870	752	583	467	382	315	261	216
Deflection [mm]		14	23	33	45	58	87	121	157	193	228	258
QPL [kg]		941	828	684	580	501	389	312	254	210	174	144
Deflection [mm]		13	22	31	41	53	81	112	146	179	211	240
FPL [kg]		706	684	570	483	418	324	260	212	175	145	120
Deflection [mm]		12	23	33	44	57	86	119	154	190	224	254
		13.12 ft	16.40 ft	19.69 ft	22.97 ft	26.25 ft	32.81 ft	39.37 ft	45.93 ft	52.49 ft	59.06 ft	65.62 ft
UDL [lbs/ft]		501.29	399.15	306.42	222.42	168.66	104.16	69.88	49.05	35.61	26.21	19.49
Deflection [in]		0.39	0.79	1.30	1.77	2.32	3.62	5.24	7.13	9.37	11.93	14.84
CPL [lbs]		4596.64	3650.86	3015.92	2557.36	2209.03	1712.99	1373.48	1122.15	925.94	668.00	632.73
Deflection [in]		0.47	0.71	1.02	1.42	1.85	2.95	4.29	5.94	7.91	10.20	12.87
TPL [lbs]		3112.93	2738.14	2261.94	1918.02	1657.88	1285.29	1029.56	842.17	694.46	575.41	476.20
Deflection [in]		0.55	0.91	1.30	1.77	2.28	3.43	4.76	6.18	7.60	8.98	10.16
QPL [lbs]		2074.55	1825.43	1507.96	1278.68	1104.52	857.60	687.84	559.97	462.97	383.60	317.47
Deflection [in]		0.51	0.87	1.22	1.61	2.09	3.19	4.41	5.75	7.05	8.31	9.45
FPL [lbs]		1556.46	1507.96	1256.63	1064.83	921.53	714.30	573.20	467.38	385.81	319.67	264.55
Deflection [in]		0.47	0.91	1.30	1.73	2.24	3.39	4.69	6.06	7.48	8.82	10.00

Loading tables are valid for static loads and spans with two supporting points. Spans must be supported at each end. Contact structural engineer if there are more supporting points applied or dynamic and wind loads involved.

STRAIGHT SEGMENT LENGTHS

Code	Length		Weight	
	m	ft	kg	lbs
TC35-50	0.5 m	1.64 ft	7 kg	15.43 lbs
TC35-100	1 m	3.28 ft	12.2 kg	26.90 lbs
TC35-150	1.5 m	4.92 ft	17.5 kg	38.58 lbs
TC35-200	2 m	6.56 ft	21.5 kg	47.40 lbs
TC35-250	2.5 m	8.20 ft	26.5 kg	58.42 lbs
TC35-300	3 m	9.84 ft	31 kg	68.34 lbs

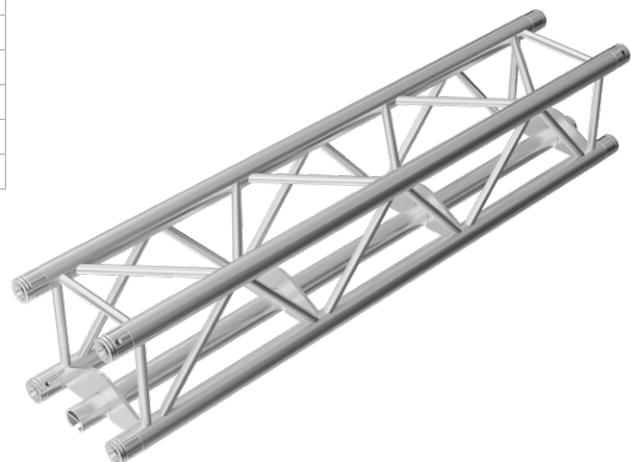



LOADING TABLES - CENTRAL BOTTOM TUBE

		4 m	5 m	6 m	7 m	8 m	10 m	12 m	14 m	16 m	18 m	20 m
UDL [kg/m]		746	594	456	331	251	155	104	73	53	39	29
Deflection [mm]		10	20	33	45	59	92	133	181	238	303	377
CPL [kg]		800	800	800	800	800	777	623	509	420	348	287
Deflection [mm]		5	9	16	26	39	75	109	151	201	259	327
TPL [kg]		800	800	800	800	752	583	467	382	315	261	216
Deflection [mm]		8	15	26	41	58	87	121	157	193	228	258
QPL [kg]		800	800	684	580	501	389	312	254	210	174	144
Deflection [mm]		11	21	31	41	53	81	112	146	179	211	240
FPL [kg]		706	684	570	483	418	324	260	212	175	145	120
Deflection [mm]		12	23	33	44	57	86	119	154	190	224	254
		13.12 ft	16.40 ft	19.69 ft	22.97 ft	26.25 ft	32.81 ft	39.37 ft	45.93 ft	52.49 ft	59.06 ft	65.62 ft
UDL [lbs/ft]		501.29	399.15	306.42	222.42	168.66	104.16	69.88	49.05	35.61	26.21	19.49
Deflection [in]		0.39	0.79	1.30	1.77	2.32	3.62	5.24	7.13	9.37	11.93	14.84
CPL [lbs]		1763.70	1763.70	1763.70	1763.70	1763.70	1712.99	1373.48	1122.15	925.94	767.21	632.73
Deflection [in]		0.20	0.35	0.63	1.02	1.54	2.95	4.29	5.94	7.91	10.20	12.87
TPL [lbs]		1763.70	1763.70	1763.70	1763.70	1657.88	1285.29	1029.56	842.17	694.46	575.41	476.20
Deflection [in]		0.31	0.59	1.02	1.61	2.28	3.43	4.76	6.18	7.60	8.98	10.16
QPL [lbs]		1763.70	1763.70	1507.96	1278.68	1104.52	857.60	687.84	559.97	462.97	383.60	317.47
Deflection [in]		0.43	0.83	1.22	1.61	2.09	3.19	4.41	5.75	7.05	8.31	9.45
FPL [lbs]		1556.46	1507.96	1256.63	1064.83	921.53	714.30	573.20	467.38	385.81	319.67	264.55
Deflection [in]		0.47	0.91	1.30	1.73	2.24	3.39	4.69	6.06	7.48	8.82	10.00

Loading tables are valid for static loads and spans with two supporting points. Spans must be supported at each end. Contact structural engineer if there are more supporting points applied or dynamic and wind loads involved.

SPECIFICATIONS

 Tubes 	50 x 4 mm (1.97 x 0.16 in)
 Braces 	25 x 3 mm (0.98 x 0.12 in)
 Plates 	8 mm (0.31 in)
 Alloy 	EN AW-6082 T6

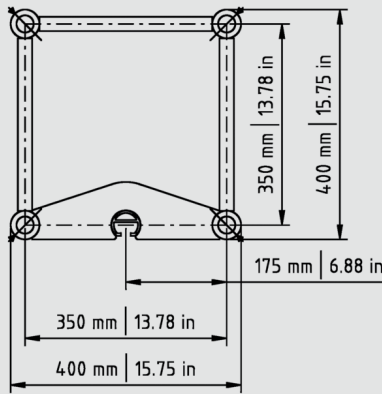

LOADING TABLES - COMPLETE TRUSS

		4 m	5 m	6 m	7 m	8 m	10 m	12 m	14 m	16 m	18 m	20 m
UDL [kg/m]		1469	951	655	477	362	226	152	107	78	58	44
Deflection [mm]		10	15	22	30	40	62	90	123	161	205	254
CPL [kg]		2626	2260	1966	1670	1446	1128	910	750	626	526	442
Deflection [mm]		7	12	18	25	32	51	74	102	135	174	218
TPL [kg]		1660	1460	1301	1172	1066	846	683	563	469	394	332
Deflection [mm]		8	13	20	29	39	60	84	110	136	163	188
QPL [kg]		1107	973	867	782	711	564	455	375	313	263	221
Deflection [mm]		7	12	19	27	36	56	78	102	127	152	175
FPL [kg]		876	775	694	628	573	470	379	313	261	219	184
Deflection [mm]		7	12	19	27	37	59	83	108	135	161	186
		13.12 ft	16.40 ft	19.69 ft	22.97 ft	26.25 ft	32.81 ft	39.37 ft	45.93 ft	52.49 ft	59.06 ft	65.62 ft
UDL [lbs/ft]		987.12	639.04	440.14	320.53	243.25	151.87	102.14	71.90	52.41	38.97	29.57
Deflection [in]		0.39	0.59	0.87	1.18	1.57	2.44	3.54	4.84	6.34	8.07	10.00
CPL [lbs]		5789.34	4982.45	4334.29	3681.72	3187.88	2486.81	2006.21	1653.47	1380.09	1159.63	974.44
Deflection [in]		0.28	0.47	0.71	0.98	1.26	2.01	2.91	4.02	5.31	6.85	8.58
TPL [lbs]		3659.67	3218.75	2868.21	2583.82	2350.13	1865.11	1505.76	1241.20	1033.97	868.62	731.93
Deflection [in]		0.31	0.51	0.79	1.14	1.54	2.36	3.31	4.33	5.35	6.42	7.40
QPL [lbs]		2440.52	2145.10	1911.41	1724.01	1567.49	1243.41	1003.10	826.73	690.05	579.82	487.22
Deflection [in]		0.28	0.47	0.75	1.06	1.42	2.20	3.07	4.02	5.00	5.98	6.89
FPL [lbs]		1931.25	1708.58	1530.01	1384.50	1263.25	1036.17	835.55	690.05	575.41	482.81	405.65
Deflection [in]		0.28	0.47	0.75	1.06	1.46	2.32	3.27	4.25	5.31	6.34	7.32

Loading tables are valid for static loads and spans with two supporting points. Spans must be supported at each end. Contact structural engineer if there are more supporting points applied or dynamic and wind loads involved.

STRAIGHT SEGMENT LENGTHS

Code	Length		Weight	
	m	ft	kg	lbs
TC45-50	0.5 m	1.64 ft	8.4 kg	18.52 lbs
TC45-100	1 m	3.28 ft	14.7 kg	32.41 lbs
TC45-150	1.5 m	4.92 ft	20.6 kg	45.42 lbs
TC45-200	2 m	6.56 ft	25.1 kg	55.34 lbs
TC45-250	2.5 m	8.20 ft	31 kg	68.34 lbs
TC45-300	3 m	9.84 ft	36.9 kg	81.37 lbs

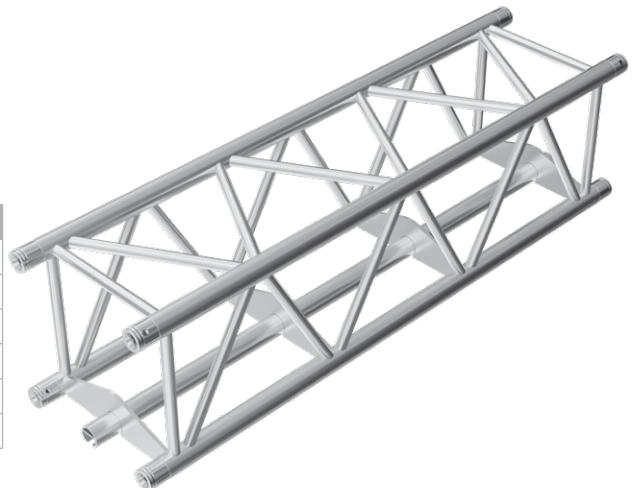



LOADING TABLES – CENTRAL BOTTOM TUBE

		4 m	5 m	6 m	7 m	8 m	10 m	12 m	14 m	16 m	18 m	20 m
UDL [kg/m]		800	800	655	477	362	226	152	107	78	58	44
Deflection [mm]		5	13	22	30	40	62	90	123	161	205	254
CPL [kg]		800	800	800	800	800	800	800	750	626	526	442
Deflection [mm]		2	4	8	12	19	37	66	102	135	174	218
TPL [kg]		800	800	800	800	800	800	683	563	469	394	332
Deflection [mm]		4	7	12	19	29	57	84	110	136	163	188
QPL [kg]		800	800	800	782	711	564	455	375	313	263	221
Deflection [mm]		5	10	17	27	36	56	78	102	127	152	175
FPL [kg]		800	775	694	628	573	470	379	313	261	219	184
Deflection [mm]		6	12	19	27	37	59	83	108	135	161	186
		13.12 ft	16.40 ft	19.69 ft	22.97 ft	26.25 ft	32.81 ft	39.37 ft	45.93 ft	52.49 ft	59.06 ft	65.62 ft
UDL [lbs/ft]		537.58	537.58	440.14	320.53	243.25	151.87	102.14	71.90	52.41	38.97	29.57
Deflection [in]		0.20	0.51	0.87	1.18	1.57	2.44	3.54	4.84	6.34	8.07	10.00
CPL [lbs]		1763.70	1763.70	1763.70	1763.70	1763.70	1763.70	1763.70	1653.47	1380.09	1159.63	974.44
Deflection [in]		0.08	0.16	0.31	0.47	0.75	1.46	2.60	4.02	5.31	6.85	8.58
TPL [lbs]		1763.70	1763.70	1763.70	1763.70	1763.70	1763.70	1505.76	1241.20	1033.97	868.62	731.93
Deflection [in]		0.16	0.28	0.47	0.75	1.14	2.24	3.31	4.33	5.35	6.42	7.40
QPL [lbs]		1763.70	1763.70	1763.70	1724.01	1567.49	1243.41	1003.10	826.73	690.05	579.82	487.22
Deflection [in]		0.20	0.39	0.67	1.06	1.42	2.20	3.07	4.02	5.00	5.98	6.89
FPL [lbs]		1763.70	1708.58	1530.01	1384.50	1263.25	1036.17	835.55	690.05	575.41	482.81	405.65
Deflection [in]		0.24	0.47	0.75	1.06	1.46	2.32	3.27	4.25	5.31	6.34	7.32

Loading tables are valid for static loads and spans with two supporting points. Spans must be supported at each end. Contact structural engineer if there are more supporting points applied or dynamic and wind loads involved.



3118

Connection set for FT31



3124

Connection set for FT32, HT32,
FT42, HT42



3135

Connection set for FT33, HT33,
FT43, HT43

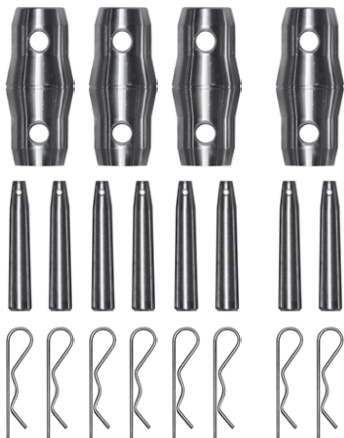

3146

Connection set for FT34, HT34,
FT44, TC35, TC45



4346

Connection set for FTR4030



3101

Conical connector, diam. 36 mm
(1.42 in) FT31-TC45



4341

Conical connector, diam. 36 mm
(1.42 in) FTR4030



3102

Male spacer 10 mm (0.39 in),
FT31-TC45



3103

Male spacer 20 mm (0.79 in),
FT31-TC45



3104

Male spacer 30 mm (1.18 in),
FT31-TC45



3105

Male spacer 40 mm (1.57 in),
FT31-TC45



3106

Male spacer 50 mm (1.96 in),
FT31-TC45



3107

Male spacer 55 mm (2.17 in),
FT31-TC45



3108

Adjustable spacer 120-170 mm
(4.72-6.69 in)



3110

Aluminium male halfconnector,
10 mm (0.39 in) offset with M10
thread, FT31-TC45



3111

Aluminium male halfconnector,
10 mm (0.39 in) offset with M12
thread, FT31-TC45



3113

Aluminium male halfconnector
with M10 thread, FT31-TC45



3114

Aluminium male halfconnector
with M12 thread, FT31-TC45



3115

Steel male halfconnector with M10 thread, FT31-TC45



3116

Steel male halfconnector for M12 screw, FT31-TC45



3117

Female fitting 75 mm (2.95 in) for FT34-MCB, FT44-MCB



3120

Female spacer 105 mm (4.13 in), FT31-TC45



3121

Female spacer 170 mm (6.69 in), FT31-TC45



3122

Female spacer 210 mm (8.27 in), FT31-TC45



3150

Pin for FT31-TC45



3151

Pin with M8 thread, FT31-TC45



4342

Pin for FTR4030



4344

Pin with M10 thread, FTR4030



3152

Safety clip for FT31-TC45



4343

Safety clip for FTR4030



4345

Female fitting FTR4030 for M12 screw



3109

Endcap FT31-TC45



8202

Corner brace in different lengths



9502

Universal TV Holder FT32-TC45

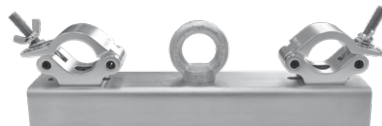

8013

Truss Holder FT32-TC45 1000 kg (2,204 lbs)



8201

Universal clamp in different lengths

ACCESSORIES FT31-TC45

QUICKLOCK LINE



8203

Truss ring for FT34, HT34, TC35



8204

Clamp on outrigger for FT31-34

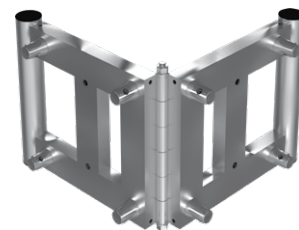

8301

Book corner for FT33, HT33, FT34, HT34, TC35

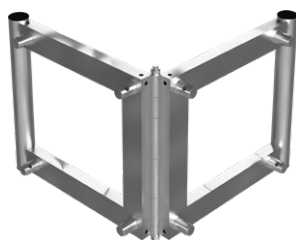

8302

Book corner for FT44, HT44, TC45

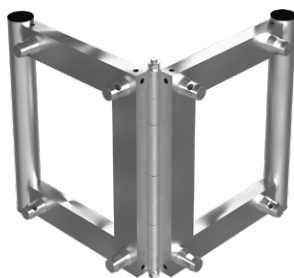

8303

Book corner for FTR4030



8304

Plated book corner for FT33, HT33, FT34, HT34, TC35

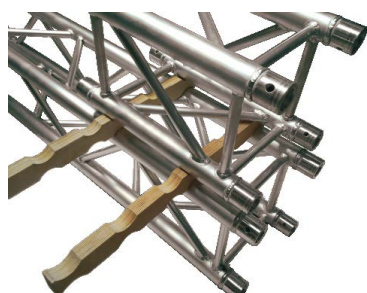

8008

Plastic carriers for FT33, HT33, FT34, HT34, TC35

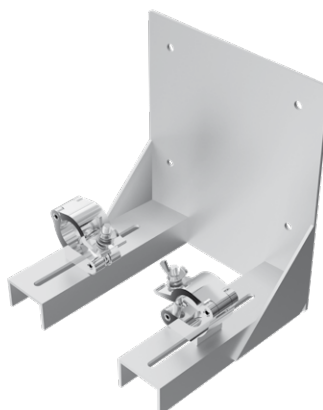

8402

Wall plate console



3001

Male base plate for FT31

3001/W

Male wall plate for FT31



3002

Male base plate for FT32

3002/W

Male wall plate for FT32



3003

Male base plate for FT33

3003/W

Male wall plate for FT33



3004

Male base plate for FT34

3004/W

Male wall plate for FT34



3002/F

Female base plate for FT32

3002/F/W

Female wall plate for FT32

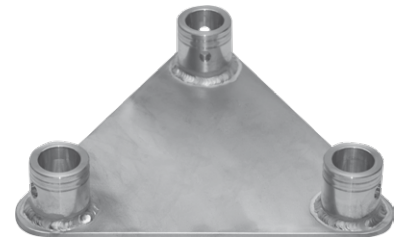

3003/F

Female base plate for FT33

3003/F/W

Female wall plate for FT33

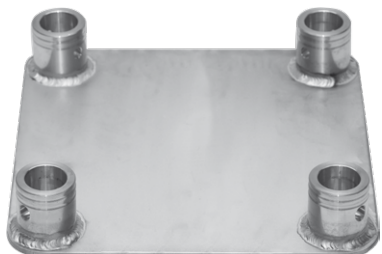

3004/F

Female base plate for FT34

3004/F/W

Female wall plate for FT34



3007

Male base plate for FT42

3007/W

Male wall plate for FT42



3008

Male base plate for FT43

3008/W

Male wall plate for FT43

ACCESSORIES FT31-TC45

QUICKLOCK LINE



4004

Male base plate for FT44

4004/W

Male wall plate for FT44



3007/F

Female base plate for FT42

3007/F/W

Female wall plate for FT42

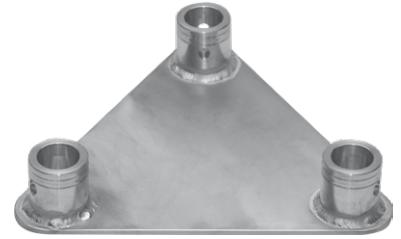

3008/F

Female base plate for FT43

3008/F/W

Female wall plate for FT43

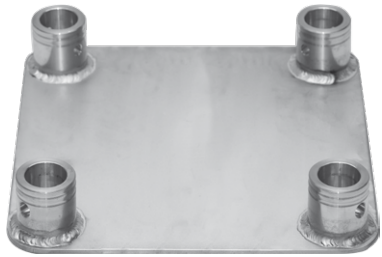

4004/F

Female base plate for FT44

4004/F/W

Female wall plate for FT44

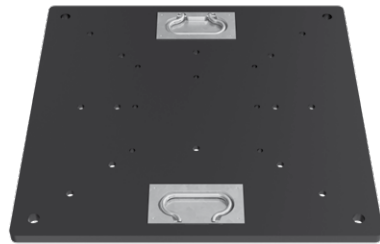

1000

Universal steel base plate;
black/zinc; 0.5 x 0.5 x 0.015 m
(1.64 x 1.64 x 0.05 ft);
FT31-TC45

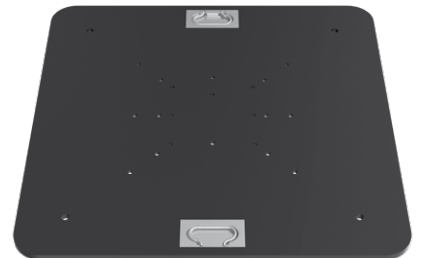

1001

Universal steel base plate;
black/zinc; 0.8 x 0.8 x 0.015 m
(2.62 x 2.62 x 0.05 ft);
FT31-TC45



3005

Universal aluminium base plate,
0.91 x 0.3 x 0.005 m (2.98 x 0.98
x 0.016 ft); FT23, FT24, FT33,
HT33, FT34, HT34, TC35

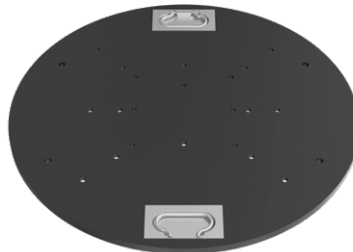

3006

Universal base plate; black/zinc;
Ø 0.65 x 0.015 m (2.13 x 0.05 ft);
FT33, HT33, FT34, HT34, FT44,
HT44, TC35, TC45

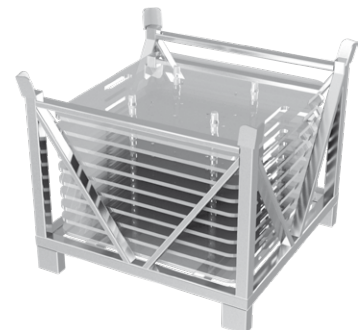

1002

Dolly for base plates
800 x 800 mm (31.49 x 31.49 ft)

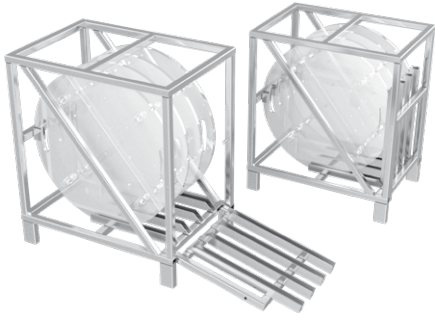

1003

Dolly for circle base plates
Ø 650 mm (25.59 in)

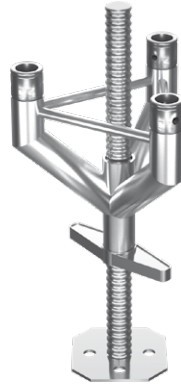

FT33-BLF

Levelling base
1.6 kg (3.53 lbs)

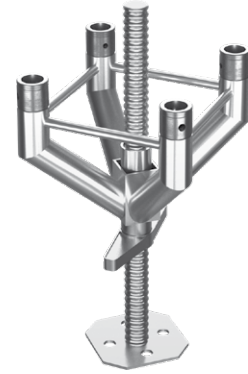

FT34-BLF

Levelling base
2.4 kg (5.29 lbs)

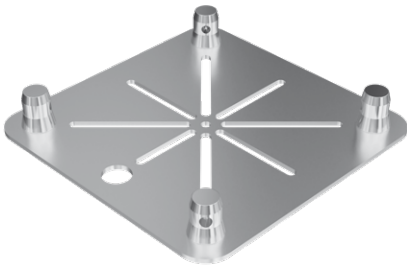

3004-L

FT34 Base plate for lights
1.44 kg (3.18 lbs)

SPECIFICATIONS

Tubes	50 x 2 mm (1.97 x 0.08 in)
Alloy	EN AW-6082 T6

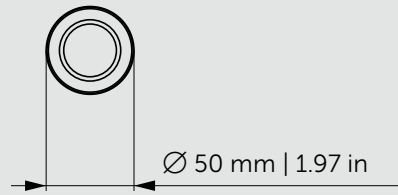

LOADING TABLES

		1 m	2 m	3 m
UDL [kg/m]		287	72	32
Deflection [mm]		6	24	54
CPL [kg]		144	72	47
Deflection [mm]		5	19	44
		3.28 ft	6.56 ft	9.84 ft
UDL [lbs/ft]		192.86	48.38	21.50
Deflection [in]		0.24	0.94	2.13
CPL [lbs]		317.47	158.73	103.62
Deflection [in]		0.20	0.75	1.73

Loading tables are valid for static loads and spans with two supporting points.

Spans must be supported at each end.

Contact structural engineer if there are more supporting points applied or dynamic and wind loads involved.

STRAIGHT SEGMENT LENGTHS

Code	Length		Weight	
PT31-50	0.5 m	1.64 ft	0.79 kg	1.74 lbs
PT31-100	1.0 m	3.28 ft	1.20 kg	2.65 lbs
PT31-150	1.5 m	4.92 ft	1.61 kg	3.55 lbs
PT31-200	2.0 m	6.56 ft	2.02 kg	4.45 lbs
PT31-250	2.5 m	8.20 ft	2.43 kg	5.36 lbs
PT31-300	3.0 m	9.84 ft	2.84 kg	6.26 lbs
PT31-350	3.5 m	11.48 ft	3.25 kg	7.17 lbs
PT31-400	4.0 m	13.12 ft	3.66 kg	8.07 lbs
PT31-500	5.0 m	14.76 ft	4.48 kg	9.88 lbs

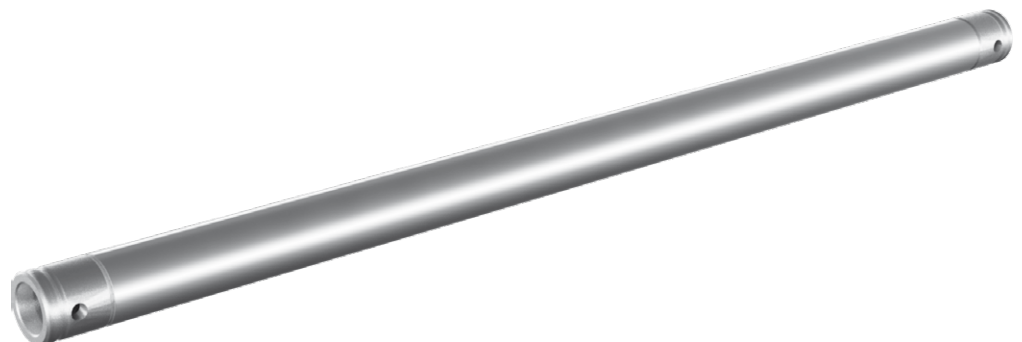

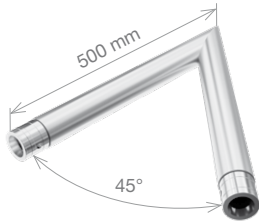

PT31-C19

2-way 45° corner
0.5 m (1.64 ft)
1.10 kg (2.43 lbs)

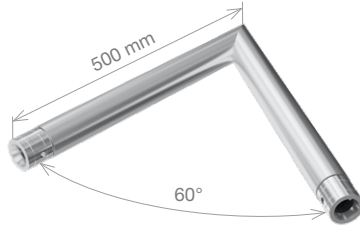

PT31-C20

2-way 60° corner
0.5 m (1.64 ft)
1.10 kg (2.43 lbs)

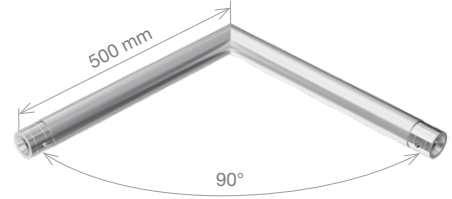

PT31-C21

2-way 90° corner
0.5 m (1.64 ft)
1.10 kg (2.43 lbs)

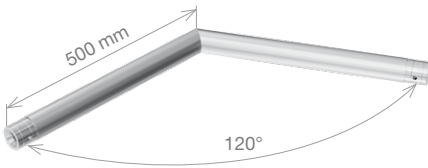

PT31-C22

2-way 120° corner
0.5 m (1.64 ft)
1.10 kg (2.43 lbs)

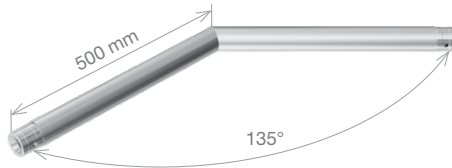

PT31-C23

2-way 135° corner
0.5 m (1.64 ft)
1.10 kg (2.43 lbs)

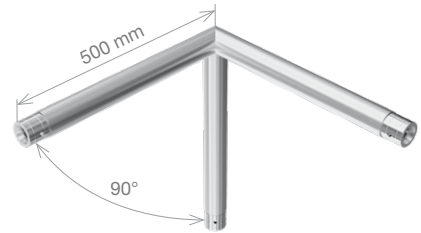

PT31-C30

3-way 90° corner
0.5 m (1.64 ft)
1.63 kg (3.59 lbs)

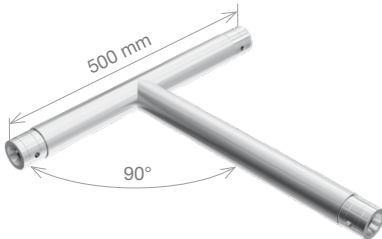

PT31-T35

3-way T-junction
0.5 m (1.64 ft)
1.22 kg (2.69 lbs)

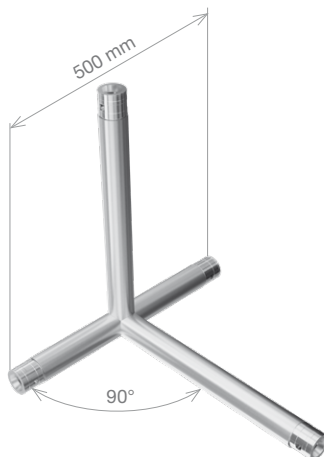

PT31-T42

4-way T-junction
0.5 m (1.64 ft)
1.93 kg (4.25 lbs)

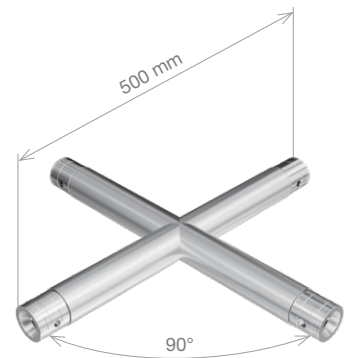

PT31-C41

4-way cross junction
0.5 m (1.64 ft)
1.37 kg (3.03 lbs)

SPECIFICATIONS

Tubes	50 x 2 mm (1.97 x 0.08 in)
Braces	16 x 2 mm (0.63 x 0.08 in)
Alloy	EN AW-6082 T6

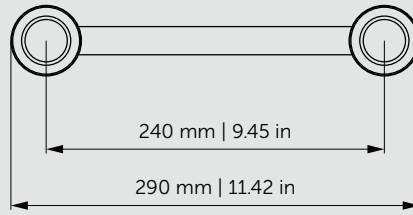

LOADING TABLES

		2 m	4 m	6 m	8 m	10 m	12 m
UDL [kg/m]		479	238	107	59	37	25
Deflection [mm]		2	13	29	52	82	118
CPL [kg]		943	487	320	235	183	148
Deflection [mm]		2	10	24	42	67	97
		6.56 ft	13.12 ft	19.69 ft	26.25 ft	32.81 ft	39.37 ft
UDL [lbs/ft]		321.87	159.93	71.90	39.65	24.86	16.80
Deflection [in]		0.08	0.51	1.14	2.05	3.23	4.65
CPL [lbs]		2078.96	1073.65	705.48	518.09	403.45	326.28
Deflection [in]		0.08	0.39	0.94	1.65	2.64	3.82

Loading tables are valid for static loads and spans with two supporting points.

Spans must be supported at each end.

Contact structural engineer if there are more supporting points applied or dynamic and wind loads involved.

STRAIGHT SEGMENT LENGTHS

Code	Length		Weight	
PT32-50	0.5 m	1.64 ft	1.75 kg	3.85 lbs
PT32-100	1.0 m	3.28 ft	2.71 kg	5.97 lbs
PT32-150	1.5 m	4.92 ft	3.67 kg	8.09 lbs
PT32-200	2.0 m	6.56 ft	4.63 kg	10.21 lbs
PT32-250	2.5 m	8.20 ft	5.59 kg	12.32 lbs
PT32-300	3.0 m	9.84 ft	6.51 kg	14.36 lbs
PT32-350	3.5 m	11.48 ft	7.51 kg	16.56 lbs
PT32-400	4.0 m	13.12 ft	8.47 kg	18.67 lbs
PT32-500	5.0 m	14.76 ft	10.39 kg	22.91 lbs

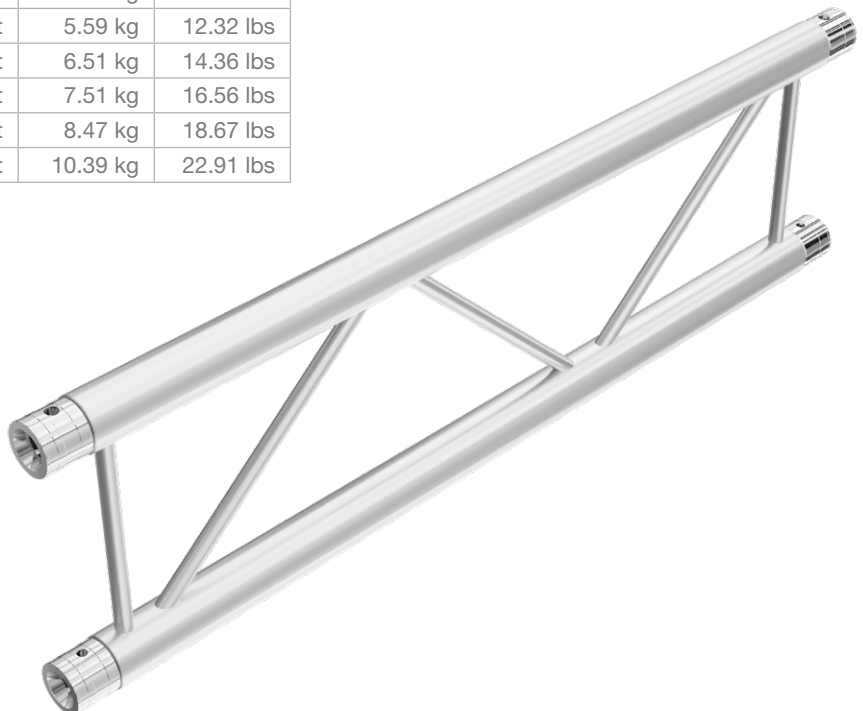

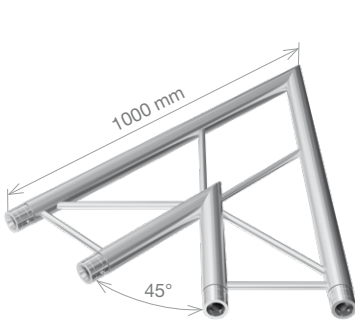

PT32-C19H

2-way 45° horizontal corner
1 m (3.28 ft)
3.45 kg (7.61 lbs)

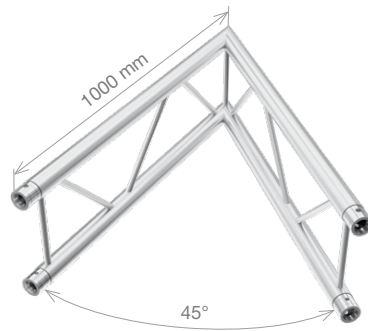

PT32-C19V

2-way 45° vertical corner
1 m (3.28 ft)
4.59 kg (10.11 lbs)

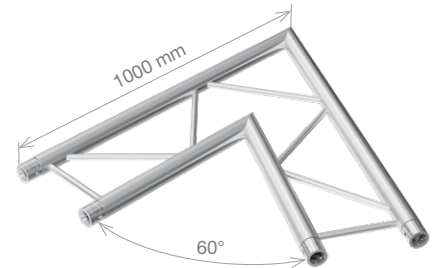

PT32-C20H

2-way 60° horizontal corner
1 m (3.28 ft)
3.80 kg (8.37 lbs)

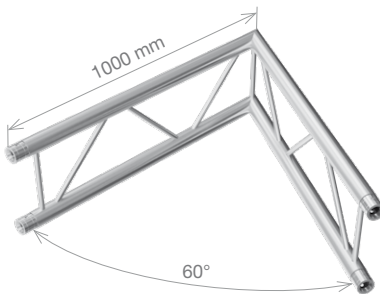

PT32-C20V

2-way 60° vertical corner
1 m (3.28 ft)
4.59 kg (10.11 lbs)

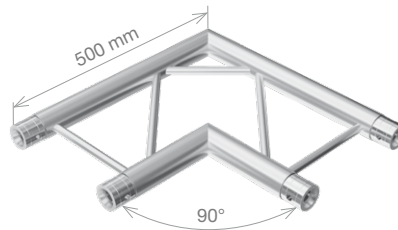

PT32-C21H

2-way 90° horizontal corner
0.5 m (1.64 ft)
2.27 kg (5.01 lbs)

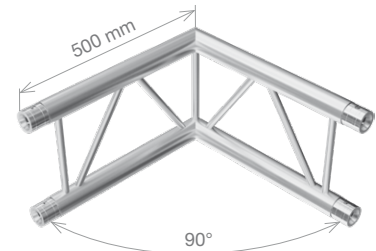

PT32-C21V

2-way 90° vertical corner
0.5 m (1.64 ft)
2.77 kg (6.11 lbs)

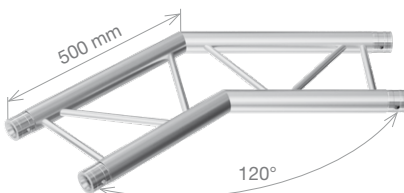

PT32-C22H

2-way 120° horizontal corner
0.5 m (1.64 ft)
2.50 kg (5.51 lbs)

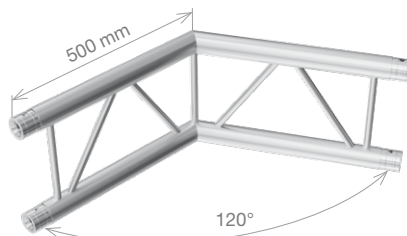

PT32-C22V

2-way 120° vertical corner
0.5 m (1.64 ft)
2.77 kg (6.11 lbs)

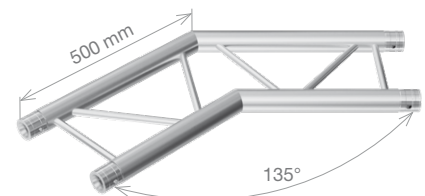

PT32-C23H



2-way 135° horizontal corner
0.5 m (1.64 ft)
2.56 kg (5.65 lbs)

PT32

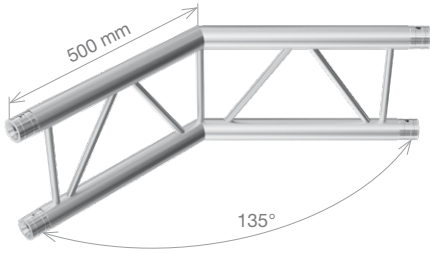
QUICKLOCK LINE





PT32-C23V

 2-way 135° vertical corner
 0.5 m (1.64 ft)
 2.77 kg (6.11 lbs)



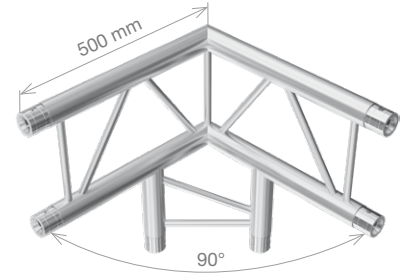

PT32-C30H

 3-way 90° horizontal corner
 0.5 m (1.64 ft)
 3.52 kg (7.77 lbs)



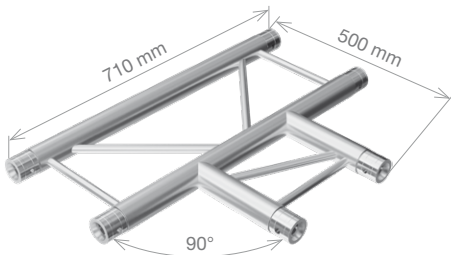

PT32-C30V

 3-way 90° vertical corner
 0.5 m (1.64 ft)
 3.61 kg (7.96 lbs)



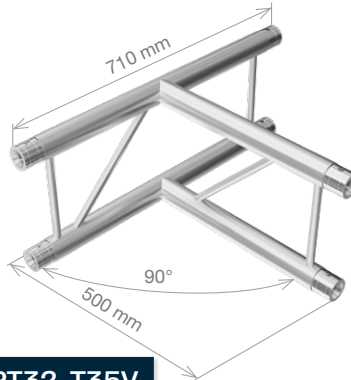

PT32-T35H

 3-way horizontal T-junction
 0.71 x 0.5 m (2.33 x 1.64 ft)
 2.99 kg (6.59 lbs)



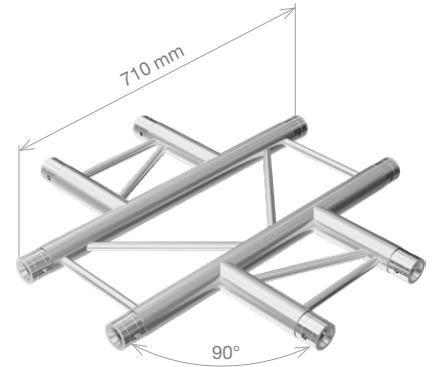

PT32-T35V

 3-way vertical T-junction
 0.71 x 0.5 m (2.33 x 1.64 ft)
 3.40 kg (7.50 lbs)



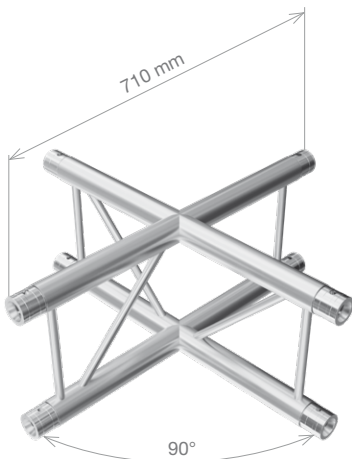

PT32-C41H

 4-way horizontal cross junction
 0.71 m (2.33 ft)
 3.83 kg (8.44 lbs)



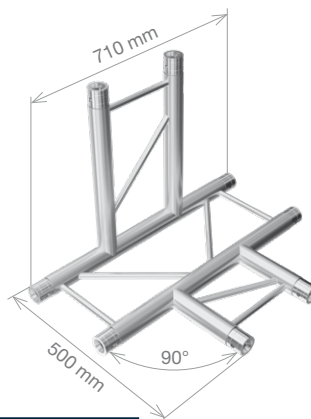

PT32-C41V

 4-way vertical cross junction
 0.71 m (2.33 ft)
 4.26 kg (9.39 lbs)



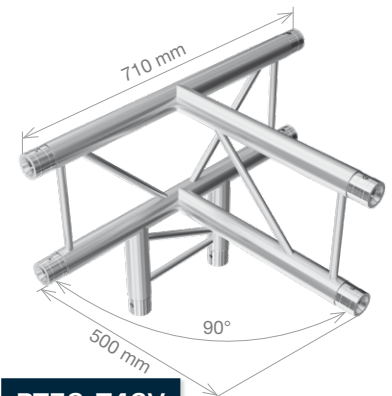

PT32-T42H

 4-way horizontal T-junction
 0.71 x 0.5 m (2.33 x 1.64 ft)
 4.24 kg (9.35 lbs)



PT32-T42V

 4-way vertical T-junction
 0.71 x 0.5 m (2.33 x 1.64 ft)
 4.24 kg (9.35 lbs)

CORNERS

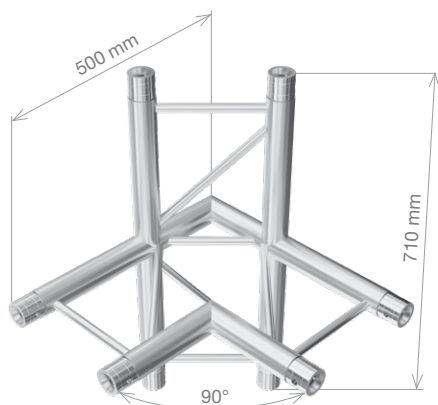

PT32-T44H

4-way 90° horizontal corner
 0.5 x 0.5 x 0.71 m
 (1.64 x 1.64 x 2.33 ft)
 4.38 kg (9.66 lbs)

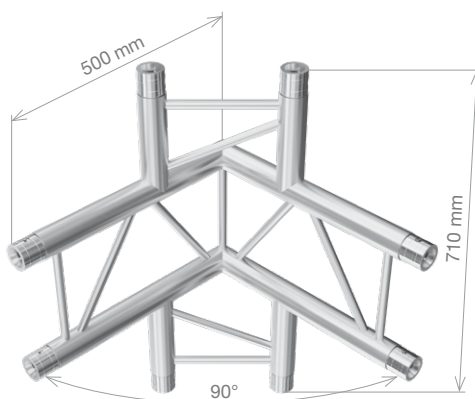

PT32-T44V

4-way 90° vertical corner
 0.5 x 0.5 x 0.71 m
 (1.64 x 1.64 x 2.33 ft)
 4.45 kg (9.81 lbs)

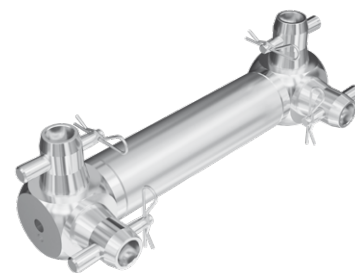

PT32-31-AD

Adapter for PT32-PT31 connection
 0.29 m (0.95 ft)
 0.68 kg (1.50 lbs)

Includes connection sets for two ways.

CIRCLES

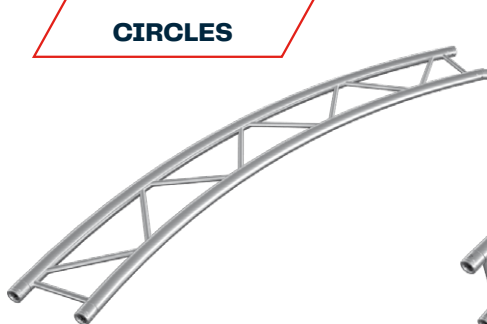

PT32-CH

Horizontal circle,
 various diameters

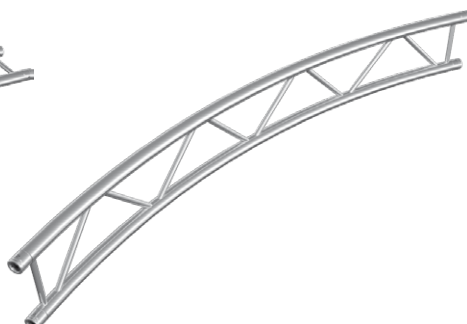

PT32-CV

Vertical circle,
 various diameters

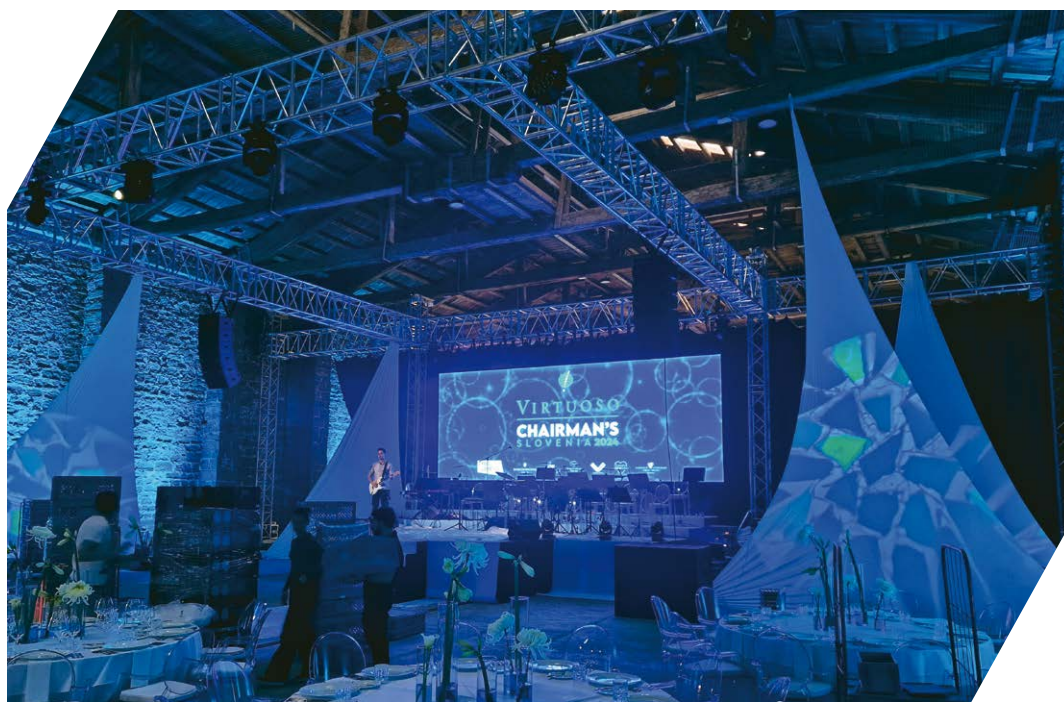

SPECIFICATIONS

Tubes	50 x 2 mm (1.97 x 0.08 in)
Braces	16 x 2 mm (0.63 x 0.08 in)
Alloy	EN AW-6082 T6

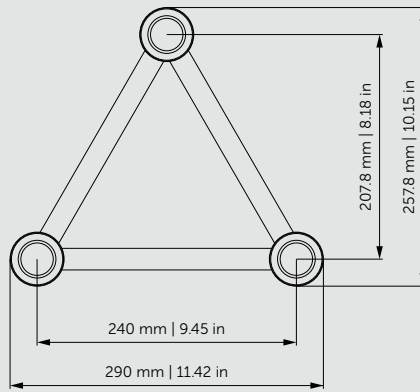

LOADING TABLES

		2 m	4 m	6 m	8 m	10 m	12 m
UDL [kg/m]		680	206	97	54	33	20
Deflection [mm]		2.3	11.5	28.1	51	78.3	107.2
CPL [kg]		761	413	292	217	163	133
Deflection [mm]		2.1	9.3	22.7	41.5	64.3	96
		6.56 ft	13.12 ft	19.68 ft	26.24 ft	32.81 ft	39.37 ft
UDL [lbs/ft]		457	138.4	65.2	36.3	22.2	13.4
Deflection [in]		0.1	0.5	1.1	2	3.1	4.2
CPL [lbs]		1678	910.7	643.9	478.5	359.4	293.3
Deflection [in]		0.1	0.4	0.9	1.6	2.5	3.8

Loading tables are valid for static loads and spans with two supporting points.

Spans must be supported at each end.

Contact structural engineer if there are more supporting points applied or dynamic and wind loads involved.

STRAIGHT SEGMENT LENGTHS

Code	Length		Weight	
PT33-50	0.5 m	1.64 ft	2.87 kg	6.32 lbs
PT33-100	1 m	3.28 ft	4.53 kg	9.99 lbs
PT33-150	1.5 m	4.92 ft	6.18 kg	13.62 lbs
PT33-200	2 m	6.56 ft	7.83 kg	17.26 lbs
PT33-250	2.5 m	8.2 ft	9.48 kg	20.90 lbs
PT33-300	3 m	9.84 ft	11.13 kg	24.54 lbs
PT33-350	3.5 m	11.48 ft	12.78 kg	28.18 lbs
PT33-400	4 m	13.12 ft	14.43 kg	31.81 lbs
PT33-450	4.5 m	14.76 ft	16.08 kg	35.45 lbs
PT33-500	5 m	16.40 ft	17.73 kg	39.09 lbs

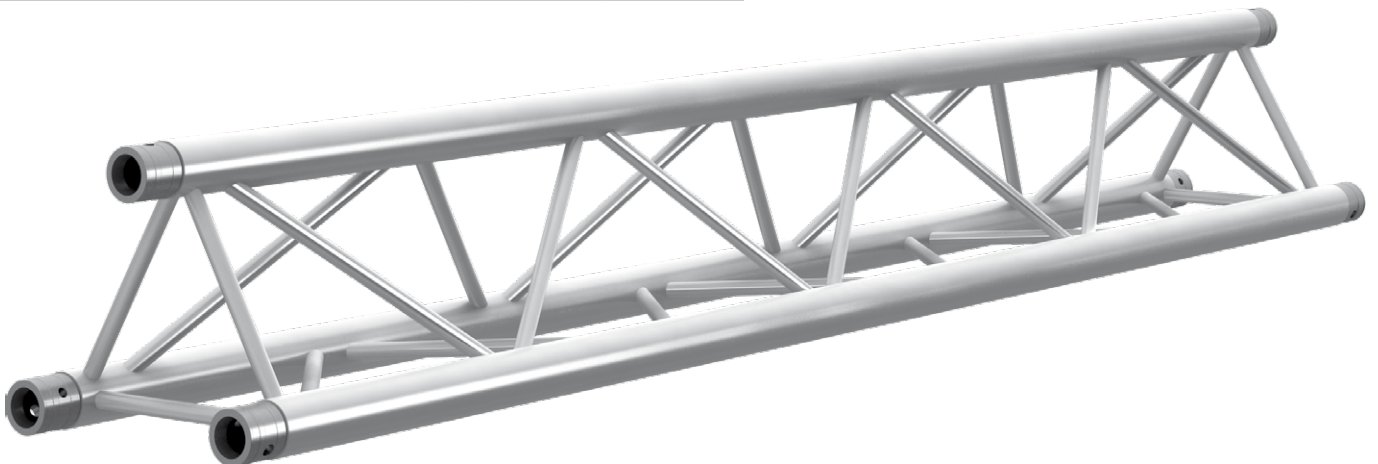

SPECIFICATIONS

Tubes	48 x 3 mm (1.89 x 0.12 in)
Braces	16 x 2 mm (0.63 x 0.08 in)
Alloy	EN AW-6082 T6

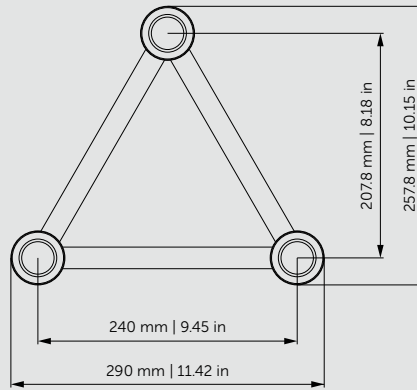

LOADING TABLES

		2 m	4 m	6 m	8 m	10 m	12 m
UDL [kg/m]		713	349	152	81	50	30
Deflection [mm]		1.8	13.9	31.4	54.9	86.8	117.2
CPL [kg]		913	552	456	324	249	180
Deflection [mm]		6.1	17.5	25.4	44.8	71.6	98.2
		6.56 ft	13.12 ft	19.69 ft	26.25 ft	32.81 ft	39.37 ft
UDL [lbs/ft]		479.11	234.52	102.14	54.43	33.60	20.16
Deflection [in]		0.07	0.55	1.24	2.16	3.42	4.61
CPL [lbs]		2012.82	1216.95	1005.31	714.30	548.95	396.83
Deflection [in]		0.24	0.69	1.00	1.76	2.82	3.87

Loading tables are valid for static loads and spans with two supporting points.

Spans must be supported at each end.

Contact structural engineer if there are more supporting points applied or dynamic and wind loads involved.

STRAIGHT SEGMENT LENGTHS

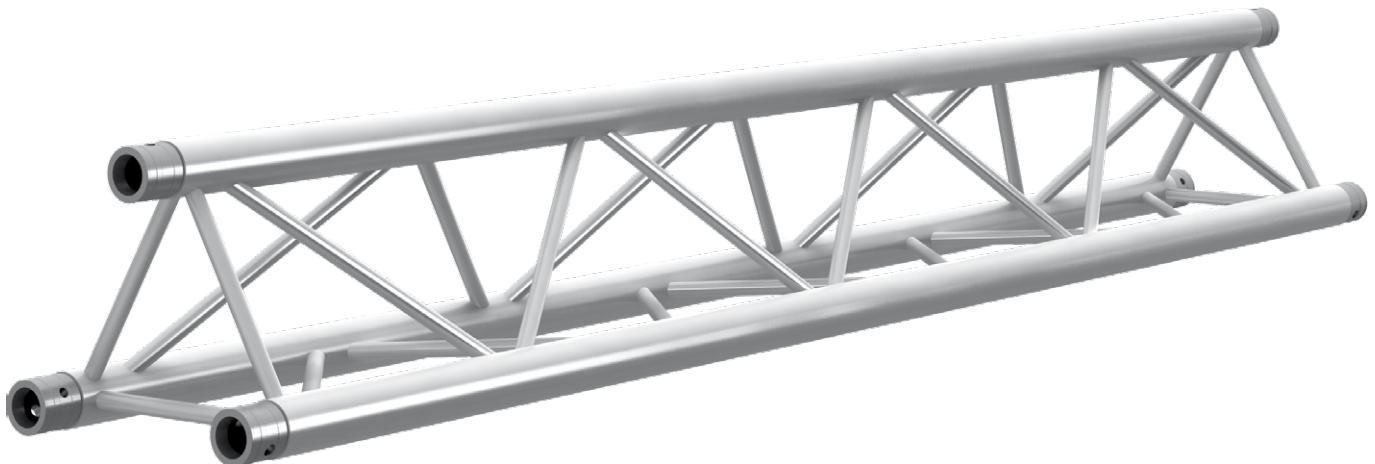

Code	Length		Weight	
PTH33-50	0.5 m	1.64 ft	3.49 kg	7.69 lbs
PTH33-100	1 m	3.28 ft	5.64 kg	12.44 lbs
PTH33-150	1.5 m	4.92 ft	7.75 kg	17.09 lbs
PTH33-200	2 m	6.56 ft	9.93 kg	21.90 lbs
PTH33-250	2.5 m	8.20 ft	12.08 kg	26.63 lbs
PTH33-300	3 m	9.84 ft	14.22 kg	31.36 lbs
PTH33-350	3.5 m	11.48 ft	16.37 kg	36.09 lbs
PTH33-400	4 m	13.12 ft	18.51 kg	40.81 lbs
PTH33-500	5 m	16.40 ft	22.80 kg	50.27 lbs





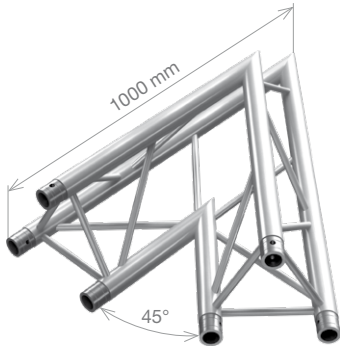

PT33 / PTH33

QUICKLOCK LINE

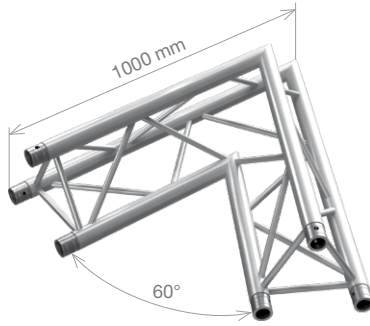



PT33-C19	PTH33-C19
 2-way 45° corner	
 1 m (3.28 ft)	
 7.31 kg (16.12 lbs)	7.25 kg (15.99 lbs)



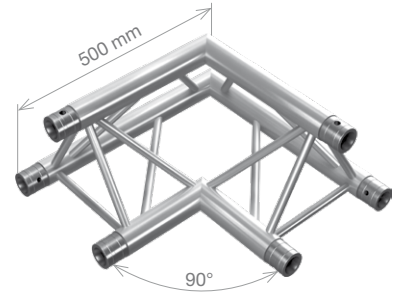

PT33-C20	PTH33-C20
 2-way 60° corner	
 1 m (3.28 ft)	
 6.34 kg (13.98 lbs)	8.03 kg (17.70 lbs)



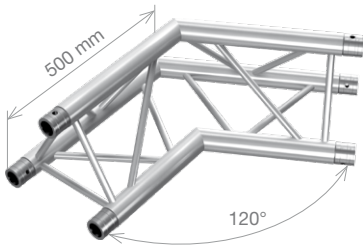

PT33-C21	PTH33-C21
 2-way 90° corner	
 0.5 m (1.64 ft)	
 3.77 kg (8.31 lbs)	4.64 kg (10.23 lbs)



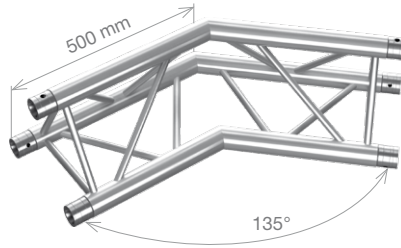

PT33-C22	PTH33-C22
 2-way 120° corner	
 0.5 m (1.64 ft)	
 4.14 kg (9.12 lbs)	5.11 kg (11.26 lbs)



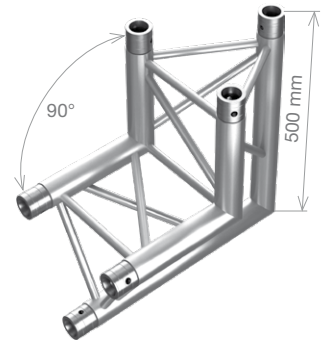

PT33-C23	PTH33-C23
 2-way 135° corner	
 0.5 m (1.64 ft)	
 4.23 kg (9.33 lbs)	5.24 kg (11.56 lbs)



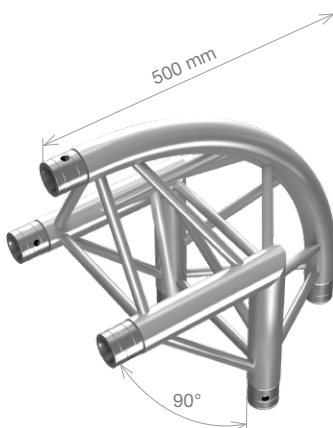

PT33-C24	PTH33-C24
 2-way 90° corner, apex out	
 0.5 m (1.64 ft)	
 3.61 kg (7.96 lbs)	4.45 kg (9.81 lbs)



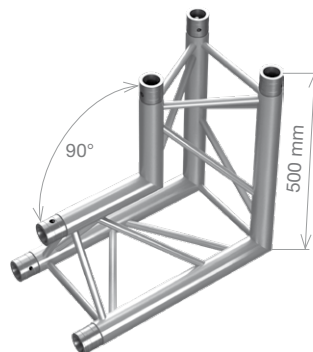

PT33-C24-R	
 2-way 90° rounded corner, apex out	
 0.5 m (1.64 ft)	
 3.44 kg (7.59 lbs)	

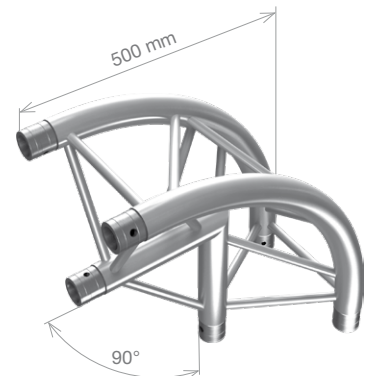

PT33-C25	PTH33-C25
 2-way 90° corner, apex in	
 0.5 m (1.64 ft)	
 4.07 kg (8.96 lbs)	5.04 kg (11.11 lbs)



PT33-C25-R	
 2-way 90° rounded corner, apex in	
 0.5 m (1.64 ft)	
 3.45 kg (7.61 lbs)	

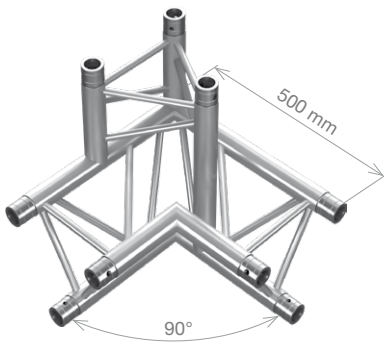

PT33-C31	PTH33-C31
3-way 90° right corner, apex up	
0.5 m (1.64 ft)	
5.43 kg (11.96 lbs)	6.68 kg (14.72 lbs)

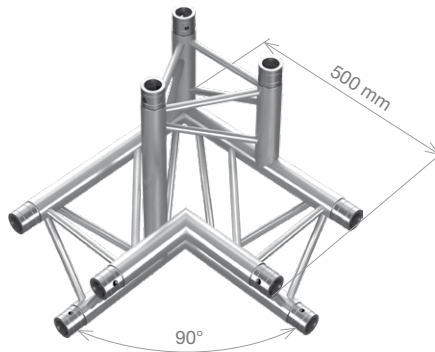

PT33-C32	PTH33-C32
3-way 90° left corner, apex up	
0.5 m (1.64 ft)	
5.43 kg (11.96 lbs)	6.68 kg (14.72 lbs)

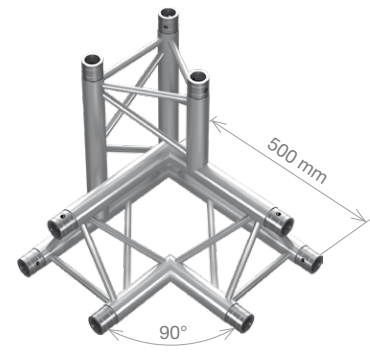

PT33-C33	PTH33-C33
3-way 90° right corner, apex down	
0.5 m (1.64 ft)	
5.67 kg (12.51 lbs)	6.99 kg (15.42 lbs)

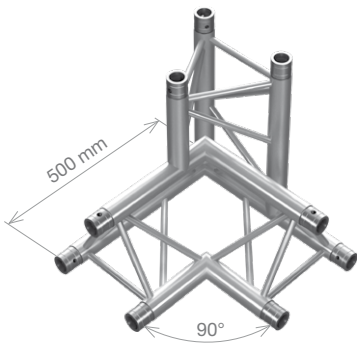

PT33-C34	PTH33-C34
3-way 90° left corner, apex down	
0.5 m (1.64 ft)	
5.67 kg (12.51 lbs)	6.99 kg (15.42 lbs)

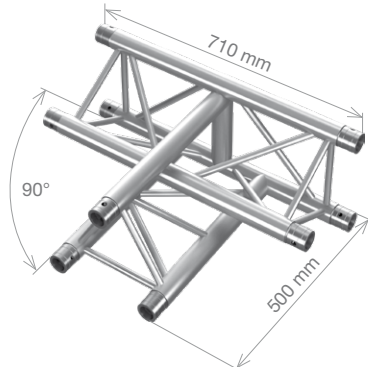

PT33-T35	PTH33-T35
3-way vertical T-junction, apex down	
0.71 x 0.5 m (2.33 x 1.64 ft)	
5.82 kg (12.82 lbs)	7.23 kg (15.93 lbs)

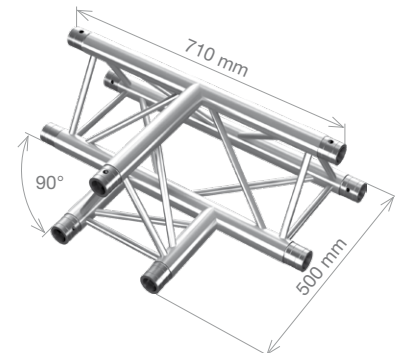

PT33-T36	PTH33-T36
3-way horizontal T-junction	
0.71 x 0.5 m (2.33 x 1.64 ft)	
5.07 kg (11.18 lbs)	6.22 kg (13.70 lbs)

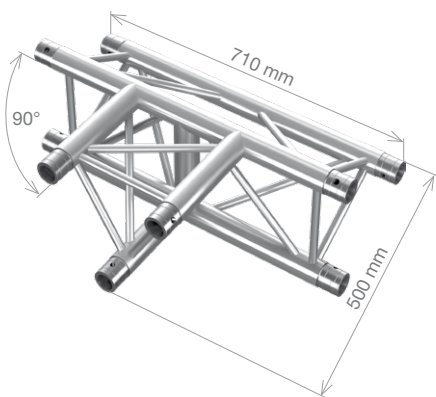

PT33-T37	PTH33-T37
3-way horizontal T-junction, apex up	
0.71 x 0.5 m (2.33 x 1.64 ft)	
5.25 kg (11.57 lbs)	6.45 kg (14.23 lbs)

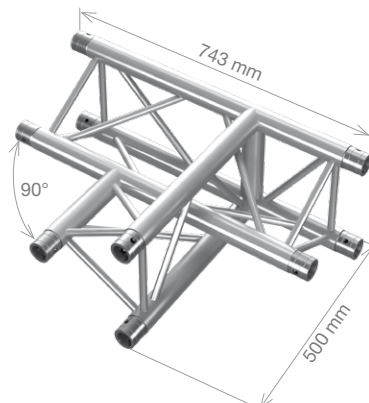

PT33-T38	PTH33-T38
3-way vertical T-junction, apex down	
0.74 x 0.5 m (2.44 x 1.64 ft)	
5.73 kg (12.63 lbs)	7.10 kg (15.66 lbs)

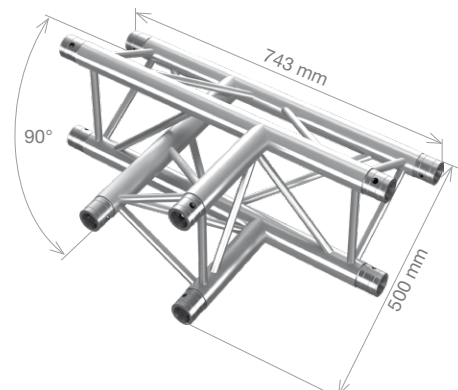

PT33-T39	PTH33-T39
3-way vertical T-junction	
0.74 x 0.5 m (2.44 x 1.64 ft)	
5.33 kg (11.74 lbs)	6.56 kg (14.47 lbs)

PT33 / PTH33

QUICKLOCK LINE

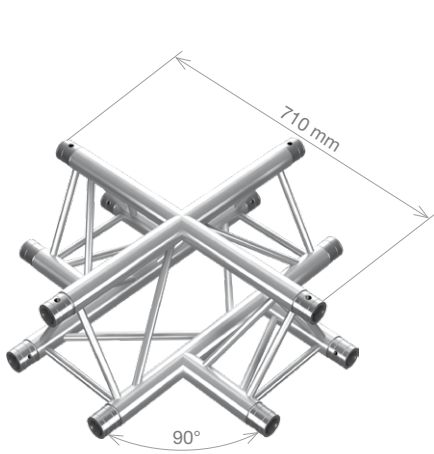

PT33-C41		PTH33-C41	
	4-way cross junction		
	0.71 x 0.71 m (2.33 x 2.33 ft)		
	6.58 kg (14.50 lbs)	8.04 kg (17.72 lbs)	

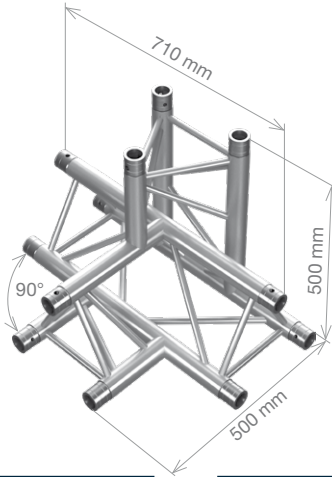

PT33-T42		PTH33-T42	
	4-way T-junction, apex down		
	0.71 x 0.5 x 0.5 m (2.33 x 1.64 x 1.64 ft)		
	6.98 kg (15.38 lbs)	8.57 kg (18.89 lbs)	

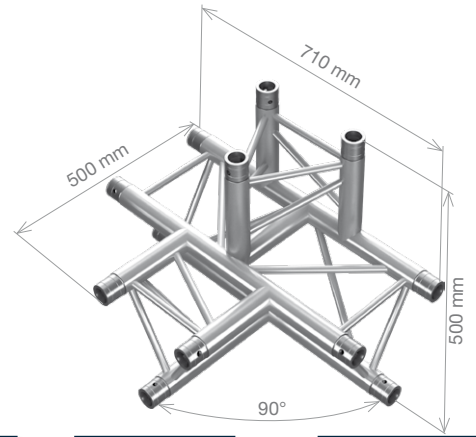

PT33-T43		PTH33-T43	
	4-way T-junction, apex up		
	0.71 x 0.5 x 0.5 m (2.33 x 1.64 x 1.64 ft)		
	6.73 kg (14.84 lbs)	8.26 kg (18.20 lbs)	

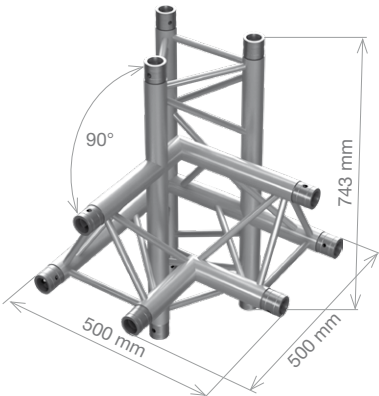

PT33-C44		PTH33-C44	
	4-way 90° right corner		
	0.74 x 0.5 x 0.5 m (2.44 x 1.64 x 1.64 ft)		
	7.33 kg (16.16 lbs)	8.37 kg (18.45 lbs)	

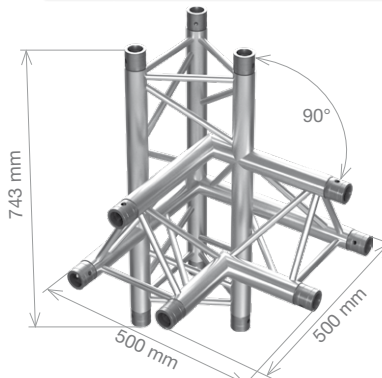

PT33-C45		PTH33-C45	
	4-way 90° left corner		
	0.74 x 0.5 x 0.5 m (2.44 x 1.64 x 1.64 ft)		
	7.33 kg (16.16 lbs)	8.37 kg (18.45 lbs)	

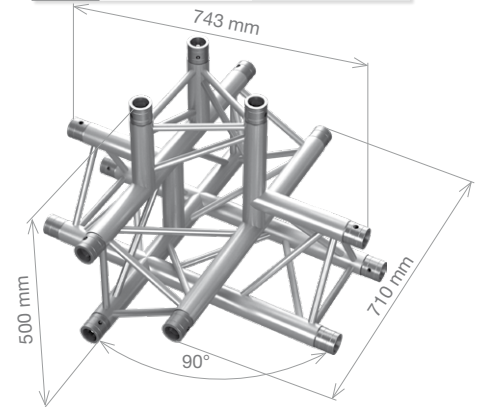

PT33-T51		PTH33-T51	
	5-way T-junction, apex down		
	0.74 x 0.71 x 0.5 m (2.44 x 2.33 x 1.64 ft)		
	8.64 kg (19.04 lbs)	9.99 kg (22.03 lbs)	

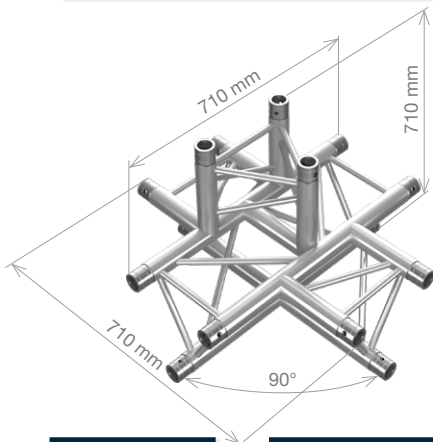

PT33-C52		PTH33-C52	
	5-way cross junction, apex up		
	0.71 x 0.71 x 0.5 m (2.33 x 2.33 x 1.64 ft)		
	8.23 kg (18.15 lbs)	10.08 kg (22.22 lbs)	

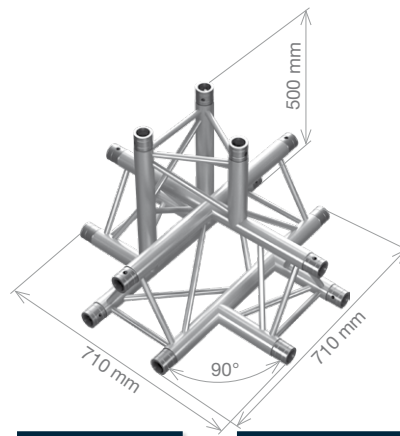

PT33-C53		PTH33-C53	
	5-way cross junction, apex down		
	0.71 x 0.71 x 0.5 m (2.33 x 2.33 x 1.64 ft)		
	8.48 kg (18.70 lbs)	10.39 kg (22.90 lbs)	



PT33-C1

Circle, apex up/down,
various diameters



PTH33-C1

PT33-C2

Circle, apex in,
various diameters

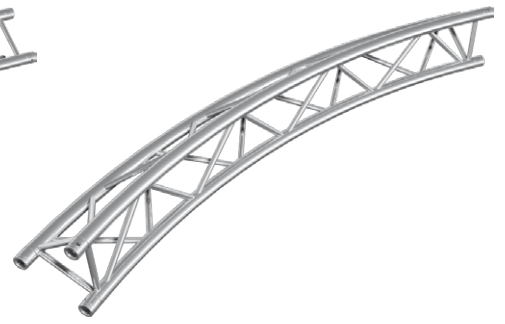

PT33-C3

Circle, apex out,
various diameters

PTH33-C3

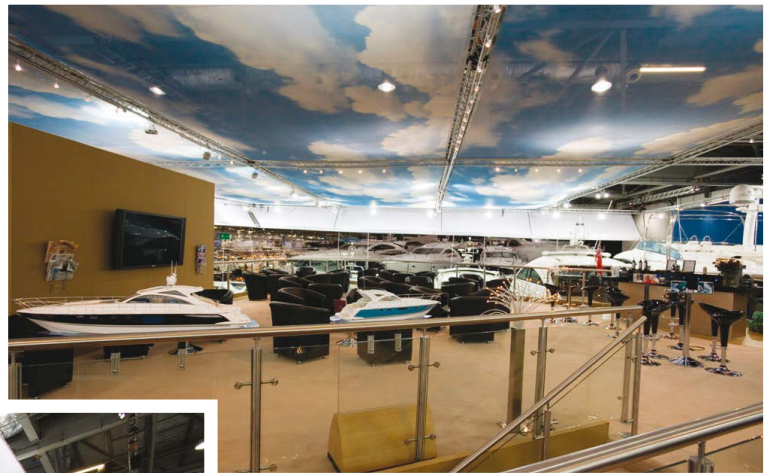

SPECIFICATIONS

Tubes	50 x 2 mm (1.97 x 0.08 in)
Braces	16 x 2 mm (0.63 x 0.08 in)
Alloy	EN AW-6082 T6

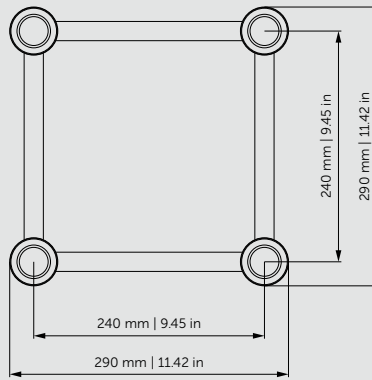

LOADING TABLES

		2 m	4 m	6 m	8 m	10 m	12 m
UDL [kg/m]		785	390	229	130	81	53
Deflection [mm]		1.4	10.8	32.5	59.3	92.5	130.3
CPL [kg]		1570	961	688	520	406	321
Deflection [mm]		2.2	10.7	26.2	47.9	75.1	106.6
		6.56 ft	13.12 ft	19.68 ft	26.24 ft	32.81 ft	39.37 ft
UDL [lbs/ft]		527.6	262.1	153.9	87.4	54.4	35.6
Deflection [in]		0.1	0.4	1.3	2.3	3.6	5.1
CPL [lbs]		3461.9	2119	1517	1146.6	895.2	707.8
Deflection [in]		0.1	0.4	1	1.9	3	4.2

Loading tables are valid for static loads and spans with two supporting points.

Spans must be supported at each end.

Contact structural engineer if there are more supporting points applied or dynamic and wind loads involved.

STRAIGHT SEGMENT LENGTHS

Code	Length		Weight	
PT34-50	0.5 m	1.64 ft	3.96 kg	8.73 lbs
PT34-100	1 m	3.28 ft	6.18 kg	13.62 lbs
PT34-150	1.5 m	4.92 ft	8.38 kg	18.47 lbs
PT34-200	2 m	6.56 ft	10.58 kg	23.32 lbs
PT34-250	2.5 m	8.20 ft	12.78 kg	28.17 lbs
PT34-300	3 m	9.84 ft	14.98 kg	33.02 lbs
PT34-350	3.5 m	11.48 ft	17.18 kg	37.87 lbs
PT34-400	4 m	13.12 ft	19.38 kg	42.72 lbs
PT34-500	5 m	16.40 ft	23.64 kg	52.12 lbs

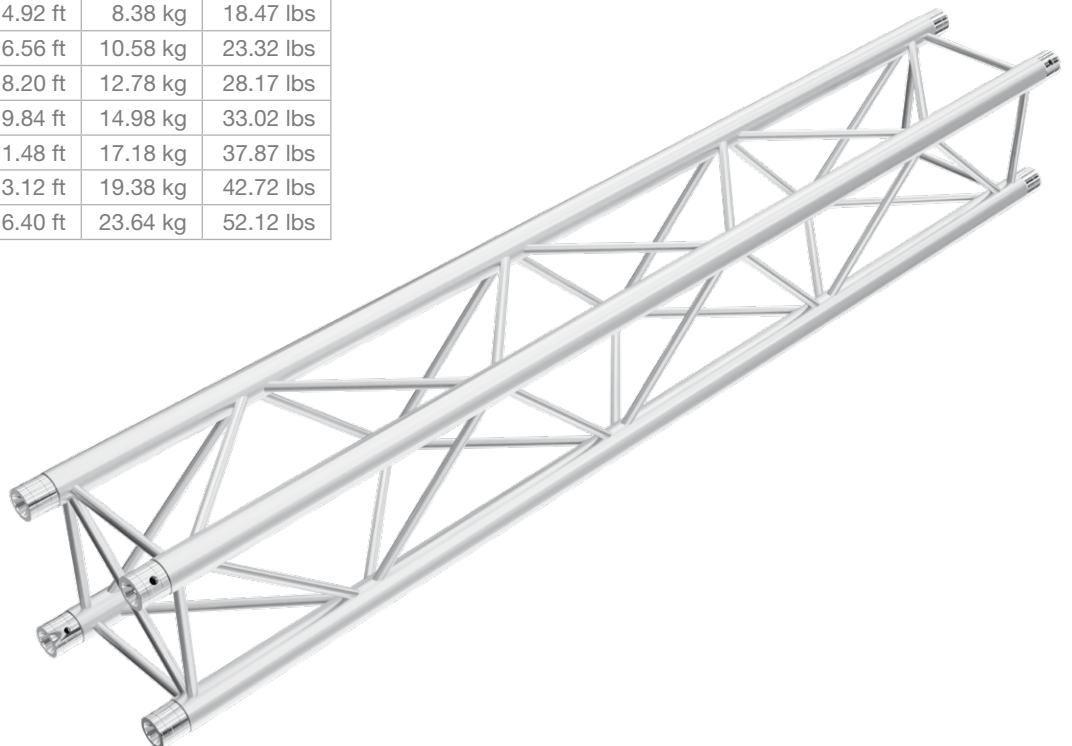

SPECIFICATIONS

Tubes	48 x 3 mm (1.89 x 0.12 in)
Braces	16 x 2 mm (0.63 x 0.08 in)
Alloy	EN AW-6082 T6

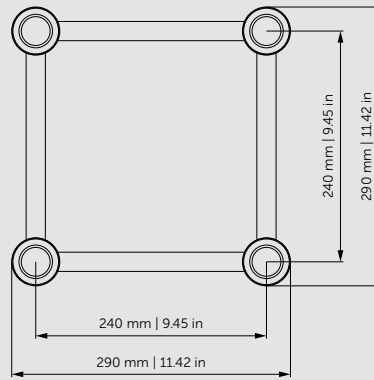

LOADING TABLES

		2 m	4 m	6 m	8 m	10 m	12 m
UDL [kg/m]		726	359	237	175	124	83
Deflection [mm]		0.9	7.2	24.2	57.5	101.1	144.9
CPL [kg]		1452	1436	1096	802	618	496
Deflection [mm]		1.4	11.4	29.7	52.8	82.2	118.8
		6.56 ft	13.12 ft	19.68 ft	26.24 ft	32.81 ft	39.37 ft
UDL [lbs/ft]		487.8	241.2	159.3	117.6	83.3	55.8
Deflection [in]		0.04	0.3	1.0	2.3	4.0	5.7
CPL [lbs]		3201.1	3165.8	2416.3	1768.1	1362.5	1093.5
Deflection [in]		0.1	0.5	1.2	2.1	3.2	4.7

Loading tables are valid for static loads and spans with two supporting points.

Spans must be supported at each end.

Contact structural engineer if there are more supporting points applied or dynamic and wind loads involved.

STRAIGHT SEGMENT LENGTHS

Code	Length		Weight	
PTH34-50	0.5 m	1.64 ft	4.79 kg	10.56 lbs
PTH34-100	1 m	3.28 ft	7.66 kg	16.90 lbs
PTH34-150	1.5 m	4.92 ft	10.48 kg	23.10 lbs
PTH34-200	2 m	6.56 ft	13.38 kg	29.51 lbs
PTH34-250	2.5 m	8.20 ft	16.24 kg	35.81 lbs
PTH34-300	3 m	9.84 ft	19.10 kg	42.12 lbs
PTH34-350	3.5 m	11.48 ft	21.96 kg	48.42 lbs
PTH34-400	4 m	13.12 ft	24.82 kg	54.73 lbs
PTH34-500	5 m	16.40 ft	30.54 kg	67.34 lbs

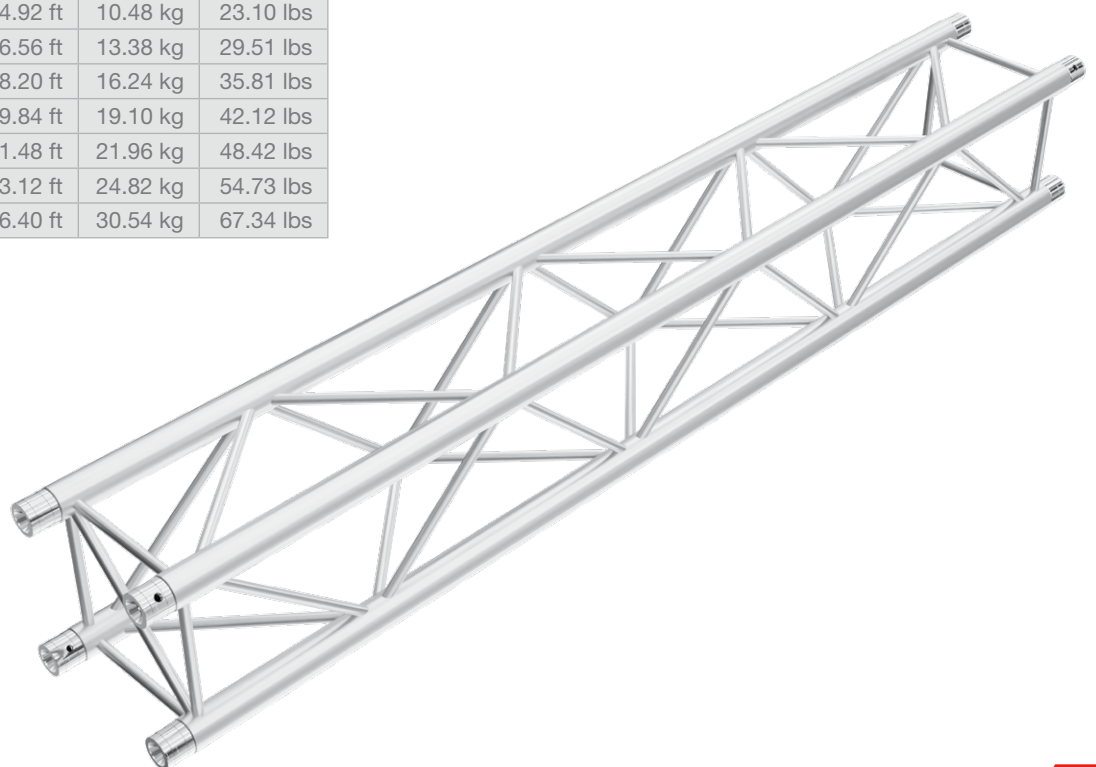

PT34 / PTH34

QUICKLOCK LINE

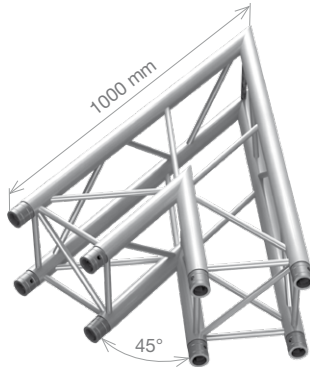

PT34-C19	PTH34-C19
2-way 45° corner	
1 m (3.28 ft)	
7.87 kg (17.34 lbs)	10.04 kg (22.13 lbs)

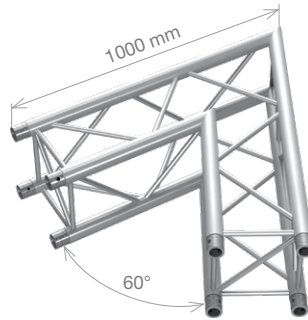

PT34-C20	PTH34-C20
2-way 60° corner	
1 m (3.28 ft)	
8.69 kg (19.15 lbs)	10.80 kg (23.81 lbs)

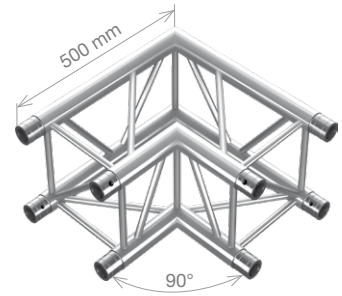

PT34-C21	PTH34-C21
2-way 90° corner	
0.5 m (1.64 ft)	
5.20 kg (11.46 lbs)	6.36 kg (14.03 lbs)

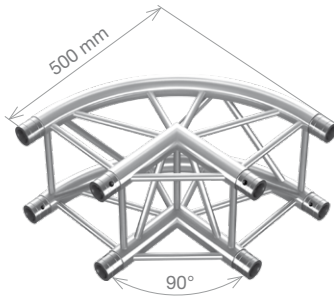

PT34-C21-R	
2-way 90° rounded corner	
0.5 m (1.64 ft)	
4.62 kg (10.19 lbs)	

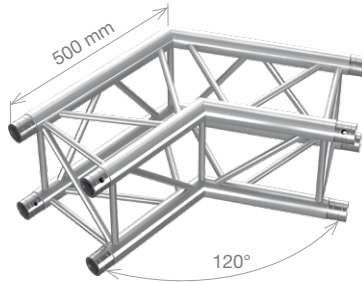

PT34-C22	PTH34-C22
2-way 120° corner	
0.5 m (1.64 ft)	
5.64 kg (12.43 lbs)	6.94 kg (15.29 lbs)

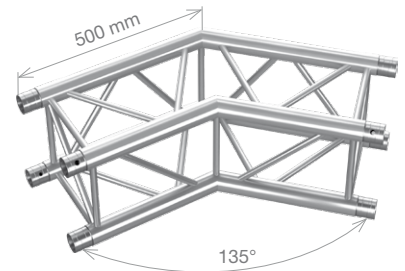

PT34-C23	PTH34-C23
2-way 135° corner	
0.5 m (1.64 ft)	
5.77 kg (12.72 lbs)	7.11 kg (15.68 lbs)

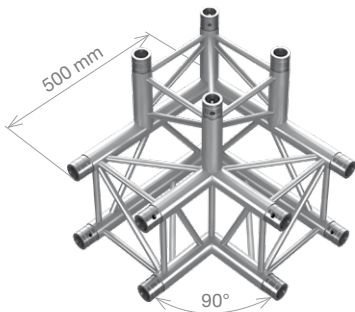

PT34-C30	PTH34-C30
3-way 90° corner	
0.5 m (1.64 ft)	
6.93 kg (15.28 lbs)	8.47 kg (18.66 lbs)

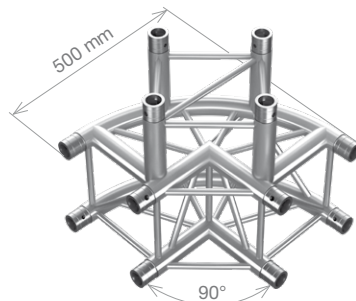

PT34-C30-R	
3-way 90° rounded corner	
0.5 m (1.64 ft)	
7.03 kg (15.50 lbs)	

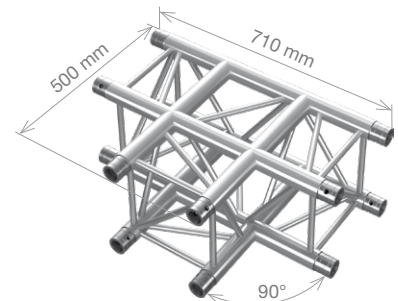

PT34-T35	PTH34-T35
3-way T-junction	
0.71 x 0.5 m (2.33 x 1.64 ft)	
7.77 kg (17.13 lbs)	7.56 kg (16.68 lbs)

CORNERS

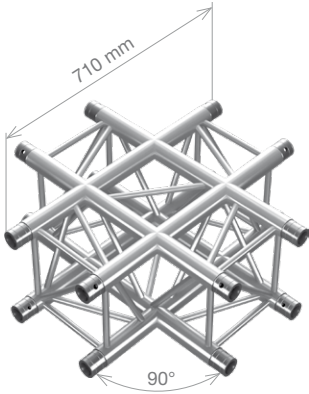

PT34-C41

PTH34-C41



4-way cross junction
0.71 x 0.71 m
(2.33 x 2.33 ft)



9.73 kg (21.44 lbs) 11.44 kg (25.23 lbs)

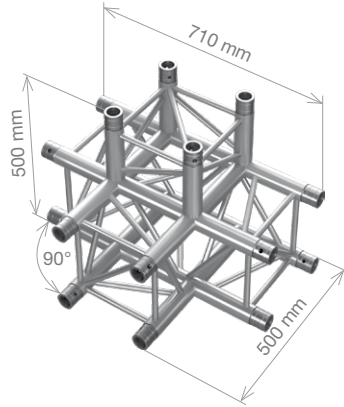

PT34-T42

PTH34-T42



4-way T-junction
0.71 x 0.5 x 0.5 m
(2.33 x 1.64 x 1.64 ft)



9.56 kg (21.07 lbs) 11.44 kg (25.23 lbs)

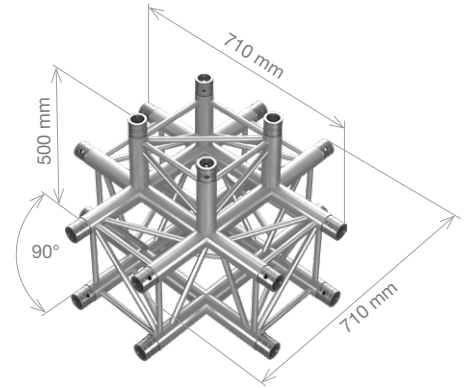

PT34-C55

PTH34-C55



5-way T-junction
0.71 x 0.5 x 0.5 m
(2.33 x 1.64 x 1.64 ft)



11.21 kg (24.71 lbs) 13.76 kg (30.34 lbs)

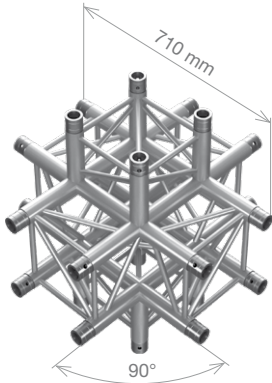

PT34-C60

PTH34-C60



6-way T-junction
0.71 x 0.71 x 0.71 m
(2.33 x 2.33 x 2.33 ft)



13.52 kg (29.81 lbs) 15.96 kg (35.19 lbs)



PT34-MCB

PTH34-MCB



Multi connection box
0.29 x 0.29 m (0.95 x 0.95 ft)



7.66 kg (16.89 lbs) 8.43 kg (18.59 lbs)

Includes connection sets for two ways.



SPECIFICATIONS

Tubes	50 x 2 mm (1.97 x 0.08 in)
Braces	20 x 2 mm (0.79 x 0.08 in)
Alloy	EN AW-6082 T6

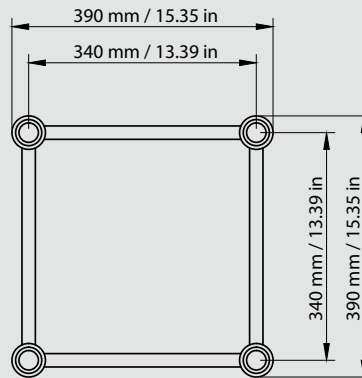

LOADING TABLES

		2 m	4 m	6 m	8 m	10 m	12 m
UDL [kg/m]		1045	519	344	204	130	89
Deflection [mm]		0.9	7.2	24.3	46.1	73.1	106.0
CPL [kg]		2090	1670	1090	814	649	531
Deflection [mm]		1.4	9.2	20.6	37.2	59.3	86.4
		6.56 ft	13.12 ft	19.68 ft	26.24 ft	32.81 ft	39.37 ft
UDL [lbs/ft]		702.2	348.8	231.2	137.1	87.4	59.8
Deflection [in]		0.04	0.3	1.0	1.8	2.9	4.2
CPL [lbs]		4607.7	3681.72	2403	1794.6	1430.8	1170.66
Deflection [in]		0.1	0.4	0.8	1.5	2.3	3.4

Loading tables are valid for static loads and spans with two supporting points. Spans must be supported at each end. Contact structural engineer if there are more supporting points applied or dynamic and wind loads involved. High values of distributed loads are idealized. Loads must be applied to knot points!

STRAIGHT SEGMENT LENGTHS

Code	Length		Weight	
PT44-50	0.5 m	1.64 ft	4.68 kg	10.31 lbs
PT44-100	1 m	3.28 ft	7.25 kg	15.98 lbs
PT44-150	1.5 m	4.92 ft	9.55 kg	21.06 lbs
PT44-200	2 m	6.56 ft	11.85 kg	26.12 lbs
PT44-250	2.5 m	8.20 ft	14.40 kg	31.74 lbs
PT44-300	3 m	9.84 ft	16.67 kg	36.76 lbs
PT44-350	3.5 m	11.48 ft	19.24 kg	42.42 lbs
PT44-400	4 m	13.12 ft	21.57 kg	47.54 lbs
PT44-500	5 m	16.40 ft	26.43 kg	58.26 lbs

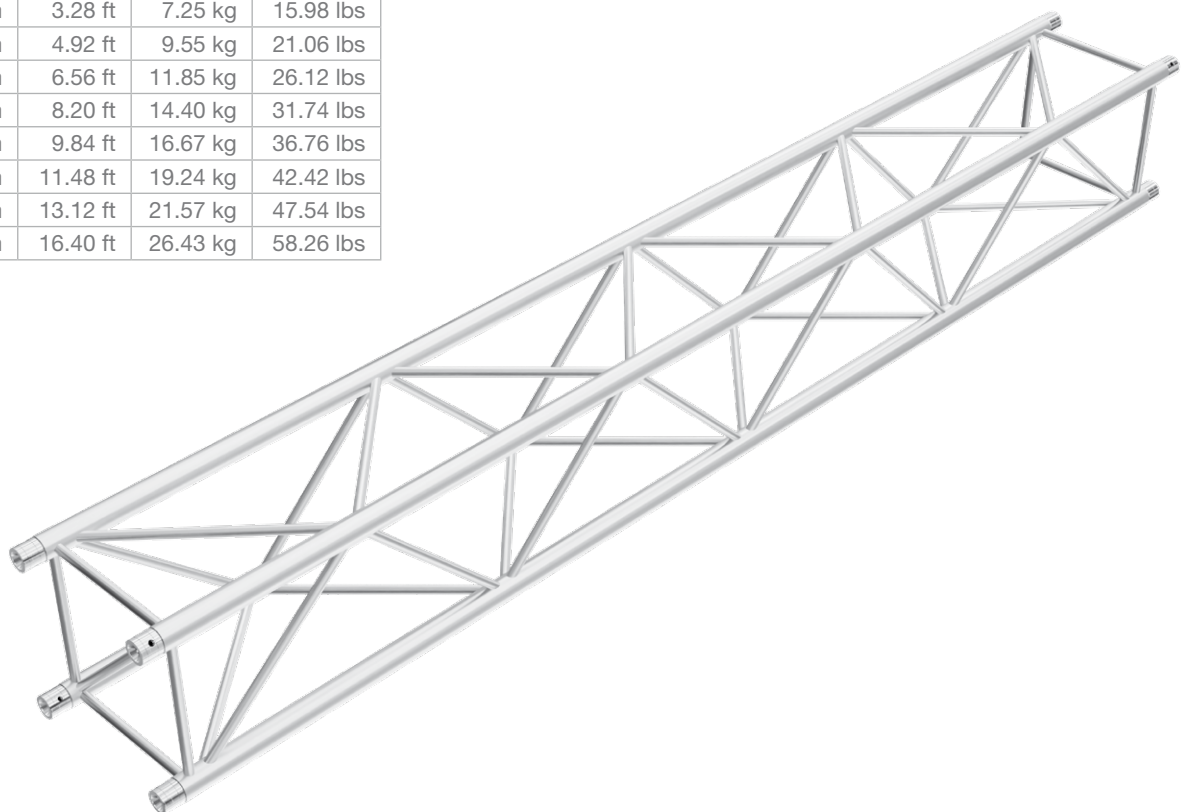

SPECIFICATIONS

Tubes	48 x 3 mm (1.89 x 0.12 in)
Braces	20 x 2 mm (0.79 x 0.08 in)
Alloy	EN AW-6082 T6

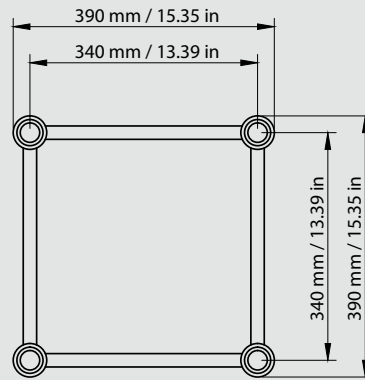

LOADING TABLES

		2 m	4 m	6 m	8 m	10 m	12 m
UDL [kg/m]		835	414	274	204	162	126
Deflection [mm]		0.5	4.1	13.8	32.8	64.1	104.6
CPL [kg]		1669	1656	1483	1138	913	755
Deflection [mm]		0.8	6.5	19.8	36.5	58.1	84.8
		6.56 ft	13.12 ft	19.68 ft	26.24 ft	32.81 ft	39.37 ft
UDL [lbs/ft]		561.1	278.2	184.1	137.1	108.9	84.7
Deflection [in]		0.002	0.01	0.05	0.1	0.2	0.3
CPL [lbs]		3679.5	3650.9	3269.5	2508.9	2012.8	1664.5
Deflection [in]		0.03	0.3	0.8	1.4	2.3	3.3

Loading tables are valid for static loads and spans with two supporting points. Spans must be supported at each end. Contact structural engineer if there are more supporting points applied or dynamic and wind loads involved. High values of distributed loads are idealized. Loads must be applied to knot points!

STRAIGHT SEGMENT LENGTHS

Code	Length		Weight	
PTH44-50	0.5 m	1.64 ft	5.51 kg	12.15 lbs
PTH44-100	1 m	3.28 ft	8.74 kg	19.28 lbs
PTH44-150	1.5 m	4.92 ft	11.66 kg	25.71 lbs
PTH44-200	2 m	6.56 ft	14.66 kg	32.32 lbs
PTH44-250	2.5 m	8.20 ft	17.87 kg	39.40 lbs
PTH44-300	3 m	9.84 ft	20.81 kg	45.87 lbs
PTH44-350	3.5 m	11.48 ft	24.04 kg	52.99 lbs
PTH44-400	4 m	13.12 ft	27.02 kg	59.57 lbs
PTH44-500	5 m	16.40 ft	33.2 kg	73.19 lbs

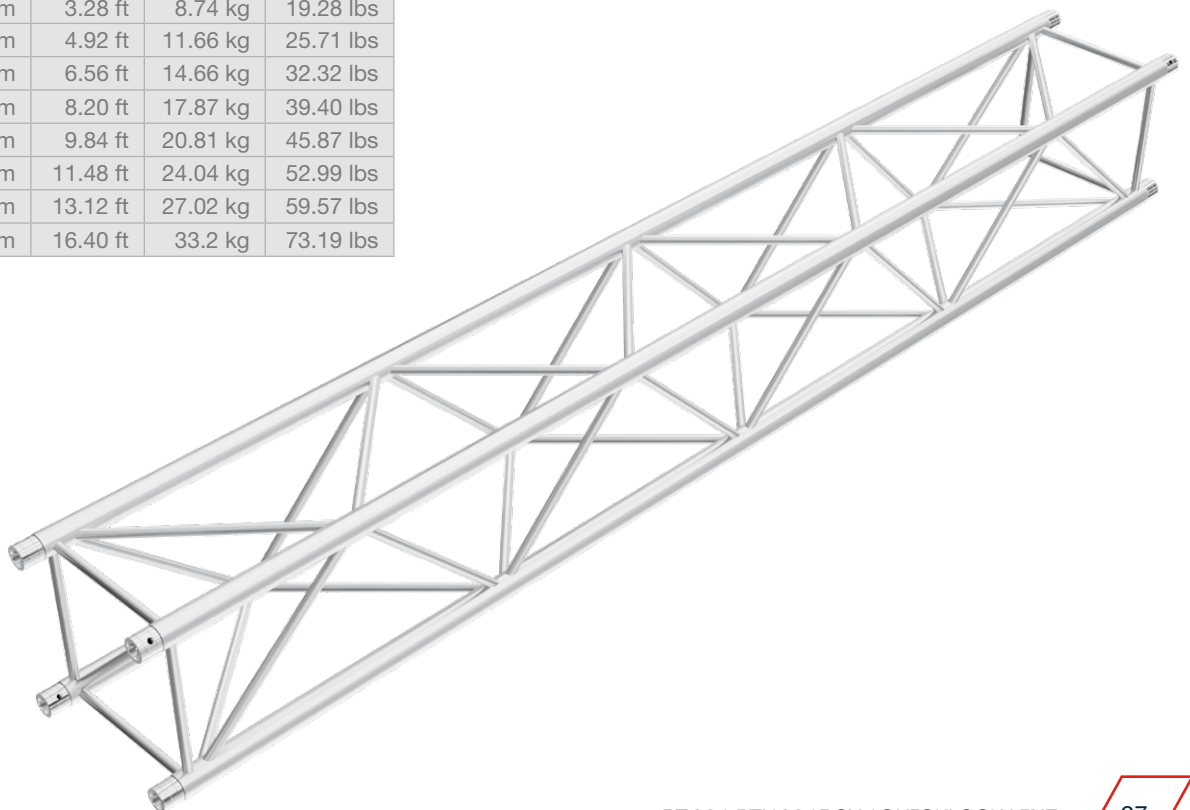

PT44 / PTH44

QUICKLOCK LINE

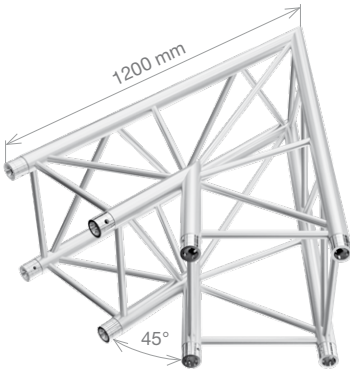

PT44-C19	PTH44-C19
2-way 45° corner	
1.2 m (3.94 ft)	
10.06 kg (22.18 lbs)	12.36 kg (27.15 lbs)

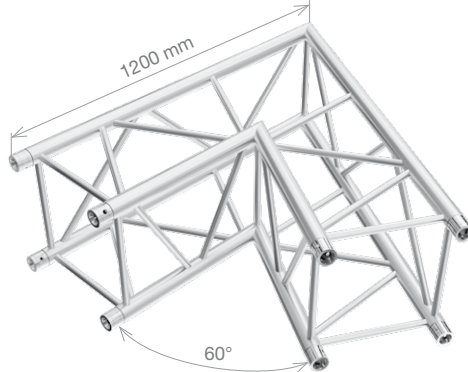

PT44-C20	PTH44-C20
2-way 60° corner	
1.2 m (3.94 ft)	
10.87 kg (22.96 lbs)	13.43 kg (29.61 lbs)

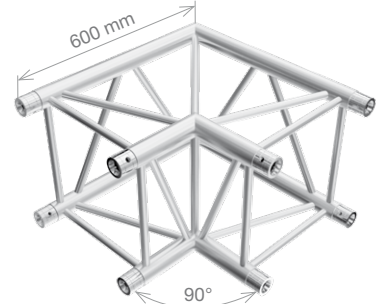

PT44-C21	PTH44-C21
2-way 90° corner	
0.6 m (1.97 ft)	
6.50 kg (14.34 lbs)	7.81 kg (17.23 lbs)

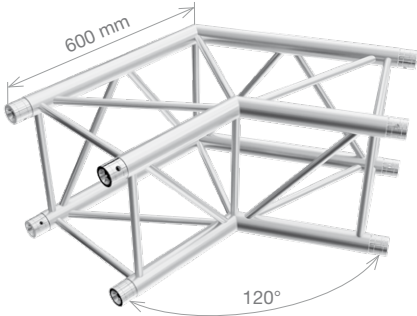

PT44-C22	PTH44-C22
2-way 120° corner	
0.6 m (1.97 ft)	
6.92 kg (15.26 lbs)	12.36 kg (27.15 lbs)

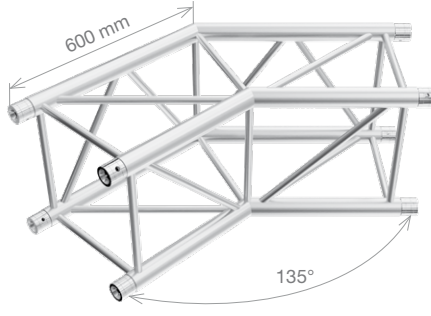

PT44-C23	PTH44-C23
2-way 135° corner	
0.6 m (1.97 ft)	
7.31 kg (16.12 lbs)	8.87 kg (19.56 lbs)

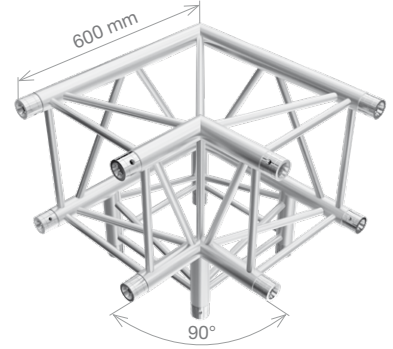

PT44-C30	PTH44-C30
3-way 90° corner	
0.6 m (1.97 ft)	
8.73 kg (19.25 lbs)	10.41 kg (22.96 lbs)

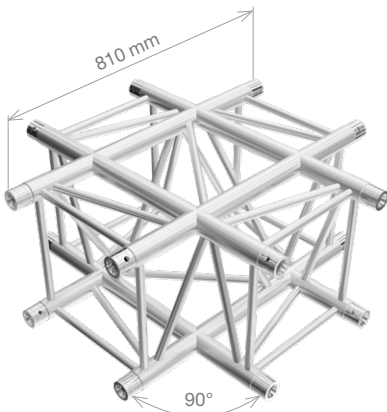

PT44-C41	PTH44-C41
4-way cross junction	
0.81 m (2.66 ft)	
11.86 kg (26.15 lbs)	14.26 kg (31.43 lbs)

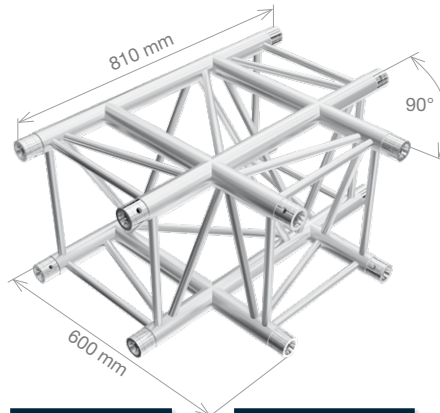

PT44-T35	PTH44-T35
3-way T-junction	
0.81 x 0.6 m (2.66 x 1.97 ft)	
9.59 kg (21.14 lbs)	11.60 kg (25.57 lbs)

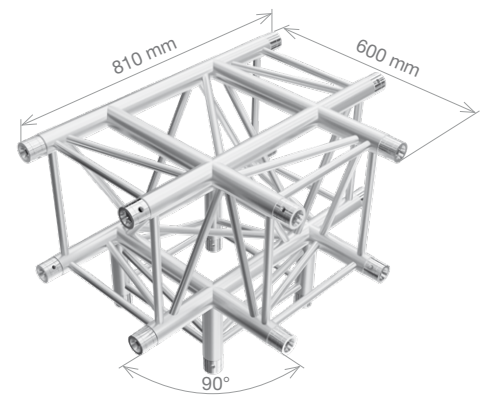

PT44-T42	PTH44-T42
4-way T-junction	
0.81 x 0.6 m (2.66 x 1.97 ft)	
11.84 kg (26.11 lbs)	14.25 kg (31.42 lbs)

CORNERS

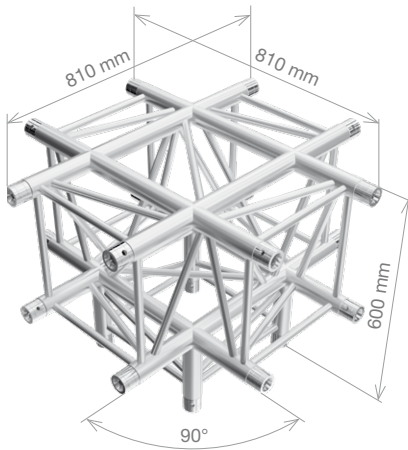

PT44-C51

PTH44-C51

	5-way junction
	0.81 m (2.66 ft)
	14.10 kg (31.08 lbs)
	16.83 kg (37.11 lbs)

PT44-MCB

PTH44-MCB

	Multi connection box
	0.39 x 0.39 m (1.28 x 1.28 ft)
	9.81 kg (21.64 lbs)
	9.81 kg (21.64 lbs)

Includes connection sets for two ways.

CIRCLES

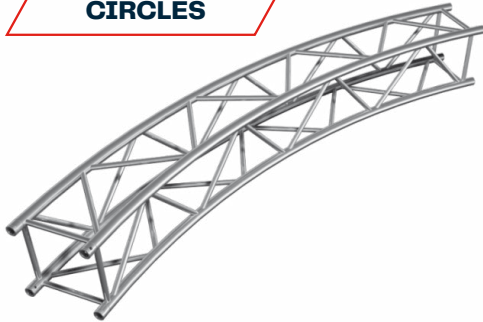

PT44-C

PTH44-C

	Circle, various diameters
--	---------------------------



SPECIFICATIONS

Tubes	50 x 4 mm (1.97 x 0.16 in)
Braces	25 x 3 mm (0.98 x 0.12 in)
Alloy	EN AW-6082 T6

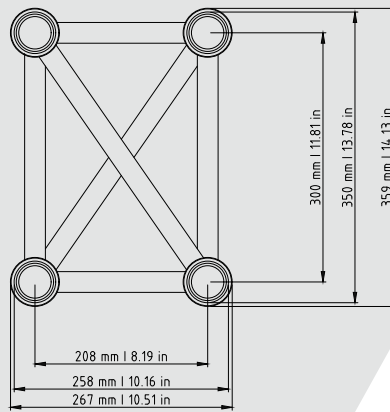

LOADING TABLES

		4 m	6 m	8 m	10 m	12 m	14 m	16 m	18 m	20 m
UDL [kg/m]		1027	560	320	204	140	101	75	57	45
Deflection [mm]		12	29	51	79	114	155	202	256	317
CPL [kg]		1992	1451	1131	919	767	652	561	486	424
Deflection [mm]		10	21	37	58	85	118	157	202	254
TPL [kg]		1305	987	786	648	547	469	406	355	312
Deflection [mm]		10	24	43	69	102	142	188	242	304
QPL [kg]		1027	801	613	491	405	342	292	252	219
Deflection [mm]		11	26	47	73	105	143	188	240	298
FPL [kg]		861	621	480	387	321	272	233	201	175
Deflection		12	26	46	72	105	145	190	243	302
		13.12 ft	19.69 ft	26.25 ft	32.81 ft	39.37 ft	45.93 ft	52.49 ft	59.06 ft	65.62 ft
UDL [lbs/ft]		690.11	376.30	215.03	137.08	94.08	67.87	50.40	38.30	30.24
Deflection [in]		0.47	1.14	2.01	3.11	4.49	6.10	7.95	10.08	12.48
CPL [lbs]		4391.61	3198.91	2493.43	2026.05	1690.95	1437.41	1236.79	1071.45	934.76
Deflection [in]		0.39	0.83	1.46	2.28	3.35	4.65	6.18	7.95	10.00
TPL [lbs]		2876.64	2175.67	1732.60	1428.40	1205.76	1033.83	894.95	782.53	687.75
Deflection [in]		0.39	0.94	1.69	2.72	4.02	5.59	7.40	9.53	11.97
QPL [lbs]		1898.18	1369.07	1058.22	853.19	707.68	599.66	513.68	443.13	385.81
Deflection [in]		0.43	1.02	1.85	2.87	4.13	5.63	7.40	9.45	11.73
FPL [lbs]		1898.18	1369.07	1058.22	853.19	707.68	599.66	513.68	443.13	385.81
Deflection [in]		0.47	1.02	1.81	2.83	4.13	5.71	7.48	9.57	11.89

Loading tables are valid for static loads and spans with two supporting points. Spans must be supported at each end. Contact structural engineer if there are more supporting points applied or dynamic and wind loads involved.

STRAIGHT SEGMENT LENGTHS

Code	Length		Weight	
TS36R-100	1 m	1.64 ft	14.23 kg	31.37 lbs
TS36R-120	1.2 m	3.94 ft	15.62 kg	34.44 lbs
TS36R-200	2 m	6.56 ft	22.38 kg	49.35 lbs
TS36R-300	3 m	9.84 ft	30.10 kg	66.37 lbs

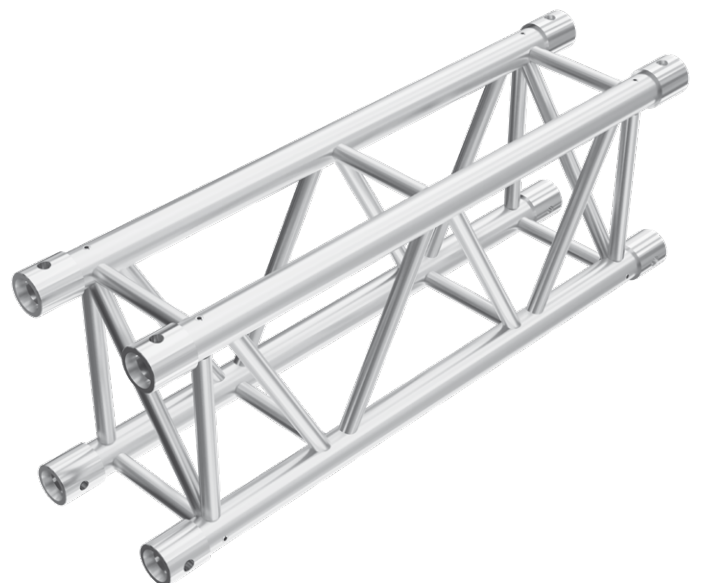

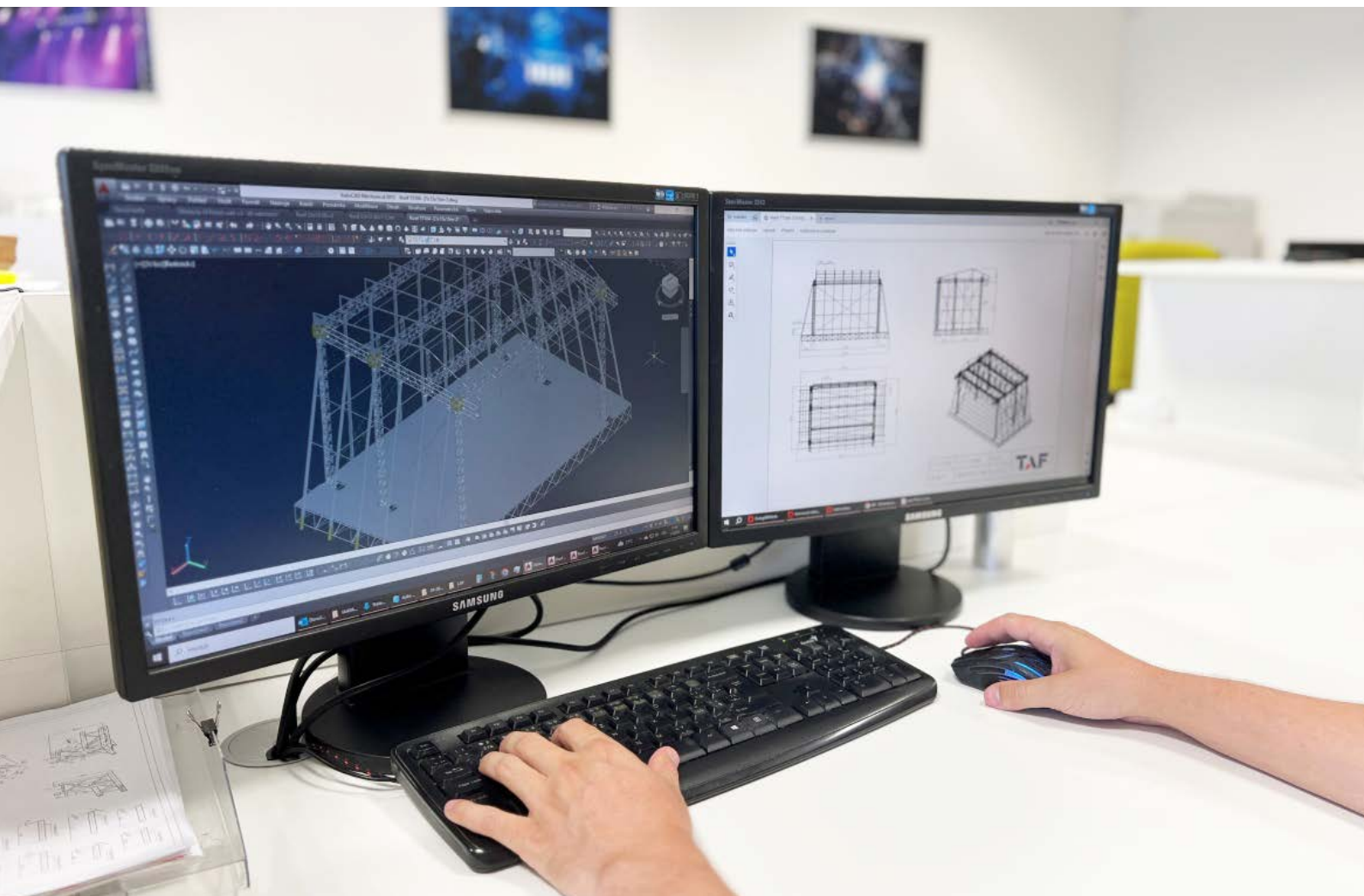

DESIGN AND ENGINEERING

TAF's advanced design and engineering services are trusted worldwide, thanks to its expert in-house Design & Engineering team. With extensive experience in structural design and engineering, TAF ensures top-tier quality, safety, and reliability. Whether you need custom truss segments, innovative connection solutions, or lightweight structures, TAF delivers precision-engineered solutions tailored to your needs.

TAF engineers approach every project with a commitment to excellence, using cutting-edge technology and best practices to ensure optimal results. From small components to large-scale structures, each design prioritizes safety, efficiency, and aesthetics.

TAF is dedicated to delivering innovative, safe, and durable support structures. Whether for events, architecture, or industrial applications, TAF's team ensures success by providing world-class design and engineering solutions.

Top-Level Services Offered by TAF:

- **Design:** Expertly crafted designs and 3D models for optimized, high-performance structures.
- **Engineering:** Precise calculations and material specifications to ensure structural integrity.
- **Custom Projects:** Tailored truss and support solutions for unique project requirements.
- **Bespoke Projects:** Highly specialized structures designed to meet specific client needs.
- **Static Calculations:** Essential load assessments ensuring safety and durability.

SPECIFICATIONS

Tubes	50 x 4 mm (1.97 x 0.16 in)
Braces	30 x 3 mm (1.18 x 0.12 in)
Alloy	EN AW-6082 T6

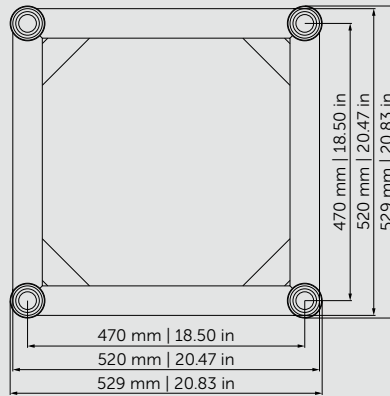

LOADING TABLES

		4 m	6 m	8 m	10 m	12 m	14 m	16 m	18 m	20 m	22 m
UDL [kg/m]		1443	957	543	343	234	168	126	96	76	60
Deflection [mm]		5	18	33	51	73	100	131	166	206	250
CPL [kg]		3398	2578	2072	1713	1403	1178	1005	868	755	661
Deflection [mm]		5	13	25	41	60	82	108	138	172	210
TPL [kg]		2141	1689	1391	1180	1023	883	754	651	567	496
Deflection [mm]		5	14	28	47	70	96	122	150	179	209
QPL [kg]		1428	1126	927	787	682	589	503	434	378	331
Deflection [mm]		5	13	26	43	65	89	113	139	166	194
FPL [kg]		1129	900	747	637	554	490	419	362	315	275
Deflection		5	14	27	45	67	94	120	148	177	206
		13.12 ft	19.69 ft	26.25 ft	32.81 ft	39.37 ft	45.93 ft	52.49 ft	59.06 ft	65.62 ft	72.18 ft
UDL [lbs/ft]		969.65	643.07	364.88	230.49	157.24	112.89	84.67	64.51	51.07	40.32
Deflection [in]		0.20	0.71	1.30	2.01	2.87	3.94	5.16	6.54	8.11	9.84
CPL [lbs]		7491.31	5683.52	4567.98	3776.52	3093.09	2597.05	2215.65	1913.61	1664.49	1457.26
Deflection [in]		0.20	0.51	0.98	1.61	2.36	3.23	4.25	5.43	6.77	8.27
TPL [lbs]		4720.10	3723.61	3066.63	2601.45	2255.33	1946.68	1662.29	1435.21	1250.02	1093.49
Deflection [in]		0.20	0.55	1.10	1.85	2.76	3.78	4.80	5.91	7.05	8.23
QPL [lbs]		3148.20	2482.41	2043.69	1735.04	1503.55	1298.52	1108.93	956.81	833.35	729.73
Deflection [in]		0.20	0.51	1.02	1.69	2.56	3.50	4.45	5.47	6.54	7.64
FPL [lbs]		2489.02	1984.16	1646.85	1404.34	1221.36	1080.27	923.74	798.07	694.46	606.27
Deflection [in]		0.20	0.55	1.06	1.77	2.64	3.70	4.72	5.83	6.97	8.11

Loading tables are valid for static loads and spans with two supporting points. Spans must be supported at each end. Contact structural engineer if there are more supporting points applied or dynamic and wind loads involved.

STRAIGHT SEGMENT LENGTHS

Code	Length		Weight	
TT54M-50	0.5 m	1.64 ft	15.75 kg	34.72 lbs
TT54M-100	1 m	3.28 ft	21.17 kg	46.67 lbs
TT54M-200	2 m	6.56 ft	34.2 kg	75.40 lbs
TT54M-250	2.5 m	8.20 ft	43.11 kg	95.01 lbs
TT54M-300	3 m	9.84 ft	47.25 kg	104.19 lbs
TT54M-400	4 m	13.12 ft	59.87 kg	132.00 lbs

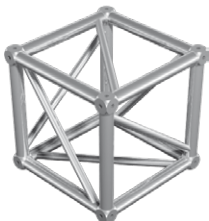

TT54M-MCB

	Multi connection box
	0.52 x 0.52 m (1.71 x 1.71 ft)
	19.74 kg (43.53 lbs)

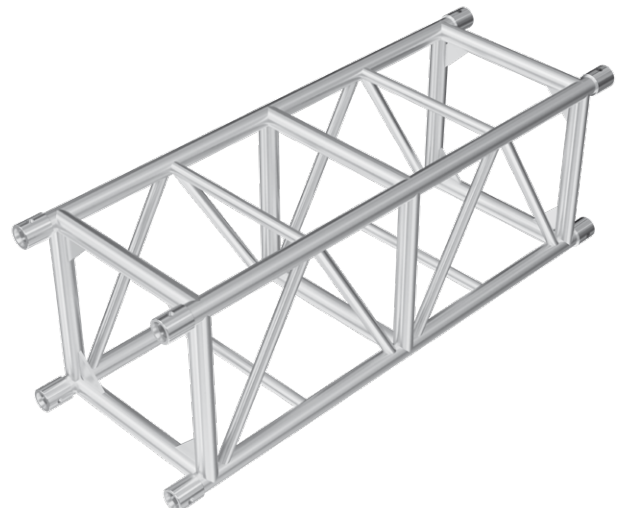

SPECIFICATIONS

Tubes	50 x 4 mm (1.97 x 0.16 in)
Braces	30 x 3 mm (1.18 x 0.12 in)
Alloy	EN AW-6082 T6

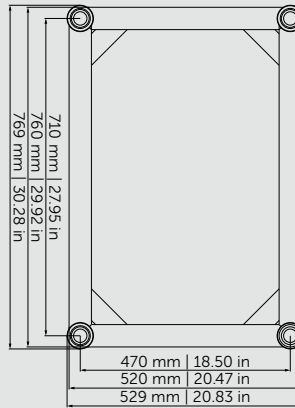

LOADING TABLES

		4 m	6 m	8 m	10 m	12 m	14 m	16 m	18 m	20 m	22 m	24 m	26 m	28 m	30 m	32 m
UDL [kg/m]		1085	718	534	424	351	258	194	150	118	95	77	63	52	44	36
Deflection [mm]		2	6	14	28	48	66	87	110	136	165	197	232	271	312	356
CPL [kg]		3122	2593	2209	1918	1689	1504	1353	1225	1117	1024	927	824	734	654	582
Deflection [mm]		2	6	12	20	32	46	63	83	107	135	165	196	230	268	308
TPL [kg]		1785	1541	1351	1199	1075	972	885	810	745	688	638	594	551	490	436
Deflection [mm]		2	6	12	21	32	46	63	82	103	127	153	181	210	230	248
QPL [kg]		1190	1027	901	800	717	648	590	540	497	459	426	396	367	327	291
Deflection [mm]		2	5	11	19	30	43	58	76	96	118	142	168	195	214	231
FPL [kg]		919	800	707	631	569	516	471	433	399	370	343	320	299	272	242
Deflection		2	5	11	19	30	44	60	78	98	121	146	173	202	227	245
		13.12 ft	19.69 ft	26.25 ft	32.81 ft	39.37 ft	45.93 ft	52.49 ft	59.06 ft	65.62 ft	72.18 ft	78.74 ft	85.3 ft	91.86 ft	98.43 ft	104.99 ft
UDL [lbs/ft]		729.09	482.47	358.83	284.92	235.86	173.37	130.36	100.80	79.29	63.84	51.74	42.33	34.94	29.57	24.19
Deflection [in]		0.08	0.24	0.55	1.10	1.89	2.60	3.43	4.33	5.35	6.50	7.76	9.13	10.67	12.28	14.02
CPL [lbs]		6882.83	5716.59	4870.01	4228.47	3723.61	3315.75	2982.85	2700.66	2462.56	2257.53	2043.69	1816.61	1618.19	1441.82	1283.09
Deflection [in]		0.08	0.24	0.47	0.79	1.26	1.81	2.48	3.27	4.21	5.31	6.50	7.72	9.06	10.55	12.13
TPL [lbs]		3935.25	3397.32	2978.45	2643.34	2369.97	2142.89	1951.09	1785.74	1642.44	1516.78	1406.55	1309.55	1214.75	1080.27	961.22
Deflection [in]		0.08	0.24	0.47	0.83	1.26	1.81	2.48	3.23	4.06	5.00	6.02	7.13	8.27	9.06	9.76
QPL [lbs]		2623.50	2264.15	1986.36	1763.70	1580.71	1428.60	1300.73	1190.50	1095.70	1011.92	939.17	873.03	809.10	720.91	641.55
Deflection [in]		0.08	0.20	0.43	0.75	1.18	1.69	2.28	2.99	3.78	4.65	5.59	6.61	7.68	8.43	9.09
FPL [lbs]		2026.05	1763.70	1558.67	1391.12	1254.43	1137.59	1038.38	954.60	879.64	815.71	756.19	705.48	659.18	599.66	533.52
Deflection [in]		0.08	0.20	0.43	0.75	1.18	1.73	2.36	3.07	3.86	4.76	5.75	6.81	7.95	8.94	9.65

Loading tables are valid for static loads and spans with two supporting points. Spans must be supported at each end. Contact structural engineer if there are more supporting points applied or dynamic and wind loads involved.

STRAIGHT SEGMENT LENGTHS

Code	Length		Weight	
TT74M-50	0.5 m	1.64 ft	17.62 kg	38.85 kg
TT74M-100	1 m	3.28 ft	23.28 kg	51.31 kg
TT74M-200	2 m	6.56 ft	37.43 kg	82.52 kg
TT74M-250	2.5 m	8.20 ft	47.94 kg	105.68 kg
TT74M-300	3 m	9.84 ft	51.82 kg	114.24 kg
TT74M-400	4 m	13.12 ft	65.49 kg	144.38 kg

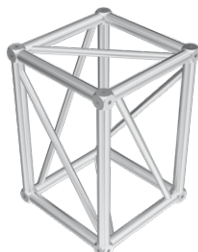

TT74M-MCB

	Multi connection box
	0.52 x 0.76 x 0.52 m (1.71 x 2.49 x 1.71 ft)
	21.64 kg (47.70 lbs)

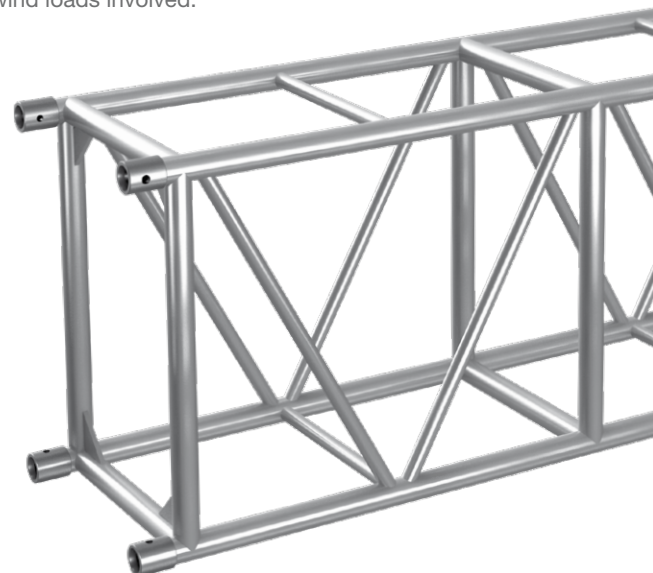

SPECIFICATIONS

Tubes	60 x 6 mm (2.36 x 0.24 in)
Braces	30 x 3 mm (1.18 x 0.12 in)
Alloy	EN AW-6082 T6

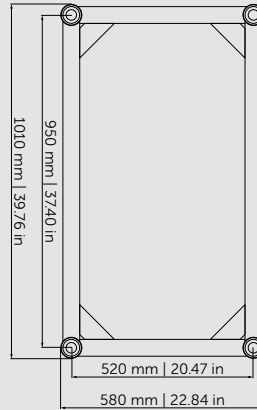

LOADING TABLES

		8 m	10 m	12 m	14 m	16 m	18 m	20 m	22 m	24 m
UDL [kg/m]		1441.6	1148.7	835.7	607.9	460	358.7	286.2	232.5	191.7
Deflection [mm]		11.9	23.3	35.4	48.3	63.1	80	98.9	119.9	142.9
CPL [kg]		5880*	5157*	4513*	4000*	3570*	3196*	2861.7	2557.8	2300.7
Deflection [mm]		9.8	16.9	25.8	36.8	49.7	64.4	80.7	98.3	117.7
TPL [kg]		3608	3276	2933	2681	2429	2227	2039	1880	1725.5
Deflection [mm]		10.2	18.2	28.4	41.7	57.1	75.5	96.3	120.1	145.7
QPL [kg]		2673	2457	2256	2085	1840.2	1614	1430.9	1278.9	1150.3
Deflection [mm]		10.5	19	30.4	45.1	60.1	76.2	94.3	114.5	136.6
FPL [kg]		2134	1997	1859	1738	1533.5	1345	1192.4	1065.7	958.6
Deflection		10.7	19.7	31.9	47.7	63.6	80.6	99.6	120.7	143.9
		26.25 ft	32.81 ft	39.37 ft	45.93 ft	52.49 ft	59.06 ft	65.62 ft	72.18 ft	78.74 ft
UDL [lbs/ft]		968.71	771.89	561.56	408.49	309.11	241.04	192.32	156.23	128.82
Deflection [in]		0.47	0.92	1.39	1.90	2.48	3.15	3.89	4.72	5.63
CPL [lbs]		12963.18	11369.24	9949.46	8818.49	7870.50	7045.97	6308.97	5638.98	5072.18
Deflection [in]		0.39	0.67	1.02	1.45	1.96	2.54	3.18	3.87	4.63
TPL [lbs]		7954.28	7222.34	6466.16	5910.59	5355.03	4909.69	4495.23	4144.69	3804.08
Deflection [in]		0.40	0.72	1.12	1.64	2.25	2.97	3.79	4.73	5.74
QPL [lbs]		5892.96	5416.76	4973.63	4596.64	4056.95	3558.26	3154.59	2819.49	2535.98
Deflection [in]		0.41	0.75	1.20	1.78	2.37	3.00	3.71	4.51	5.38
FPL [lbs]		4704.66	4402.63	4098.39	3831.63	3380.79	2965.22	2628.79	2349.47	2113.35
Deflection [in]		0.42	0.78	1.26	1.88	2.50	3.17	3.92	4.75	5.67

Loading tables are valid for static loads and spans with two supporting points. Spans must be supported at each end. Contact structural engineer if there are more supporting points applied or dynamic and wind loads involved.

High values of distributed loads are idealized. Loads must be applied to knot points!

* limited by interaction of shear and movement at the connection

Displacement connection is decisive!

STRAIGHT SEGMENT LENGTHS

Code	Length		Weight	
TT104M-100	1 m	3.28 ft	27.04 kg	59.61 lbs
TT104M-200	2 m	6.56 ft	46.13 kg	101.69 lbs
TT104M-300	3 m	9.84 ft	65.21 kg	143.76 lbs

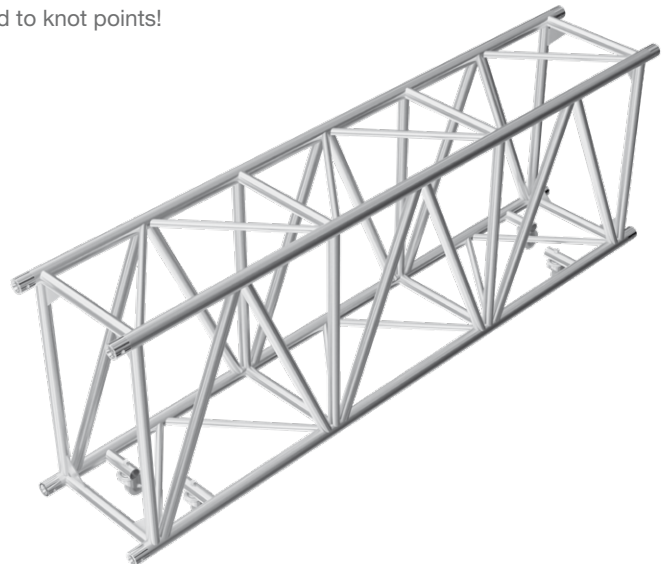

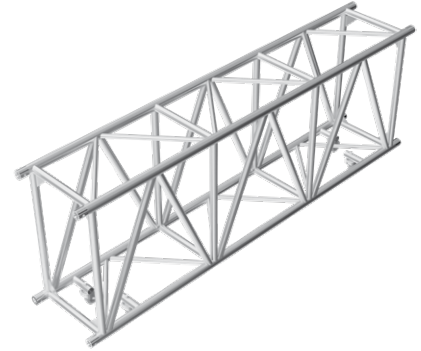
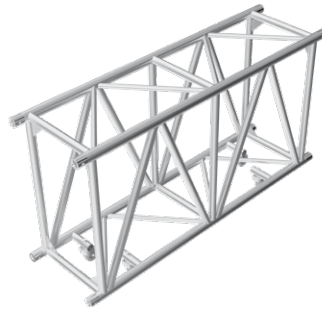

TT104M-100

Straight segment
 1 m (3.28 ft)
 27.04 kg (59.61 lbs)

TT104M-200

Straight segment
 2 m (6.56 ft)
 46.13 kg (101.69 lbs)

TT104M-300

Straight segment
 3 m (9.84 ft)
 65.21 kg (143.76 lbs)

26 m	28 m	30 m	32 m	34 m	36 m	38 m	40 m	42 m
160	134.8	114.4	97.8	84	72.5	62.7	54.3	47.2
168.1	195.3	224.8	256.4	290.2	326.3	364.6	405.3	448.3
2079.6	1886.8	1716.7	1564.9	1428.4	1304.4	1191.1	1086.8	990.3
139.1	162.5	188	215.7	245.7	278	312.8	350.1	390.1
1559.7	1415.1	1287.5	1173.7	1071.3	978.3	893.3	815.1	742.7
171.3	199	228.9	260.9	295.2	331.6	370.4	411.4	454.7
1039	943.4	858.3	782.5	714.2	652.2	595.5	543.4	495.1
160.8	187.1	215.6	246.2	279.1	314.2	351.6	391.5	433.7
866.5	786.2	715.3	652.1	595.2	543.5	496.3	452.8	412.6
169.2	196.7	226.2	258	292	328.2	366.7	407.5	450.6
85.3 ft	91.86 ft	98.43 ft	104.99 ft	111.55 ft	118.11 ft	124.67 ft	131.23 ft	137.80 ft
107.52	90.58	76.87	65.72	56.45	48.72	42.13	36.49	31.72
6.62	7.69	8.85	10.09	11.43	12.85	14.35	15.96	17.65
4584.73	4159.68	3784.68	3450.01	3149.08	2875.71	2625.93	2395.98	2183.24
5.48	6.40	7.40	8.49	9.67	10.94	12.31	13.78	15.36
3438.55	3119.76	2838.45	2587.57	2361.81	2156.78	1969.39	1796.99	1637.37
6.74	7.83	9.01	10.27	11.62	13.06	14.58	16.20	17.90
2290.60	2079.84	1892.23	1725.12	1574.54	1437.85	1312.85	1197.99	1091.51
6.33	7.37	8.49	9.69	10.99	12.37	13.84	15.41	17.07
1910.31	1733.27	1576.97	1437.63	1312.19	1198.21	1094.15	998.25	909.63
6.66	7.74	8.91	10.16	11.50	12.92	14.44	16.04	17.74

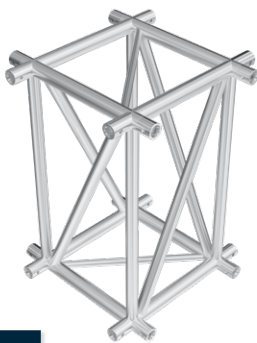

TT104M-C41

Four-way corner
 0.52 x 1.01 x 0.52 m
 (1.71 x 3.31 x 1.71 ft)
 28.25 kg (62.27 lbs)



5441

Conical connector, diam. 45 mm (1.77 in) for TS36R, TT54M, TT74M, TT104M



5446

Connection set for TS36R, TT54M, TT74M, TT104M

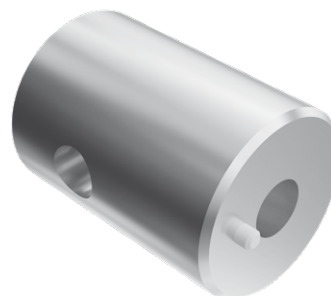

5445-M

Female fitting for TS36R, TT54M, TT74M, TT104M



5442-M

Pin for TS36R, TT54M, TT74M, TT104M



4343

Safety clip for TS36R, TT54M, TT74M, TT104M

HOW TO READ TAF LOADING TABLES

Understanding the structural capacity of a truss system is critical for ensuring safety, performance, and compliance. TAF loading tables provide essential engineering data that helps structural designers, riggers, architects, builders, and engineers determine which truss size and configuration can safely support the required loads over specific spans.

LOADING TABLES		1.52 m	3.05 m	4.57 m	6.1 m	7.6 m	9.14 m	12.2 m
UDL [kg/m]		1982	980	649	482	382	272	145
Deflection [mm]		0.1	0.8	2.5	6	11.8	17.6	31.5
CPL [kg]		3013	2989	2594	1922	1516	1241	887
Deflection [mm]		0.2	1.4	4	7.2	11.2	16.2	29
		5 ft	10 ft	15 ft	20 ft	25 ft	30 ft	40 ft
UDL [lbs/ft]		1332	659	436	324	257	183	97
Deflection [in]		0.01	0.03	0.1	0.2	0.5	0.7	1.2
CPL [lbs]		6644	6591	5720	4238	3343	2736	1956
Deflection [in]		0.01	0.1	0.2	0.3	0.4	0.6	1.1

Why They're Important

Loading tables simplify complex engineering into practical data. They help:

- Prevent structural failure by matching spans to appropriate loads
- Optimize material use and reduce costs
- Ensure compliance with building regulations

Always refer to these tables during planning and installation for safe and reliable construction.

Load Types Explained

TAF loading tables include five types of load applications, simulating different real-world conditions:

- **UDL (Uniformly Distributed Load)** Load spread evenly across the entire span—common in support structures.
- **CPL (Central Point Load)** Load concentrated at the center—used for centered support of equipment or beams.
- **TPL (Three Point Load)** Load divided over three points—typical for compact, localized loads.
- **QPL (Four Point Load)** Load spread across four points—ideal for longer support of equipment.
- **FPL (Five Point Load)** Load across five points—used in solar arrays or walkways.

Each load type includes deflection values, showing how much the truss will bend under weight. Keep deflection within acceptable limits to ensure safety and performance.

Note - Tables apply to static loads with two supports. For dynamic loads or additional support points, consult a structural engineer.



BOLTED TRUSS

TAF's bolted truss consists of three lines – light-duty, medium-duty and heavy-duty. The bolted connection system consists of two aluminium plates, located at the ends of each truss segment, that are secured together with four bolts, which come as standard.

Custom lengths and shapes, in metric and imperial sizes, are available on request.

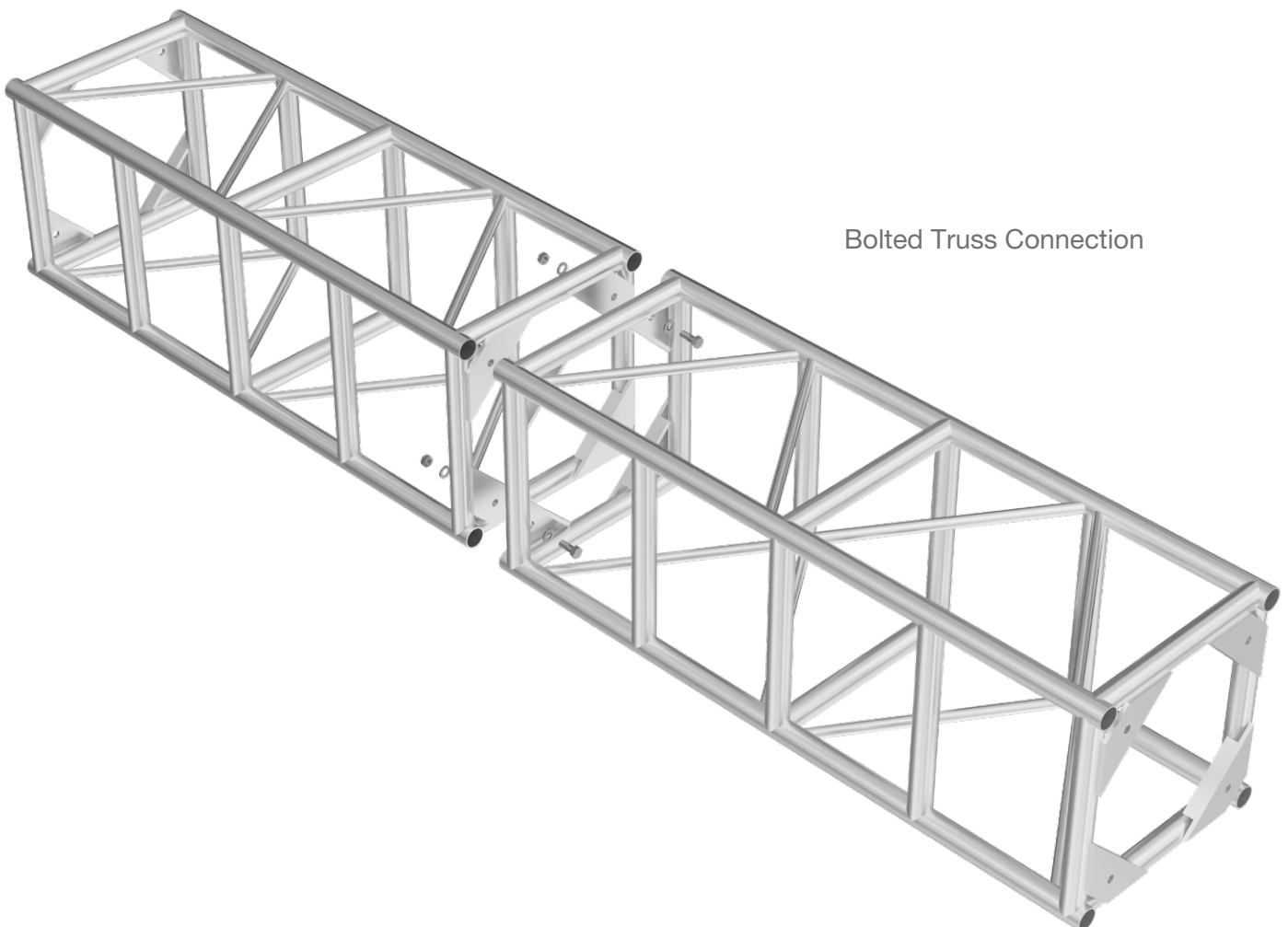

Bolted Truss Connection

SPECIFICATIONS

Tubes	50 x 3 mm (1.97 x 0.12 in)
Braces	25 x 3 mm (0.98 x 0.12 in)
Alloy	EN AW-6082 T6

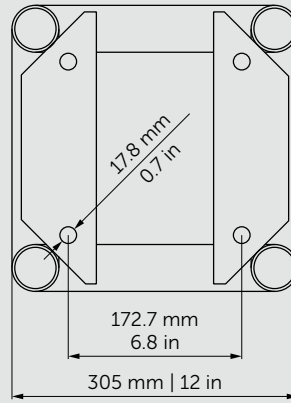

LOADING TABLES

		1.52 m	3.05 m	4.57 m	6.1 m	7.6 m	9.14 m	12.2 m
UDL [kg/m]		1512	605	342	187	116	77	38
Deflection [mm]		0.6	3.6	10.6	18.9	29.6	42.8	77
CPL [kg]		1149	922	782	571	442	353	234
Deflection [mm]		0.5	3.3	9.7	17.3	27.2	39.3	71.1
		5 ft	10 ft	15 ft	20 ft	25 ft	30 ft	40 ft
UDL [lbs/ft]		1016	407	230	126	78	52	26
Deflection [in]		0.02	0.1	0.4	0.7	1.2	1.7	3
CPL [lbs]		2534	2033	1724	1259	975	778	516
Deflection [in]		0.02	0.1	0.4	0.7	1.1	1.5	2.8

Loading tables are valid for static loads and spans with two supporting points.

Spans must be supported at each end.

Contact structural engineer if there are more supporting points applied or dynamic and wind loads involved.

STRAIGHT SEGMENT LENGTHS

Code	Length		Weight	
	m	ft	kg	lbs
FTB-L-5	1.52 m	5.00 ft	15.09 kg	33.26 lbs
FTB-L-8	2.44 m	8.00 ft	22.01 kg	48.53 lbs
FTB-L-10	3.05 m	10.00 ft	26.12 kg	57.58 lbs

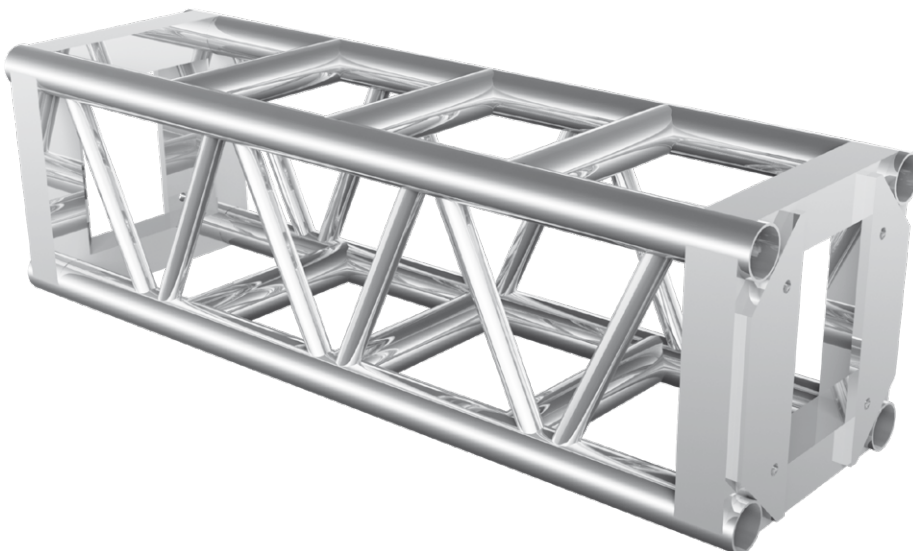

CORNERS

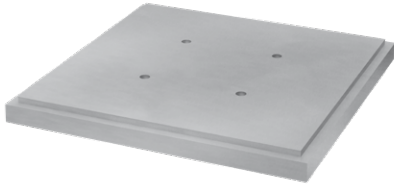

FTB-L-BP

Base plate



FTB-L-G

Grapple for bolted truss attachment

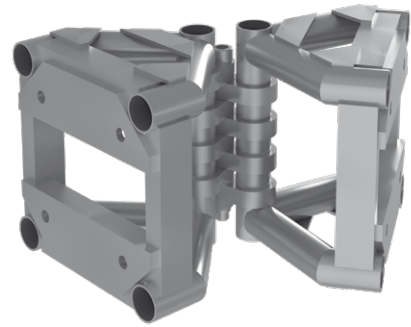

FTB-LVCH

Variable horizontal corner

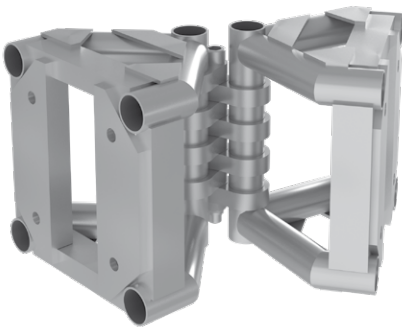

FTB-LVCV

Variable vertical corner

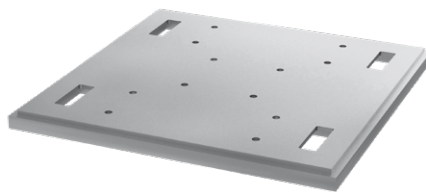

FTB-LMH-BP

Base plate

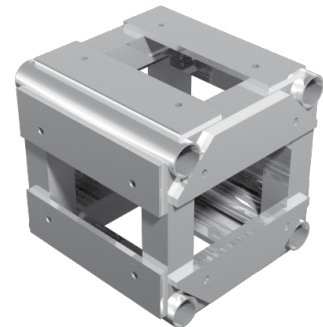

FTB-L-CB-6

Connection box, multiple ways
 11.52 kg (25.39 lbs)

CIRCLES



FTB-L-CH

Horizontal circle, various diameters

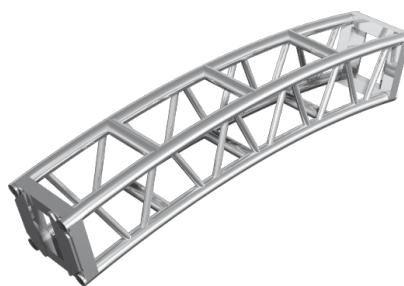

FTB-L-CV

Vertical circle, various diameters

SPECIFICATIONS

Tubes	50 x 3 mm (1.97 x 0.12 in)
Braces	25 x 3 mm (0.98 x 0.12 in)
Alloy	EN AW-6082 T6

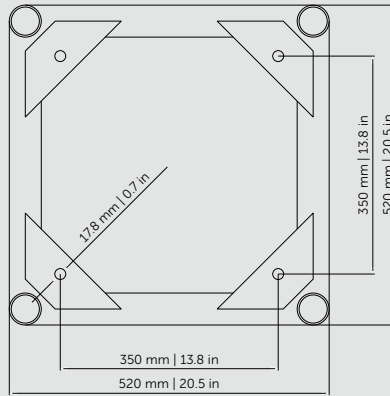

LOADING TABLES

		1.52 m	3.05 m	4.57 m	6.1 m	7.6 m	9.14 m	12.2 m
UDL [kg/m]		2324	1150	694	382	239	162	84
Deflection [mm]		0.2	2	6.2	11.1	17.3	24.9	44.8
CPL [kg]		2879	2251	1585	1166	912	739	512
Deflection [mm]		0.4	2.4	5.7	10.1	15.9	22.9	41.2
		5 ft	10 ft	15 ft	20 ft	25 ft	30 ft	40 ft
UDL [lbs/ft]		1562	773	466	257	161	109	57
Deflection [in]		0.01	0.1	0.2	0.4	0.7	1	1.8
CPL [lbs]		6348	4964	3495	2571	2011	1630	1129
Deflection [in]		0.02	0.1	0.2	0.4	0.6	0.9	1.6

Loading tables are valid for static loads and spans with two supporting points. Spans must be supported at each end.

Contact structural engineer if there are more supporting points applied or dynamic and wind loads involved.

STRAIGHT SEGMENT LENGTHS

Code	Length		Weight	
FTB-M-5	1.52 m	5.00 ft	22.00 kg	48.49 lbs
FTB-M-8	2.44 m	8.00 ft	30.86 kg	68.03 lbs
FTB-M-10	3.05 m	10.00 ft	37.97 kg	83.71 lbs

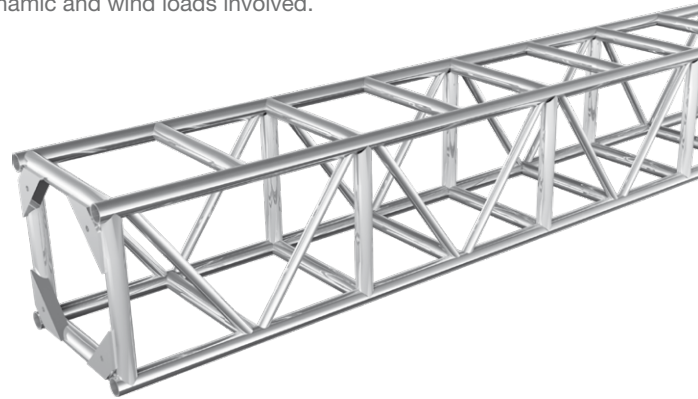

CIRCLES

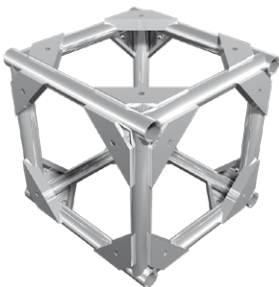

FTB-M-CB-6



Connection box, multiple ways
18.56 kg (40.91 lbs)

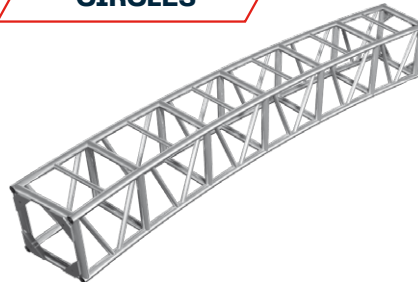

FTB-M-CH



Horizontal circle, various diameters

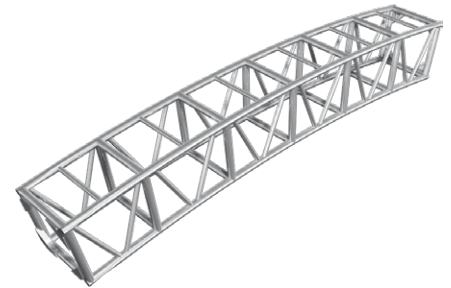

FTB-M-CV



Vertical circle, various diameters

SPECIFICATIONS

Tubes	50 x 3 mm (1.97 x 0.12 in)
Braces	25 x 3 mm (0.98 x 0.12 in)
Alloy	EN AW-6082 T6

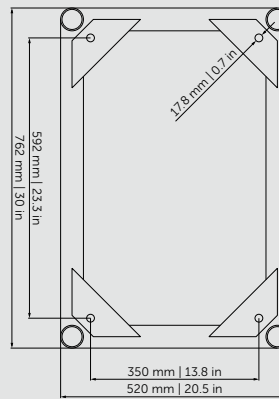

LOADING TABLES

		1.52 m	3.05 m	4.57 m	6.1 m	7.6 m	9.14 m	12.2 m
UDL [kg/m]		1982	980	649	482	382	272	145
Deflection [mm]		0.1	0.8	2.5	6	11.8	17.6	31.5
CPL [kg]		3013	2989	2594	1922	1516	1241	887
Deflection [mm]		0.2	1.4	4	7.2	11.2	16.2	29
		5 ft	10 ft	15 ft	20 ft	25 ft	30 ft	40 ft
UDL [lbs/ft]		1332	659	436	324	257	183	97
Deflection [in]		0.01	0.03	0.1	0.2	0.5	0.7	1.2
CPL [lbs]		6644	6591	5720	4238	3343	2736	1956
Deflection [in]		0.01	0.1	0.2	0.3	0.4	0.6	1.1

Loading tables are valid for static loads and spans with two supporting points. Spans must be supported at each end.

Contact structural engineer if there are more supporting points applied or dynamic and wind loads involved.

STRAIGHT SEGMENT LENGTHS

Code	Length		Weight	
	m	ft	kg	lbs
FTBH-5	1.52 m	5.00 ft	24.65 kg	54.34 lbs
FTBH-8	2.44 m	8.00 ft	34.49 kg	76.03 lbs
FTBH-10	3.05 m	10.00 ft	42.70 kg	94.13 lbs

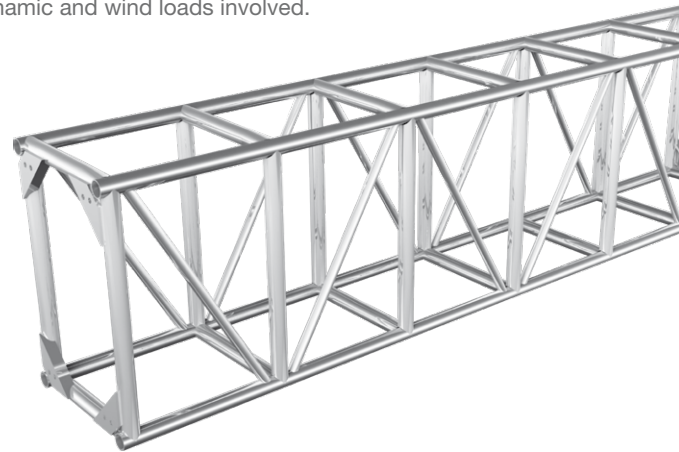

CIRCLES



FTBH-CB-4



Connection box, multiple ways



15.79 kg (34.82 lbs)

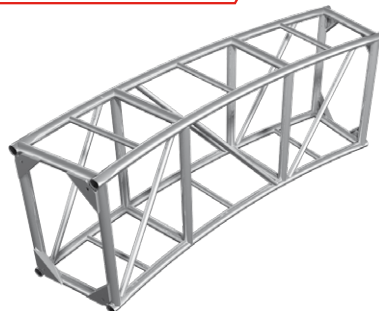

FTBH-CH



Horizontal circle, various diameters

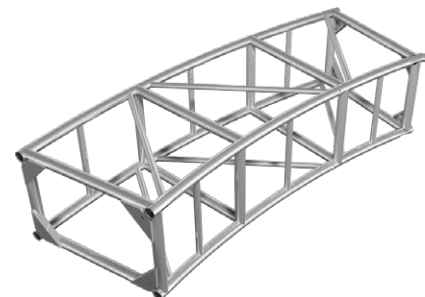

FTBH-CV



Vertical circle, various diameters



FORK TRUSS

Our fork truss system consists of trussing segments that come with fork connectors on each end. One end of the truss features a female set of fork connectors and the other end has a male set of fork connectors, allowing users to easily connect the segments together. The connection is secured by a special fork truss pin and safety clip, which come as standard.

Custom lengths and shapes, in metric and imperial sizes, are available on request.

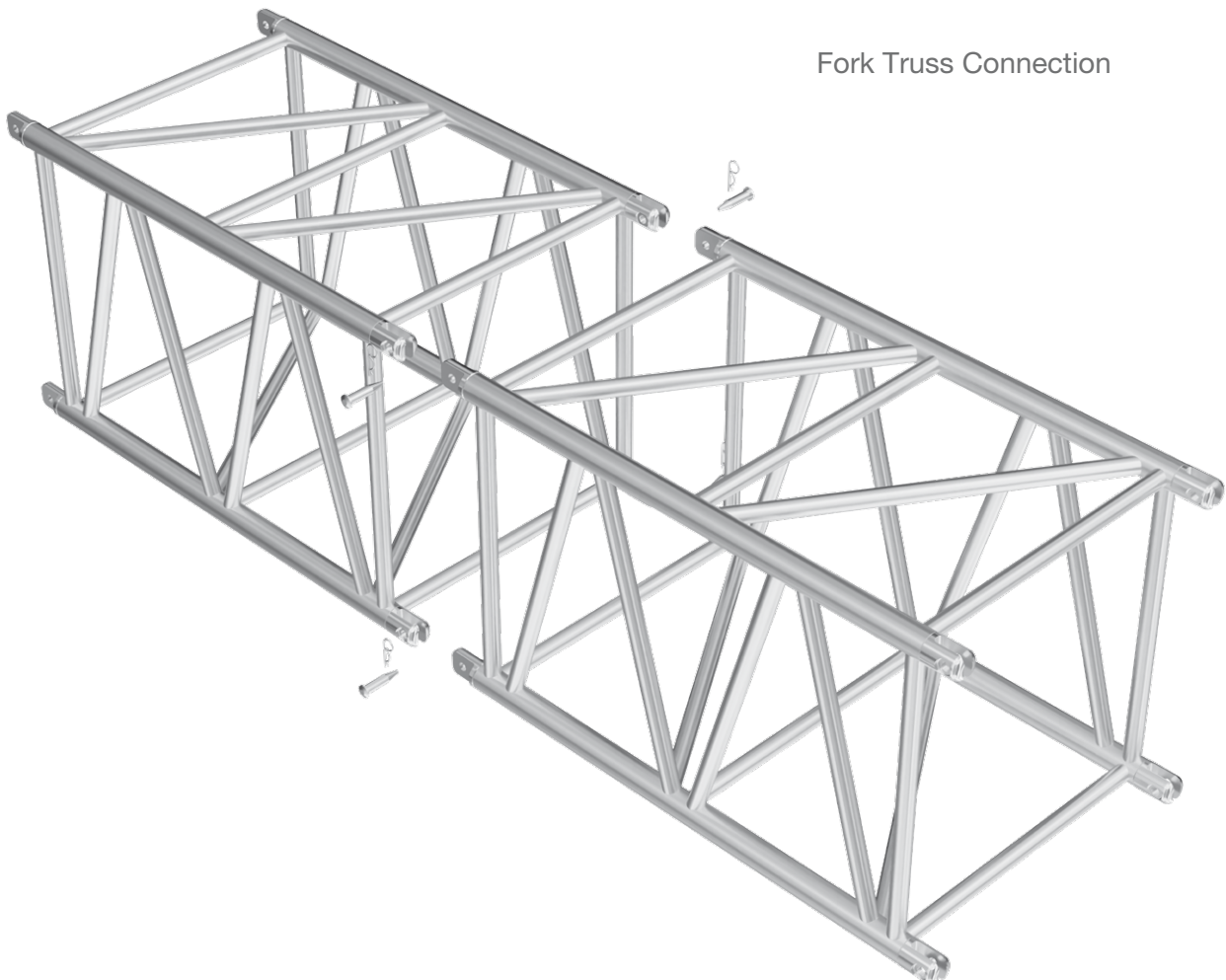

Fork Truss Connection

SPECIFICATIONS

Tubes	48 x 4.5 mm (1.89 x 0.18 in)
Braces	25 x 3 mm (0.98 x 0.12 in)
Alloy	EN AW-6082 T6

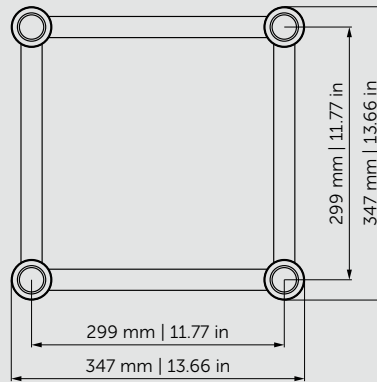

LOADING TABLES

		3 m	4 m	6 m	8 m	10 m	12 m	13 m	14 m	15 m	16 m	17 m
UDL [kg/m]		1578	1180	557	308	195	133	111	94	80	69	60
Deflection [mm]		4.4	10.3	25	44.4	70.2	101.8	119.7	139	159.4	180.8	205.2
CPL [kg]		3276	2539	1672	1231	974	795	724	661	604	552	510
Deflection [mm]		4.8	8.9	20.1	35.9	57	83.2	98.2	114.5	131.8	150.2	171.3
TPL [kg]		2366	1904	1254	924	730	596	543	495	453	414	383
Deflection [mm]		5.9	11.3	25.5	45.4	71.6	103.9	122.1	141.7	162.5	184.2	209
QPL [kg]		1578	1269	836	616	487	398	362	330	302	276	255
Deflection [mm]		5.5	10.6	23.8	42.3	66.9	97.2	144.4	132.9	152.5	173.2	196.7
FPL [kg]		1183	1058	697	513	406	331	302	275	252	230	213
Deflection		5.3	11.3	25.4	45.1	71.3	103.4	121.6	141.1	161.8	183.5	208.1
		9.84 ft	13.12 ft	19.68 ft	26.24 ft	32.8 ft	39.36 ft	42.64 ft	45.92 ft	49.2 ft	52.48 ft	55.76 ft
UDL [lbs/ft]		1060.37	792.92	374.29	206.97	131.03	89.37	74.59	63.17	53.76	46.37	40.32
Deflection [in]		0.17	0.41	0.98	1.75	2.76	4.01	4.71	5.47	6.28	7.12	8.08
CPL [lbs]		7222.34	5597.54	3686.13	2713.89	2147.30	1752.67	1596.15	1457.26	1331.59	1216.95	1124.36
Deflection [in]		0.19	0.35	0.79	1.41	2.24	3.28	3.87	4.51	5.19	5.91	6.74
TPL [lbs]		5216.14	4197.60	2764.60	2037.07	1609.37	1313.96	1197.11	1091.29	998.69	912.71	844.37
Deflection [in]		0.23	0.44	1.00	1.79	2.82	4.09	4.81	5.58	6.40	7.25	8.23
QPL [lbs]		3478.89	2797.67	1843.06	1358.05	1073.65	877.44	798.07	727.53	665.80	608.48	562.18
Deflection [in]		0.22	0.42	0.94	1.67	2.63	3.83	5.69	5.23	6.00	6.82	7.74
FPL [lbs]		2608.07	2332.49	1536.62	1130.97	895.08	729.73	665.80	606.27	555.56	507.06	469.58
Deflection [in]		0.21	0.44	1.00	1.78	2.81	4.07	4.79	5.56	6.37	7.22	8.19

Loading tables are valid for static loads and spans with two supporting points. Spans must be supported at each end. Contact structural engineer if there are more supporting points applied or dynamic and wind loads involved.

STRAIGHT SEGMENT LENGTHS

Code	Length		Weight	
GS350-100	1 m	3.28 ft	13.30 kg	29.32 lbs
GS350-124,3	1.243 m	4 ft	15.14 kg	33.38 lbs
GS350-200	2 m	6.56 ft	22.46 kg	49.52 lbs
GS350-243,8	2.438 m	8 ft	26.46 kg	58.33 lbs
GS350-300	3 m	9.84 ft	31.67 kg	69.82 lbs
GS350-400	4 m	13.12 ft	41.10 kg	90.61 lbs

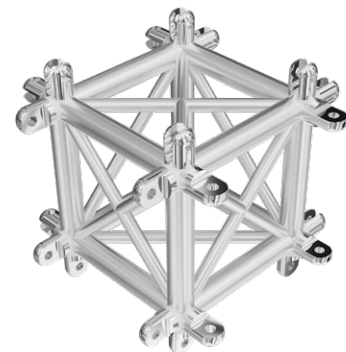

All other corner variants are available on request.

GS350-MCB

	Multi connection box
	15.65 kg (34.50 lbs)

SPECIFICATIONS

Tubes	48 x 4.5 mm (1.89 x 0.18 in)
Braces	30 x 3 mm (1.18 x 0.12 in)
Alloy	EN AW-6082 T6

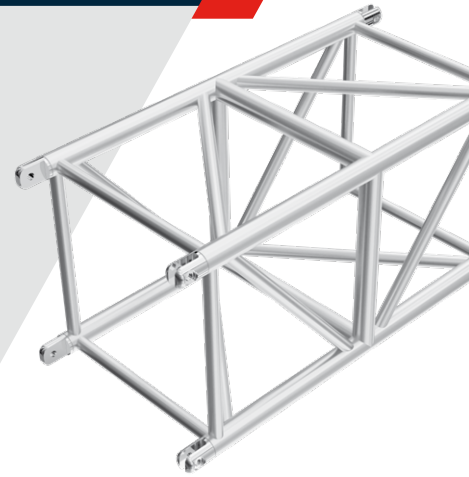
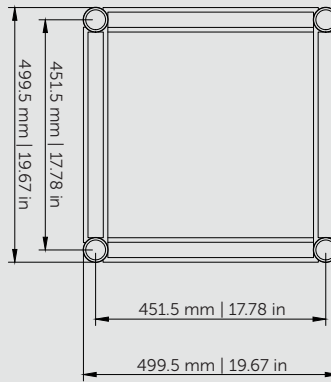

LOADING TABLES

		4 m	6 m	8 m	10 m	12 m	14 m	16 m	18 m	20 m	22 m	24 m
UDL [kg/m]		1467	670	369	230	154	108	79	58	44	33	25
Deflection [mm]		6	13	23	36	52	71	94	119	148	180	216
CPL [kg]		2657	1954	1476	1148	924	758	630	526	439	365	300
Deflection [mm]		4	10	19	30	43	59	79	102	128	158	192
TPL [kg]		1731	1318	1060	861	693	569	472	394	329	274	225
Deflection [mm]		4	11	22	35	48	63	78	93	106	117	125
QPL [kg]		1154	878	707	574	462	379	315	263	220	182	150
Deflection [mm]		4	11	20	32	45	58	72	86	99	109	116
FPL [kg]		921	708	573	478	385	316	262	219	183	152	125
Deflection		4	11	21	34	48	62	77	91	105	116	123
		13.12 ft	19.69 ft	26.25 ft	32.81 ft	39.37 ft	45.93 ft	52.49 ft	59.06 ft	65.62 ft	72.18 ft	78.74 ft
UDL [lbs/ft]		985.78	450.22	247.96	154.55	103.48	72.57	53.09	38.97	29.57	22.17	16.80
Deflection [in]		0.24	0.51	0.91	1.42	2.05	2.80	3.70	4.69	5.83	7.09	8.50
CPL [lbs]		5857.68	4307.83	3254.02	2530.91	2037.07	1671.10	1388.91	1159.63	967.83	804.69	661.39
Deflection [in]		0.16	0.39	0.75	1.18	1.69	2.32	3.11	4.02	5.04	6.22	7.56
TPL [lbs]		3816.20	2905.69	2336.90	1898.18	1527.80	1254.43	1040.58	868.62	725.32	604.07	496.04
Deflection [in]		0.16	0.43	0.87	1.38	1.89	2.48	3.07	3.66	4.17	4.61	4.92
QPL [lbs]		2544.13	1935.66	1558.67	1265.45	1018.54	835.55	694.46	579.82	485.02	401.24	330.69
Deflection [in]		0.16	0.43	0.79	1.26	1.77	2.28	2.83	3.39	3.90	4.29	4.57
FPL [lbs]		2030.46	1560.87	1263.25	1053.81	848.78	696.66	577.61	482.81	403.45	335.10	275.58
Deflection [in]		0.16	0.43	0.83	1.34	1.89	2.44	3.03	3.58	4.13	4.57	4.84

Loading tables are valid for static loads and spans with two supporting points. Spans must be supported at each end. Contact structural engineer if there are more supporting points applied or dynamic and wind loads involved.

STRAIGHT SEGMENT LENGTHS

Code	Length		Weight	
GS500N-100	1 m	3.28 ft	17.73 kg	39.09 lbs
GS500N-150	1.5 m	4.92 ft	27.30 kg	60.19 lbs
GS500N-200	2 m	6.56 ft	31.48 kg	69.39 lbs
GS500N-300	3 m	9.84 ft	45.09 kg	99.41 lbs

All other corner variants are available on request.

SPECIFICATIONS

Tubes	48 x 4.5 mm (1.89 x 0.18 in)
Braces	30 x 3 mm (1.2 x 0.12 in)
Alloy	EN AW-6082 T6

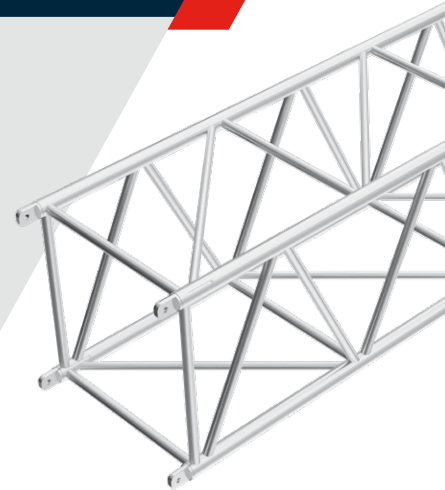
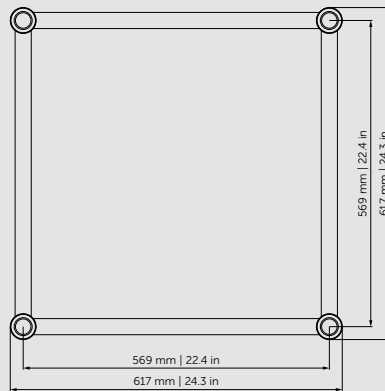

LOADING TABLES

		4 m	6 m	8 m	10 m	12 m	14 m	16 m	17 m	18 m	19 m	20 m
UDL [kg/m]		1657	1076	603	383	264	190	142	124	109	97	86
Deflection [mm]		4	13.2	23.7	37.3	54.1	73.9	96.7	109.3	122.7	136.9	151.9
CPL [kg]		4702	3227	2412	1916	1583	1331	1138	1058	985	920	860
Deflection [mm]		4.5	10.6	19.1	30.1	43.9	60.2	79.3	89.9	101.2	113.3	126.2
TPL [kg]		3315	2421	1809	1437	1188	998	854	793	739	690	645
Deflection [mm]		5.4	13.5	24.2	38.1	55.3	75.4	98.6	111.4	125.1	139.5	154.8
QPL [kg]		2210	1614	12.6	958	792	666	569	529	493	460	430
Deflection [mm]		5.1	12.6	22.5	35.5	51.6	70.4	92.3	104.4	117.3	131	145.5
FPL [kg]		1657	1345	1005	799	660	555	474	441	411	383	358
Deflection		4.9	13.4	24.1	37.9	55	75	98.2	111	124.5	138.9	134.1
		13.12 ft	19.68 ft	26.24 ft	32.8 ft	39.36 ft	45.92 ft	52.48 ft	55.76 ft	59.04 ft	62.32 ft	65.6 ft
UDL [lbs/ft]		1113.45	723.04	405.20	257.36	177.40	127.67	95.42	83.32	73.24	65.18	57.79
Deflection [in]		0.16	0.52	0.93	1.47	2.13	2.91	3.81	4.30	4.83	5.39	5.98
CPL [lbs]		10366.14	7114.32	5317.55	4224.06	3489.92	2934.35	2508.86	2332.49	2171.55	2028.25	1895.98
Deflection [in]		0.18	0.42	0.75	1.19	1.73	2.37	3.12	3.54	3.98	4.46	4.97
TPL [lbs]		7308.32	5337.39	3988.16	3168.04	2619.09	2200.21	1882.75	1748.27	1629.22	1521.19	1421.98
Deflection [in]		0.21	0.53	0.95	1.50	2.18	2.97	3.88	4.39	4.93	5.49	6.09
QPL [lbs]		4872.22	3558.26	27.78	2112.03	1746.06	1468.28	1254.43	1166.25	1086.88	1014.13	947.99
Deflection [in]		0.20	0.50	0.89	1.40	2.03	2.77	3.63	4.11	4.62	5.16	5.73
FPL [lbs]		3653.06	2965.22	2215.65	1761.49	1455.05	1223.57	1044.99	972.24	906.10	844.37	789.25
Deflection [in]		0.19	0.53	0.95	1.49	2.17	2.95	3.87	4.37	4.90	5.47	5.28

Loading tables are valid for static loads and spans with two supporting points. Spans must be supported at each end. Contact structural engineer if there are more supporting points applied or dynamic and wind loads involved.

STRAIGHT SEGMENT LENGTHS

Code	Length		Weight	
GS620-100	1 m	3.28 ft	17.83 kg	39.30 lbs
GS620-120	1.2 m	3.94 ft	19.39 kg	42.76 lbs
GS620-200	2 m	6.56 ft	26.58 kg	58.60 lbs
GS620-240	2.4 m	7.87 ft	33.71 kg	74.31 lbs
GS620-300	3 m	9.84 ft	37.25 kg	82.11 lbs
GS620-400	4 m	13.12 ft	53.49 kg	117.93 lbs

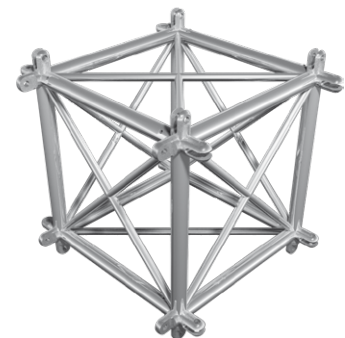

All other corner variants are available on request.

GS620-C41

	Four-way corner
	23.84 kg (52.56 lbs)

SPECIFICATIONS

Tubes	60 x 5 mm (2.36 x 0.18 in)
Braces	40 x 3 mm (1.57 x 0.12 in)
Alloy	EN AW-6082 T6

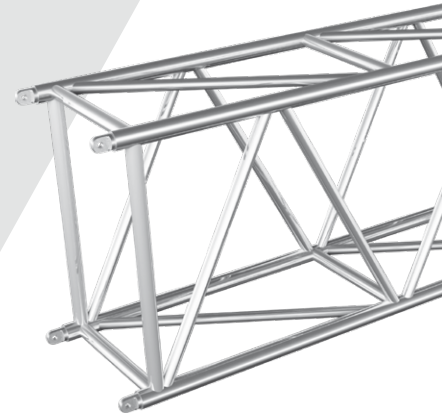
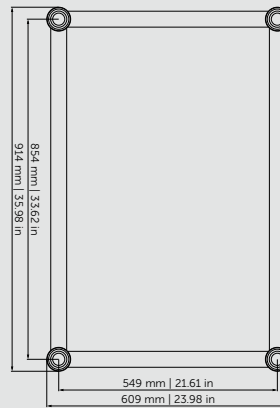

LOADING TABLES

		4 m	6 m	8 m	10 m	12 m	14 m	16 m	17 m	18 m	19 m	20 m
UDL [kg/m]		1870	1241	927	738	603	439	332	292	259	230	206
Deflection [mm]		1.4	4.8	11.4	22.3	38.1	51.9	67.8	76.6	86	95.8	106.3
CPL [kg]		7514	7388	5511	4378	3618	3070	2654	2482	2327	2188	2062
Deflection [mm]		2.3	7.6	13.6	21.2	30.7	41.9	55	62.2	69.9	78.1	86.8
TPL [kg]		3740	3723	3706	3284	2713	2302	1991	1861	1745	1641	1547
Deflection [mm]		1.9	6.5	15.5	27	38.9	53	69.2	78.2	87.7	97.8	108.5
QPL [kg]		2493	2482	2471	2189	1809	1535	1327	1241	1164	1094	1031
Deflection [mm]		1.8	6.1	14.4	25.1	36.2	49.4	64.6	73	82	91.4	101.4
FPL [kg]		1870	1862	1853	1824	1507	1279	1106	1034	970	912	859
Deflection		1.7	5.9	13.9	26.9	38.7	52.7	68.9	77.9	87.3	97.4	108
		13.12 ft	19.68 ft	26.24 ft	32.8 ft	39.36 ft	45.92 ft	52.48 ft	55.76 ft	59.04 ft	62.32 ft	65.6 ft
UDL [lbs/ft]		1256.58	833.91	622.92	495.91	405.20	294.99	223.09	196.22	174.04	154.55	138.43
Deflection [in]		0.06	0.19	0.45	0.88	1.50	2.04	2.67	3.02	3.39	3.77	4.19
CPL [lbs]		16565.53	16287.75	12149.68	9651.84	7976.32	6768.19	5851.07	5471.87	5130.16	4823.71	4545.93
Deflection [in]		0.09	0.30	0.54	0.83	1.21	1.65	2.17	2.45	2.75	3.07	3.42
TPL [lbs]		8245.29	8207.81	8170.33	7239.98	5981.14	5075.04	4389.40	4102.80	3847.07	3617.79	3410.55
Deflection [in]		0.07	0.26	0.61	1.06	1.53	2.09	2.72	3.08	3.45	3.85	4.27
QPL [lbs]		5496.12	5471.87	5447.62	4825.92	3988.16	3384.10	2925.53	2735.94	2566.18	2411.86	2272.97
Deflection [in]		0.07	0.24	0.57	0.99	1.43	1.94	2.54	2.87	3.23	3.60	3.99
FPL [lbs]		4122.64	4105.01	4085.17	4021.23	3322.37	2819.71	2438.31	2279.58	2138.48	2010.62	1893.77
Deflection [in]		0.07	0.23	0.55	1.06	1.52	2.07	2.71	3.07	3.44	3.83	4.25

Loading tables are valid for static loads and spans with two supporting points. Spans must be supported at each end. Contact structural engineer if there are more supporting points applied or dynamic and wind loads involved.

STRAIGHT SEGMENT LENGTHS

Code	Length		Weight	
GS910-100	1 m	3.28 ft	25.6 kg	56.48 lbs
GS910-120	1.2 m	3.94 ft	43.1 kg	95.07 lbs
GS910-200	2 m	6.56 ft	51.0 kg	112.42 lbs
GS910-240	2.4 m	7.87 ft	59.6 kg	131.32 lbs
GS910-250	2.5 m	8.20 ft	50.96 kg	112.35 lbs
GS910-300	3 m	9.84 ft	56.80 kg	125.22 lbs
GS910-400	4 m	13.12 ft	72.67 kg	160.21 lbs

All other corner variants are available on request.

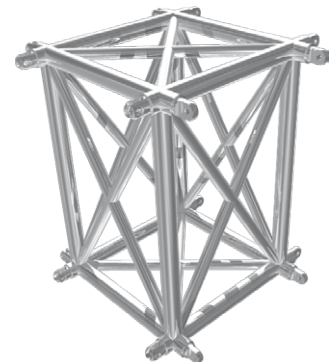

GS910-MCB

- Multi connection cube
- 22.54 kg (49.66 lbs)

SPECIFICATIONS

Tubes	48 x 4.5 mm (1.89 x 0.18 in)
Braces	25 x 3 mm (0.98 x 0.12 in)
Alloy	EN AW-6082 T6

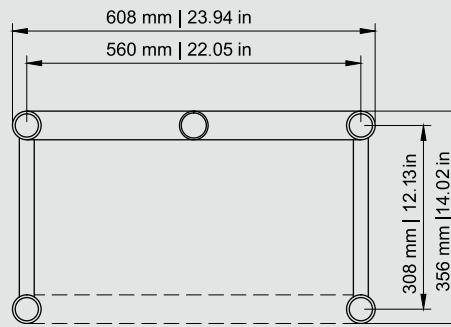

LOADING TABLES LC1 - LOADING OF THE TRUSS

		6 m	8 m	10 m	12 m	14 m	16 m	18 m	20 m
UDL [kg/m]		589	325	204	137	97	72	54	41
Deflection [mm]		24.9	44.4	69.5	100.4	137.2	179.9	228.7	283.7
CPL [kg]		1766	1302	1018	824	682	573	484	411
Deflection [mm]		20.1	35.9	56.6	82.3	113.3	150.0	192.6	241.8
		19.69 ft	26.25 ft	32.81 ft	39.37 ft	45.93 ft	52.49 ft	59.06 ft	65.62 ft
UDL [lbs/ft]		395.79	218.39	137.08	92.06	65.18	48.38	36.29	27.55
Deflection [in]		0.08	0.15	0.23	0.33	0.45	0.59	0.75	0.93
CPL [lbs]		3893.4	2870.4	2244.3	1816.6	1503.6	1263.2	1067.0	906.1
Deflection [in]		0.8	1.4	2.2	3.2	4.5	5.9	7.6	9.5

LOADING TABLES LC2 - LOADING AT CENTER TUBE

		6 m	8 m	10 m	12 m	14 m	16 m	18 m	20 m
UDL [kg/m]		450	325	203	137	97	72	54	41
Deflection [mm]		19.2	44.4	69.5	100.4	137.1	179.8	228.5	283.5
CPL [kg]		420	420	420	420	420	420	420	411
Deflection [mm]		5.2	12.9	26.0	46.6	76.5	118.0	173.5	241.6
		19.69 ft	26.25 ft	32.81 ft	39.37 ft	45.93 ft	52.49 ft	59.06 ft	65.62 ft
UDL [lbs/ft]		302.39	218.39	136.41	92.06	65.18	48.38	36.29	27.55
Deflection [in]		0.76	1.75	2.74	3.95	5.40	7.08	9.00	11.16
CPL [lbs]		925.94	925.94	925.94	925.94	925.94	925.94	925.94	906.10
Deflection [in]		0.20	0.51	1.02	1.83	3.01	4.65	6.83	9.51

Loading tables are valid for static loads and spans with two supporting points. Spans must be supported at each end. Contact structural engineer if there are more supporting points applied or dynamic and wind loads involved.



STRAIGHT SEGMENT LENGTHS

Code	Length		Weight	
PR1-120	1.20 m	3.94 ft	23.82 kg	52.50 lbs
PR1-240	2.40 m	7.87 ft	35.01 kg	77.17 lbs







PR1-120B

 Straight segment,
black coating
 1.2 m (3.94 ft)
 23.82 kg (52.50 lbs)





PR1-240B

 Straight segment,
black coating
 2.4 m (7.87 ft)
 35.01 kg (77.17 lbs)





PR1-D-120

 Dolly
 1.2 m (3.94 ft)
 14.65 kg (32.29 lbs)



PR1-D-240

 Dolly
 2.4 m (7.87 ft)
 17.41 kg (38.37 lbs)

Fork Connectors

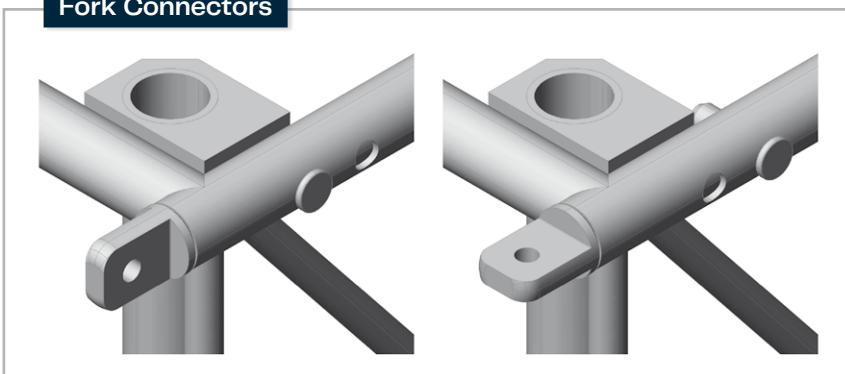

Pre-Rig Truss features male/female fork connectors that can be positioned vertically or horizontally to allow for more versatile connections.

DETAILED DESCRIPTION OF PR1 – PRE-RIG TRUSS



PR1-120 / PR1-240

- Available in different lengths
120 cm (3.94 ft) / 240 cm (7.87 ft)
- Fork connection – two positions
- Powder coating on request

PR1-D-120 / PR1-D-240

- Available in different lengths
120 cm (3.94 ft) / 240 cm (7.87 ft)
- Durable dolly
- Powder coating on request

Easily stackable

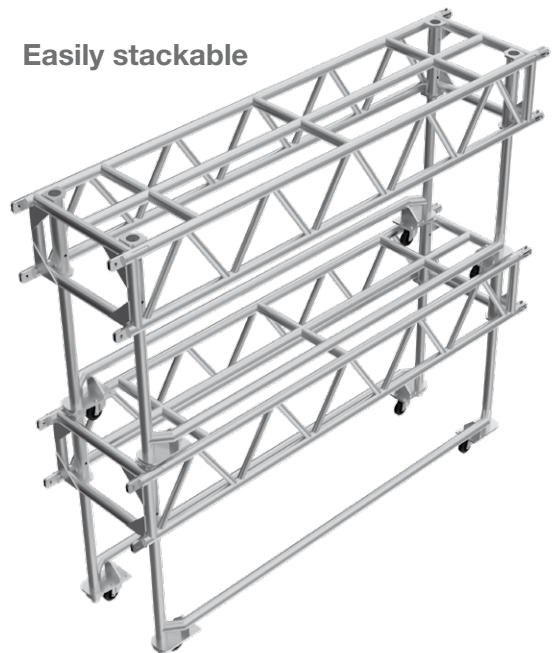

Front view

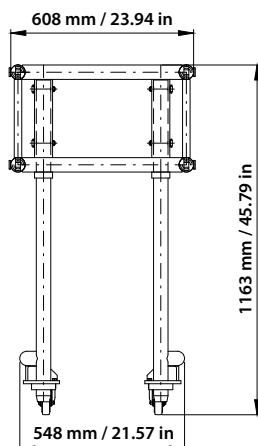

Side view

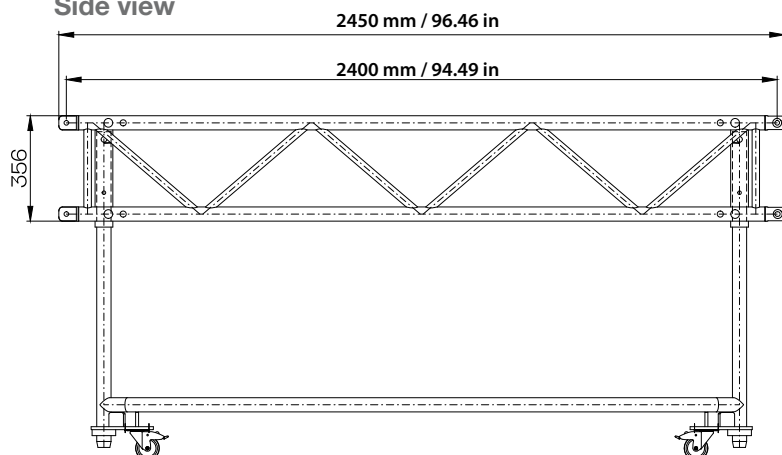

SPECIFICATIONS

Tubes	50 x 4 mm (1.97 x 0.16 in)
Braces	25 x 3 mm (0.98 x 0.12 in)
Alloy	EN AW-6082 T6

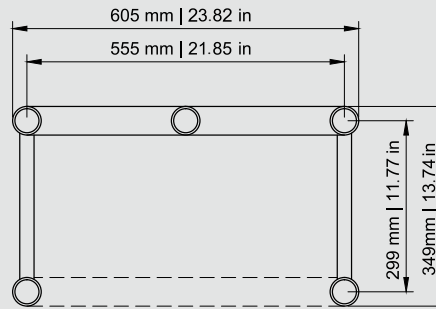

LOADING TABLES LC1 - LOADING OF THE TRUSS

		6 m	8 m	10 m	12 m	14 m	16 m	18 m	20 m
UDL [kg/m]		568	319	206	139	99	71	53	39
Deflection [mm]		27.2	49.2	79.1	114.3	155.9	201.1	253.1	305.2
CPL [kg]		1704	1278	1028	834	690	569	475	388
Deflection [mm]		21.9	39.8	64.3	93.6	128.6	167.6	213.2	260.5
		19.69 ft	26.25 ft	32.81 ft	39.37 ft	45.93 ft	52.49 ft	59.06 ft	65.62 ft
UDL [lbs/ft]		381.68	214.36	138.43	93.40	66.52	47.71	35.61	26.21
Deflection [in]		0.09	0.16	0.26	0.38	0.51	0.66	0.83	1.00
CPL [lbs]		3756.68	2817.51	2266.35	1838.66	1521.19	1254.43	1047.20	855.40
Deflection [in]		0.86	1.57	2.53	3.69	5.06	6.60	8.39	10.26

LOADING TABLES LC2 - LOADING AT CENTER TUBE

		6 m	8 m	10 m	12 m	14 m	16 m	18 m	20 m
UDL [kg/m]		568	319	206	139	99	71	53	39
Deflection [mm]		27.2	49.2	79.1	114.3	155.9	201.1	253.1	305.2
CPL [kg]		520	520	520	520	520	520	475	388
Deflection [mm]		7.1	17.4	35.0	62.3	101.8	156.1	213.2	260.5
		19.69 ft	26.25 ft	32.81 ft	39.37 ft	45.93 ft	52.49 ft	59.06 ft	65.62 ft
UDL [lbs/ft]		381.68	214.36	138.43	93.40	0.51	47.71	35.61	26.21
Deflection [in]		0.09	0.16	0.26	0.38	5.40	0.66	0.83	1.00
CPL [lbs]		1146.40	1146.40	1146.40	1146.40	1146.40	1146.40	1047.20	855.39
Deflection [in]		0.28	0.69	1.38	2.45	4.01	6.15	8.39	10.26

Loading tables are valid for static loads and spans with two supporting points. Spans must be supported at each end. Contact structural engineer if there are more supporting points applied or dynamic and wind loads involved.

STRAIGHT SEGMENT LENGTHS

Code	Length		Weight	
PR2-122	1.22 m	4.00 ft	32.00 kg	70.55 lbs
PR2-244	2.44 m	8.00 ft	45.00 kg	99.21 lbs

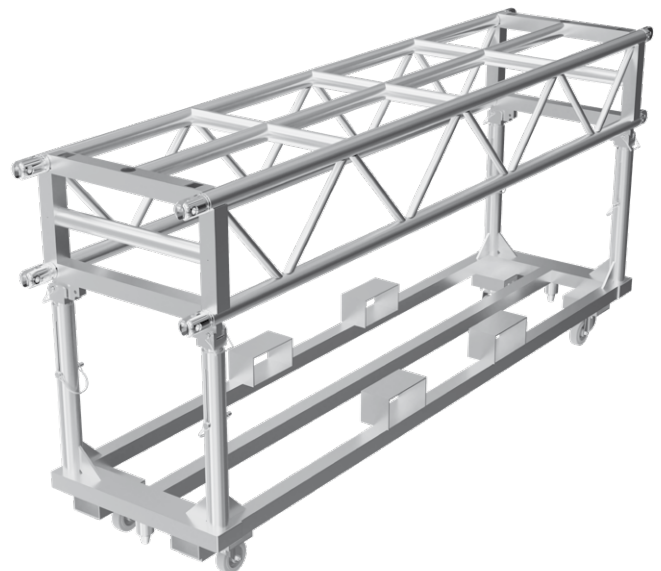

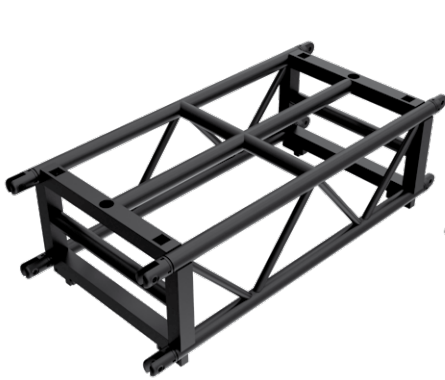

PR2 Pre-Rig Truss

FORK TRUSS





PR2-122B

 Straight segment,
black coating
 1.22 m (4.00 ft)
 32.00 kg (70.55 lbs)





PR2-244B

 Straight segment,
black coating
 2.44 m (8.00 ft)
 45.00 kg (99.21 lbs)



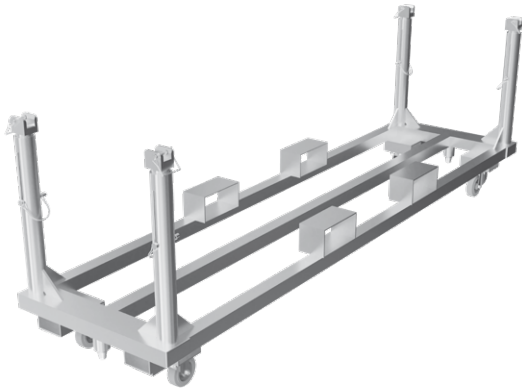

PR2-D-122

 Dolly
 1.22 m (4.00 ft)
 17.97 kg (39.61 lbs)



PR2-D-244

 Dolly
 2.44 m (8.00 ft)
 25.14 kg (55.43 lbs)

Fork Connectors

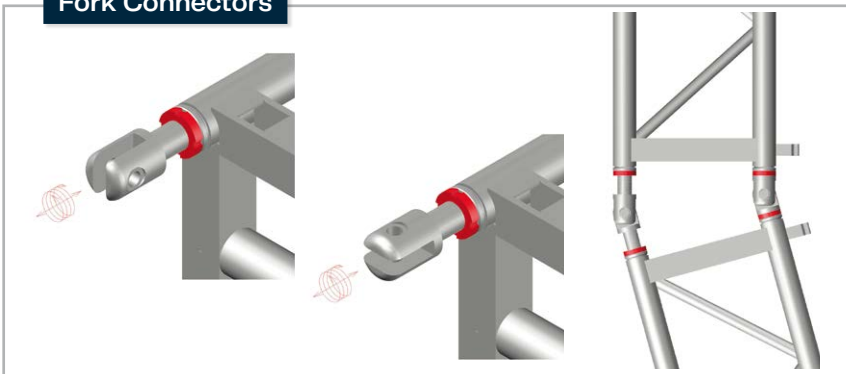

This model has threaded connectors that can be extended up to 65 mm (2.56 in) from the tube, which can then be secured with a safety ring. 0° - 12° angles can be achieved, without the need for additional corners or other accessories.

DETAILED DESCRIPTION OF PR2 – PRE-RIG TRUSS

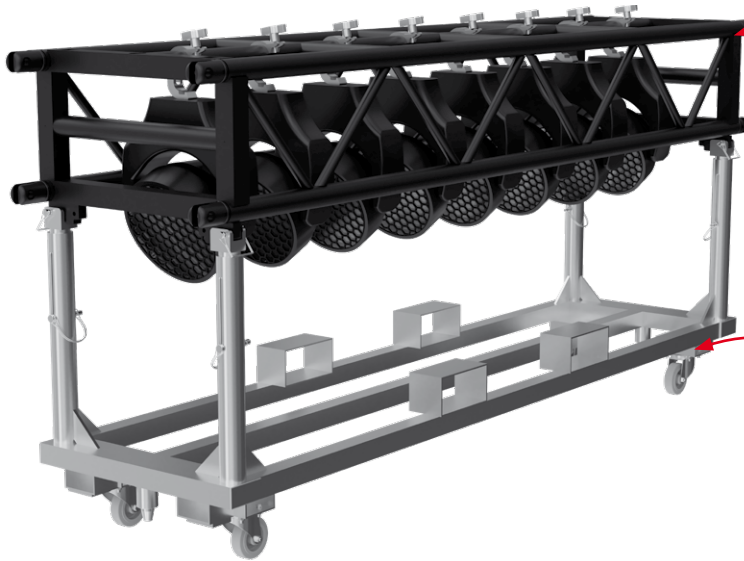

PR2-122 / PR2-244

- Available in different lengths
122 cm (4 ft) / 244 cm (8 ft)
- Fork connection – two positions
- Powder coating on request

PR2-D-120 / PR2-D-240

- Available in different lengths
122 cm (4 ft) / 244 cm (8 ft)
- Durable dolly
- Powder coating on request

Easily stackable

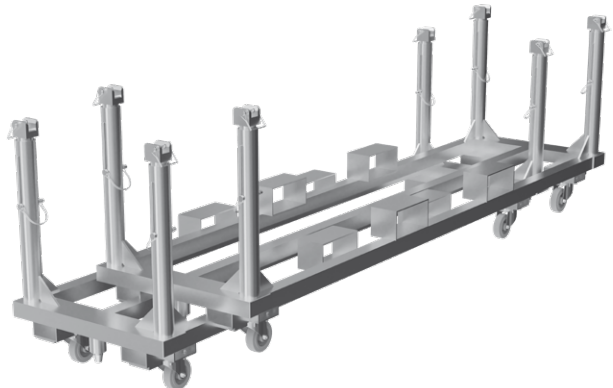

Front view

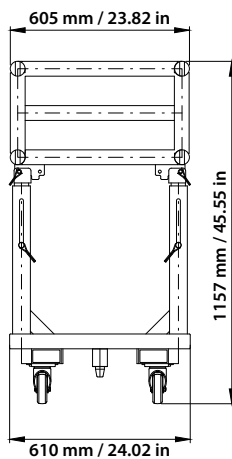

Side view

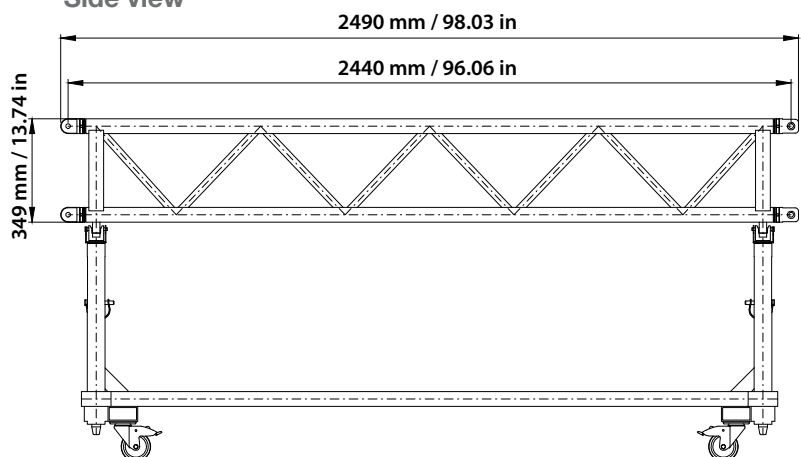



U-Frame Design
The center point load of each unit is max. 50 kg (110 lbs) in stable design configuration.

U-Frame Ladder
For ladder set up it is possible to hang max. 10 U-Frame units beneath each other without any extra rigging needed.

TAF U-Frames are the best fit for your rigging and lighting needs. U-Frames are constructed from TAF's standard single pipes 50 x 2 mm (1.97 x 0.08 in) and accessories.

U-60 LENGTHS

Code	Length	Weight
U-60/55	0.55 m (1.80 ft)	2.03 kg (4.48 lbs)
U-60/65	0.65 m (2.13 ft)	2.19 kg (4.83 lbs)
U-60/70	0.70 m (2.30 ft)	2.27 kg (5.00 lbs)
U-60/76	0.76 m (2.49 ft)	2.37 kg (5.23 lbs)
U-60/80	0.80 m (2.62 ft)	2.44 kg (5.38 lbs)
U-60/90	0.90 m (2.95 ft)	2.60 kg (5.73 lbs)
U-60/100	1.00 m (3.28 ft)	2.76 kg (6.09 lbs)



U-60

U-Frame base
50 x 2 mm (1.97 x 0.08 in)
0.6 m (1.97 ft)
According to length



U-60/T

Top bar for U-Frame
+ M12 eyes
50 x 2 mm (1.97 x 0.08 in)
0.6 m (1.97 ft)
2.44 kg (5.38 lbs)



U-60/TC1

Top bar for U-Frame
+ 8001 clamps
50 x 2 mm (1.97 x 0.08 in)
0.6 m (1.97 ft)
3.12 kg (7.08 lbs)

U-75 LENGTHS

Code	Length	Weight
U-75/80	0.80 m (2.62 ft)	2.56 kg (5.64 lbs)
U-75/90	0.90 m (2.95 ft)	2.72 kg (6.00 lbs)



U-75

U-Frame base
 50 x 2 mm (1.97 x 0.08 in)
 0.75 m (2.46 ft)

U-75/T

Top bar for U-Frame
 + M12 eyes
 50 x 2 mm (1.97 x 0.08 in)
 0.75 m (2.46 ft)
 2.56 kg (5.64 lbs)

Key benefits:

- Quicklock (conical, spigoted) connectors for quick and easy assembly
- Stackable, for convenient transport
- Can be extended by any FT31 truss product or accessories
- Highly modular
- Available in any RAL colour on request



U-80

U-Frame base
 50 x 2 mm (1.97 x 0.08 in)
 1.00 m (3.28 ft)
 2.93 kg (6.46 lbs)

U-80/T

Top bar for U-Frame
 + M12 eyes
 50 x 2 mm (1.97 x 0.08 in)
 0.80 m (2.62 ft)
 2.60 kg (5.73 lbs)



U-80A/110H



Adjustable U-Frame base
 50 x 3 mm (1.97 x 0.12 in)
 0.80 m (2.62 ft)
 5.08 kg (11.20 lbs)

QUICKLOCK LINE

U-FRAMES





U-90/100H

 U-Frame base
50 x 3 mm (1.97 x 0.12 in)
 0.90 m (2.95 ft)
 2.93 kg (6.46 lbs)





U-90/T

 Top bar for U-Frame
+ M12 eyes
50 x 3 mm (1.97 x 0.12 in)
 0.90 m (2.95 ft)
 2.68 kg (5.91 lbs)



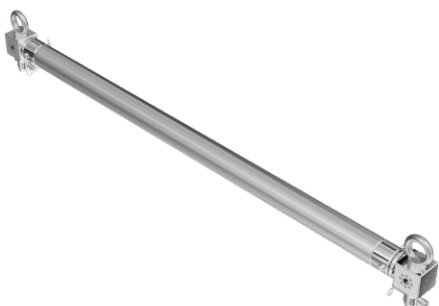

U-110/1250

 U-Frame base
50 x 2 mm (1.97 x 0.08 in)
 1.10 m (3.61 ft)
 3.7 kg (8.16 lbs)



U-110/T

 Top bar for U-Frame
+ M12 eyes
50 x 2 mm (1.97 x 0.08 in)
 1.10 m (3.61 ft)
 2.85 kg (6.28 lbs)

VARIO PLATE 3010

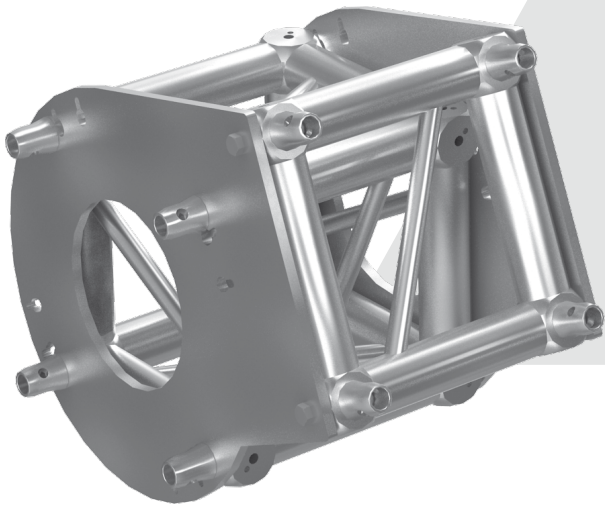

Vario Plate extends the versatility of FT34 and HT34 trussing lines and gives you the possibility to be more creative in the use of standard truss segments. An impressive range of arches can be achieved with standard 290 x 290 mm (11.42 x 11.42 in) trussing, without the need for any special corners. Vario Plate maximizes the modularity of your truss.

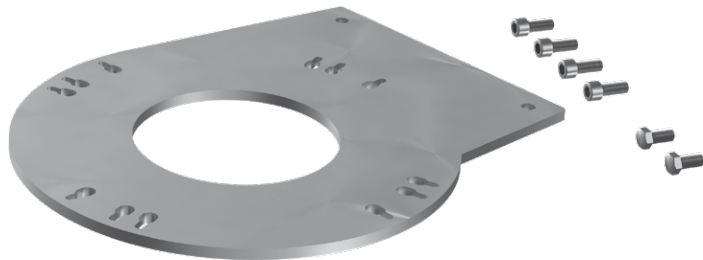

VARIO PLATE APPLICATION

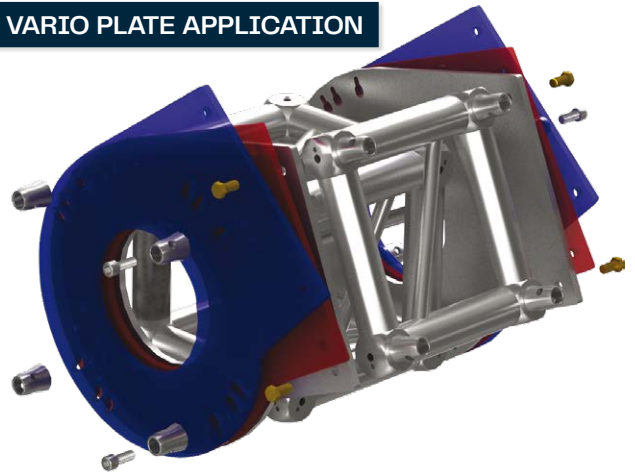

3010

Vario plate
45°, 60°, 67.5°

VARIO CORNER ASSEMBLY

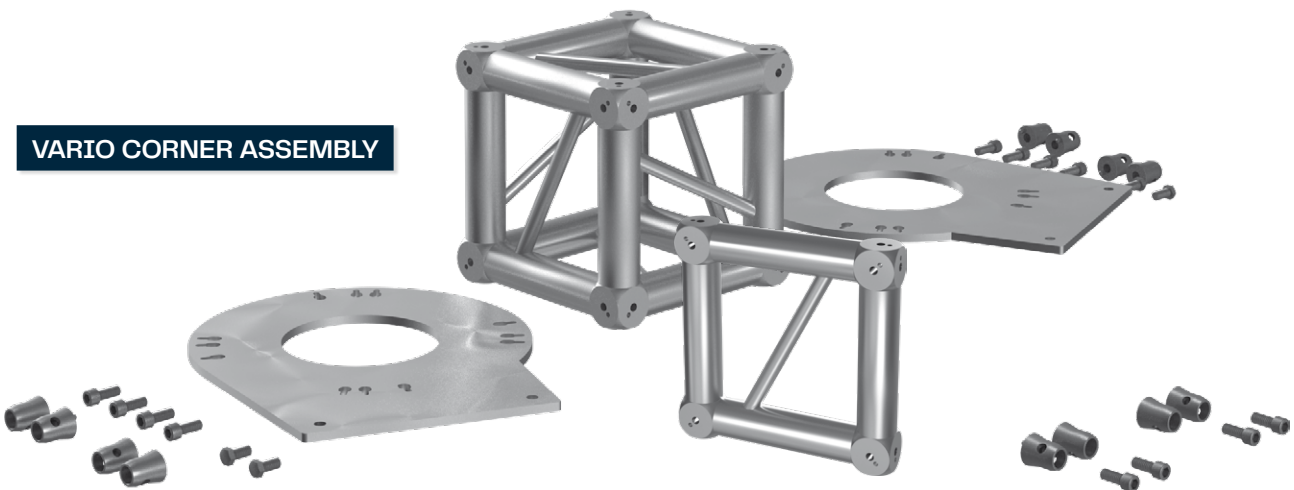

3116

4 pieces

FT34/HT34-MCB

1 piece

3116

4 pieces

3116

4 pieces

3010

1 piece

FT34-32F/HT34-32F

1 piece

3010

1 piece

CLAMPS

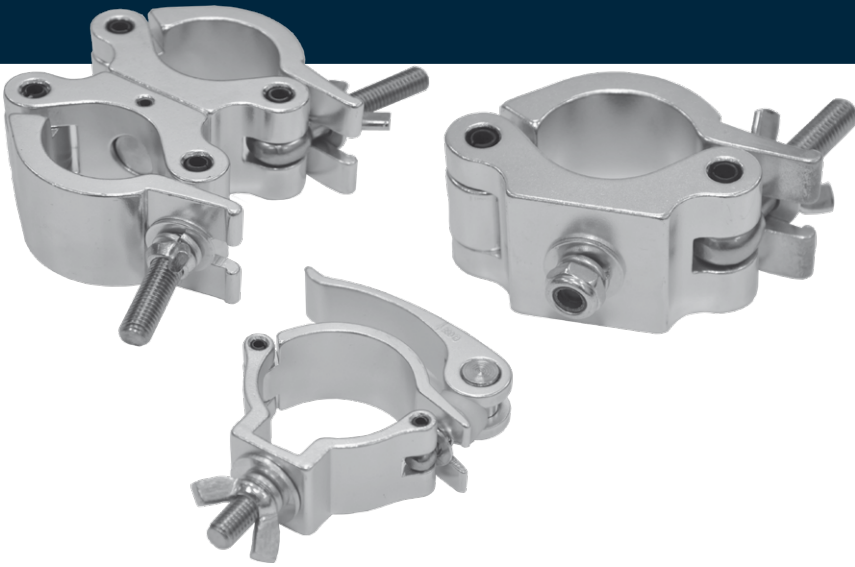

We offer wide range of clamps for securing lighting, pipes, and other materials to your truss. TAF clamps feature a modern design, attractive finish, and are TÜV certified. Clamps are “must have” accessories for any successful rigger, truss designer, or lighting professional. They are available with an aluminium finish or black powder coating as standard.

FOR LIGHT-DUTY TRUSSES (18-20 mm and 32-35 mm tube)

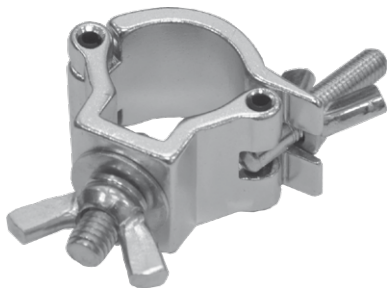

8014

Half Coupler M5
10 kg (22 lbs)
18-20 mm (0.71-0.79 in)
FT14



8014-B

Half Coupler M5 Black
10 kg (22 lbs)
18-20 mm (0.71-0.79 in)
FT14



8026

Swivel Coupler
10 kg (22 lbs)
18-20 mm (0.71-0.79 in)
FT14

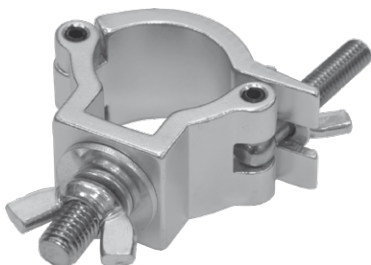

8005

Half Coupler Slim M10
75 kg (165 lbs)
32-35 mm (1.26-1.38 in)
FT21-FT24



8005-B

Half Coupler Slim M10 Black
75 kg (165 lbs)
32-35 mm (1.26-1.38 in)
FT21-FT24



8006

Swivel Coupler Slim
50 kg (110 lbs)
32-35 mm (1.26-1.38 in)
FT21-FT24



8006-B

Swivel Coupler Slim Black
50 kg (110 lbs)
32-35 mm (1.26-1.38 in)
FT21-FT24



8024

Exhibit Clamp Slim straight M8
32-35 mm (1.26-1.38 in)



8025

Exhibit Clamp Slim bent M8
32-35 mm (1.26-1.38 in)



8027

C-clamp M8
75 kg (165 lbs)
32-35 mm (1.26-1.38 in)
FT21-FT24

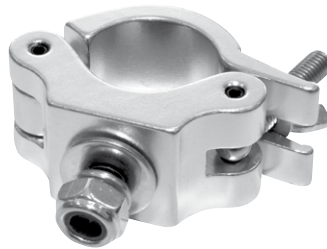

8028

Half Coupler M10
200 kg (440 lbs)
32-35 mm (1.3-1.4 in)
FT21-FT24

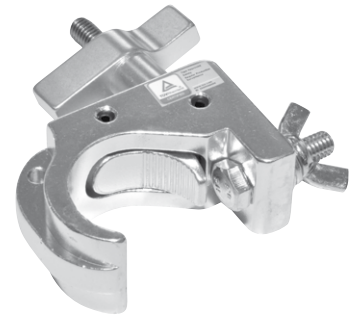

8029

Light Hook Coupler Slim M8
75 kg (165 lbs)
32-35 mm (1.3-1.4 in)
FT21-FT24

**FOR MEDIUM TO HEAVY-DUTY TRUSSES
(48-51 mm tube)**



8001

Half Coupler M10
500 kg (1,100 lbs)
48-51 mm (1.89-2.00 in)
FT31-TT74M



8001-B

Half Coupler M10 Black
500 kg (1,100 lbs)
48-51 mm (1.89-2.00 in)
FT31-TT74M



8002

Half Coupler Slim M10
200 kg (440 lbs)
48-51 mm (1.89-2.00 in)
FT31-TT74M

CLAMPS



8002-B

Half Coupler Slim M10 Black
200 kg (440 lbs)
48-51 mm (1.89-2.00 in)
FT31-TT74M

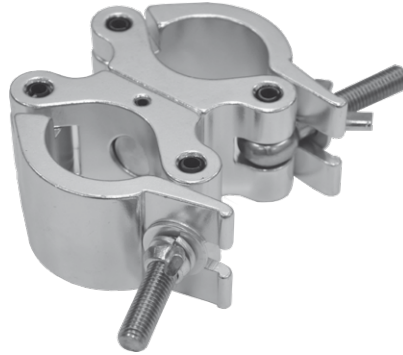

8003

Swivel Coupler
500 kg (1,100 lbs)
48-51 mm (1.89-2.00 in)
FT31-TT74M



8003-B

Swivel Coupler Black
500 kg (1,100 lbs)
48-51 mm (1.89-2.00 in)
FT31-TT74M



8004

C-Clamp Slim M10
250 kg (551 lbs)
48-51 mm (1.89-2.00 in)
FT31-TT74M



8004-B

C-Clamp Slim M10 Black
250 kg (551 lbs)
48-51 mm (1.89-2.00 in)
FT31-TT74M

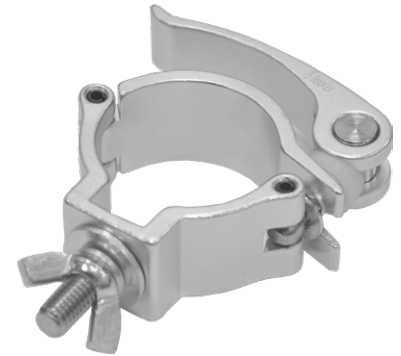

8007

Quick Half Coupler Slim
100 kg (220 lbs)
48-51 mm (1.89-2.00 in)
FT31-TT74M



8007-B

Quick Half Coupler Slim M10
Black
100 kg (220 lbs)
48-51 mm (1.89-2.00 in)
FT31-TT74M

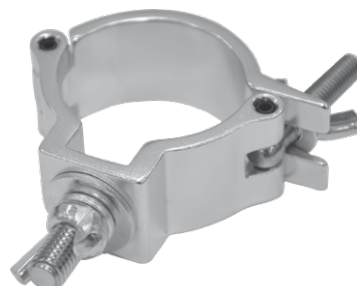

8011

Half Coupler Slim-Light M8
100 kg (220 lbs)
48-51 mm (1.89-2.00 in)
FT31-TT74M



8011-B

Half Coupler Slim-Light M8
Black
100 kg (220 lbs)
48-51 mm (1.89-2.00 in)
FT31-TT74M



8015

Swivel Coupler Slim-Light
100 kg (220 lbs)
48-51 mm (1.89-2.00 in)
FT31-TT74M



8015-B

Swivel Coupler Slim-Light Black
100 kg (220 lbs)
48-51 mm (1.89-2.00 in)
FT31-TT74M



8016

Quick Selflock Coupler Slim
250 kg (551 lbs)
48-51 mm (1.89-2.00 in)
FT31-TT74M



8016-B

Quick Selflock Coupler Slim
Black
250 kg (551 lbs)
48-51 mm (1.89-2.00 in)
FT31-TT74M



8017

Half Coupler M10 + Eye Bolt
200 kg (440 lbs)
48-51 mm (1.89-2.00 in)
FT31-TT74M

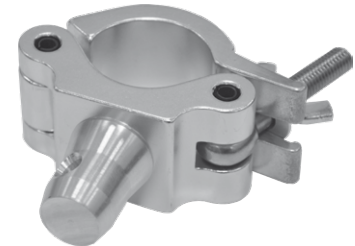

8018

Half Coupler M10 +
Halfconnector
48-51 mm (1.89-2.00 in)
FT31-TT74M

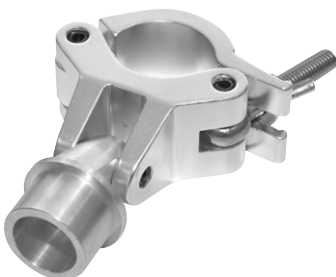

8019

Stabiliser Clamp
48-51 mm (1.89-2.00 in)
50 x 4 mm / 48 x 3 mm
(1.97 x 0.16 in / 1.89 x 0.12 in)



8020

Side Clamp M10
48-51 mm (1.89-2.00 in)
FT31-TT74M



8021

Exhibit clamp straight M8
500 kg (1,100 lbs)
48-51 mm (1.89-2.00 in)
FT31-TT74M

CLAMPS



8023

Exhibit clamp bent M8
500 kg (1,100 lbs)
48-51 mm (1.89-2.00 in)
FT31-TT74M



8031

Side Clamp Slim + Halfconnector
M10
300 kg (660 lbs)
48-51 mm (1.89-2.00 in)
FT31-TT74M



8032

Light Hook Coupler Slim
250 kg (551 lbs)
48-51 mm (1.89-2.00 in)
FT31-TT74M



8033

Swivel Coupler Slim
200 kg (440 lbs)
48-51 mm (1.89-2.00 in)
FT31-TT74M



8033-B

Swivel Coupler Slim Black
200 kg (440 lbs)
48-51 mm (1.89-2.00 in)
FT31-TT74M



8034

Half Coupler M12
750 kg (1,650 lbs)
48-51 mm (1.89-2.00 in)
FT31-TT74M



8035

Exhibit Clamp Slim bent M8
100 kg (220 lbs)
48-51 mm (1.89-2.00 in)
FT31-TT74M



8036

Exhibit Clamp Slim straight M8
100 kg (220 lbs)
48-51 mm (1.89-2.00 in)
FT31-TT74M

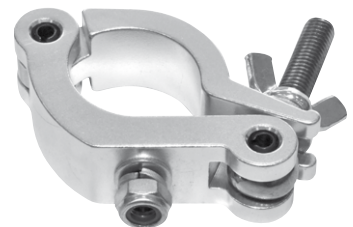

8037

Side Clamp Slim
300 kg (660 lbs)
48-51 mm (1.89-2.00 in)
FT31-TT74M

**FOR SUPER HEAVY-DUTY TRUSSES
(60 mm tube)**



8038

Half Coupler M12
750 kg (1,653 lbs)
60 mm (2.36 in)



8039

Swivel Coupler
750 kg (1,653 lbs)
60 mm (2.36 in)



8042

Swivel Coupler
500 kg (1,102 lbs)
50 mm (1.97 in), 60 mm (2.36 in)

OTHER CLAMPS



8102

Snap Clamp
Black
48-51 mm
(1.89-2.00 in)
FT31-TT74M



8103

Snap Clamp
Silver
48-51 mm
(1.89-2.00 in)
FT31-TT74M



8104

Snap Clamp
Black
48-51 mm
(1.89-2.00 in)
FT31-TT74M



8105

Snap Clamp
Silver
48-51 mm
(1.89-2.00 in)
FT31-TT74M



8106

Snap Stack Grey
48-51 mm (1.89-2.00 in) tubes
20 mm (0.79 in) brace



8107

Snap Stack Black
48-51 mm (1.89-2.00 in) tubes
20 mm (0.79 in) brace



8108

Snap Stack Grey
48-51 mm (1.89-2.00 in) tubes
16 mm (0.63 in) brace



8109

Snap Stack Black
48-51 mm (1.89-2.00 in) tubes
16 mm (0.63 in) brace



TOWERS

TAF Towers have wide range of applications. The two basic kinds of TAF tower systems are those that support various grids (e.g. in roof systems or large span structures) and those used as PA towers to support speakers.

TOWER 05

A light duty tower constructed from standard HT34 trussing. Tower 05 is the right choice for smaller set ups with lighter loading requirements. It is easy to transport and is extremely user-friendly. It comes with all components, including connection kit, for quick and successful installation.

TOWER 1

Tower 1 has various applications and is mostly used in TAF Roof 2 systems. However, there are no limits to its other applications, such as support for LED screens, roof wings, speaker support, etc.

TOWER 2

Tower 2 is a heavier duty version of the roof tower and can go up to 12 m (39.37 ft) high. It is a suitable option for larger roof systems at big concerts or festivals.

BOLTED TOWER TFTB-L

Our bolted, light-duty tower is perfect for use with standard 12 in (304.8 mm) bolted truss for a wide range of ground support that includes roof systems, LED support, and other support structures.

PA TOWER 05

PA Tower 05 is an attractive PA Tower for use at smaller events. It supports speakers up to 300 kg (661 lbs) and can go up to 6.3 m (21 ft) high. The PA Tower is constructed with standard FT34 trussing segments. It can be adjusted to accommodate various types of rigging motors.

PA TOWER 1

PA Tower 1 features relatively small dimensions and is the perfect choice for various kinds of applications, such as outdoor events, concerts, shopping malls, entrance halls, exhibitions, displays, theme parks, and corporate events.

PA Vertical Tower – PAV1

Our PA Vertical Tower 1 comes with a specially designed top section constructed from HT44 truss and can support up to 1000 kg (2,205 lbs) loads at up to 8 m (26.2 ft). It can serve as a part of stage setups or as stable support for LED walls.

TOWER 05



TOWER 05

A light-duty tower for smaller set ups. It is constructed with Quicklock HT34 trussing and comes with a hand winch, steel rope, and outriggers. It features a max. lifting height of 6.5 m (21.33 ft), with the possibility to lift up to 850 kg (1,874 lbs) loads. It is a perfect choice for building up smaller roof systems, LED support, strong lighting support, DJ booths, and more.

PART LIST

TOWER SET 05	1 pc
	- tower 05 base plate - tower 05 sleeve block - tower 05 top section - tower 05 hand winch - hinge section - safety hooks
HT34-150	2 pcs
HT34-200	1 pc

SPECIFICATIONS

SELF WEIGHT	100 kg (220.5 lbs)
HEIGHT	6.5 m (21.3 ft)
LOAD CAPACITY	850 kg (1,874 lbs)

HT34 MAST SECTION

MAIN TUBES	50 x 3 mm (1.97 x 0.12 in)
BRACES	20 x 2 mm (0.79 x 0.08 in)
ALLOY	EN AW-6082 T6

Transport, setup, and use are extremely easy. Just roll out to your location, unfold the outriggers, and attach HT34 truss on top. Versatility is also ensured, with a welded sleeve block that allows for four-way connection of truss segments to suit a wide range of applications.

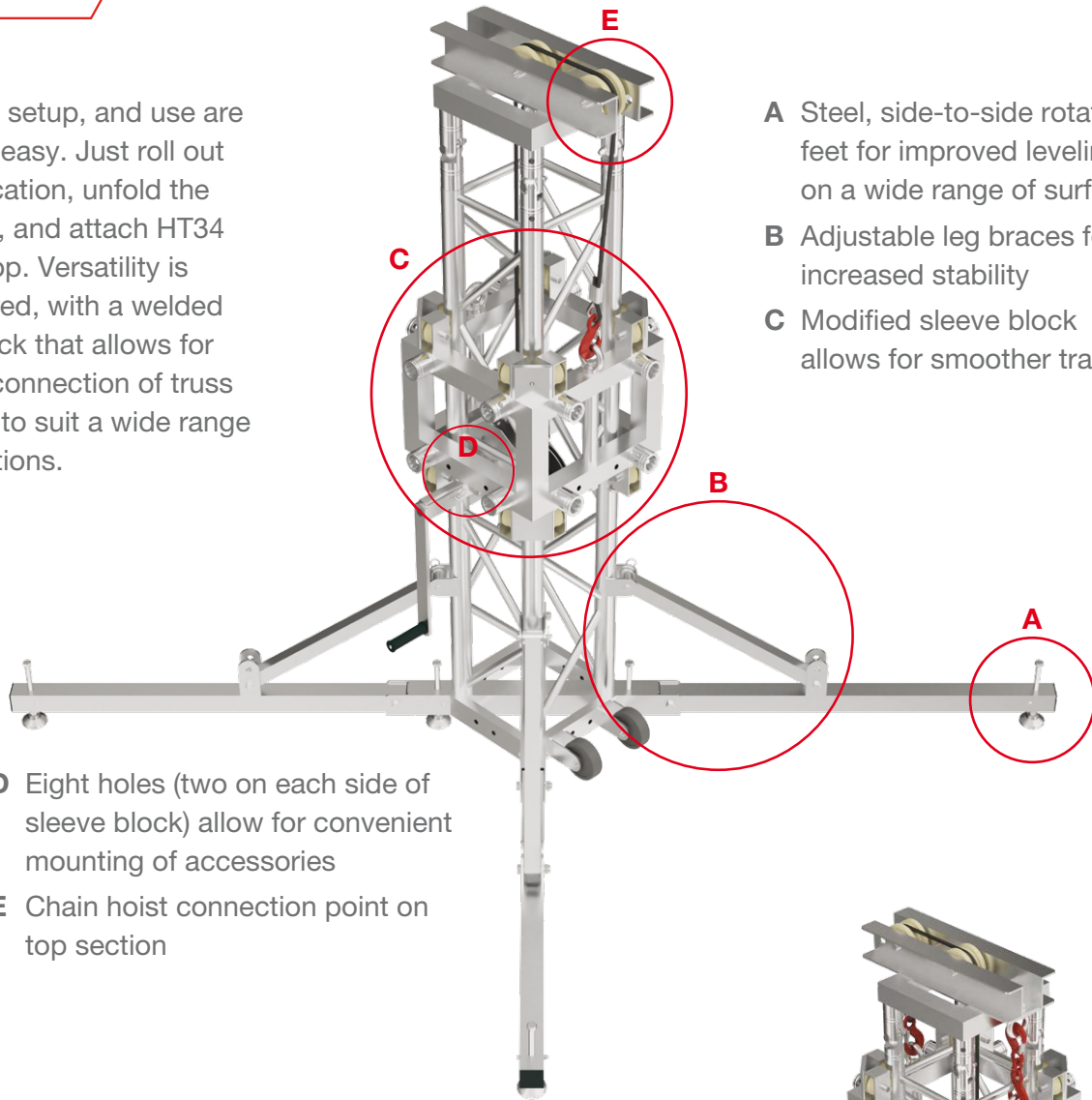

- A** Steel, side-to-side rotating feet for improved leveling on a wide range of surfaces
- B** Adjustable leg braces for increased stability
- C** Modified sleeve block allows for smoother travel

- D** Eight holes (two on each side of sleeve block) allow for convenient mounting of accessories
- E** Chain hoist connection point on top section



OPTIONAL ACCESSORIES

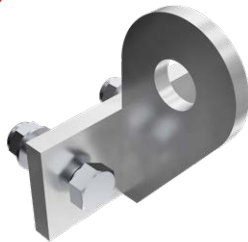

TO5T-BP-SWH

Safety wire hook for base plate
 100 x 105 x 90 mm
 (3.94 x 4.13 x 3.54 in)
 0.82 kg (1.80 lbs)



TO5T-SB-SWH

Safety wire hook for sleeve block
 160 x 128 x 10 mm
 (6.30 x 5.04 x 0.39 in)
 1.13 kg (2.49 lbs)



TO5T-SB-EB

Eyebold for sleeve block
 45 x 62 x 25 mm
 (1.77 x 2.44 x 0.98 in)
 0.11 kg (0.24 lbs)

TOWER 1



TOWER 1

Tower 1 is made from Quicklock truss segments. It can go up to 7.5 m (24.6 ft) high and features a maximum loading capacity of 1000 kg (2,205 lbs). This tower system can be used for a wide range of roof designs or as support for larger LED screens support. It can be equipped with a hand winch, manual chain hoist, or rigging motor.

PART LIST

T1T-BP	1 pc
T1T-LO	4 pcs
T1T-SBT44-2W	1 pc
T1T-TS-650+EB	1 pc
T1T-HS	4 pcs
T1T-CH1	1 pc
TT34-50	1 pc
TT34-200	2 pcs
TT34-300	1 pc
T1T-SH-700	1 pc

SPECIFICATIONS

SELF WEIGHT	190 kg (419 lbs)
HEIGHT	7.5 m (24.6 ft)
LOAD CAPACITY	1000 kg (2,205 lbs)

TT34 MAST SECTION

MAIN TUBES	50 x 4 mm (1.97 x 0.16 in)
BRACES	20 x 2 mm (0.79 x 0.08 in)
ALLOY	EN AW-6082 T6



T1T-BP

Steel base plate
680 x 680 x 340 mm
(26.77 x 26.77 x 13.39 in)
33.42 kg (73.68 lbs)

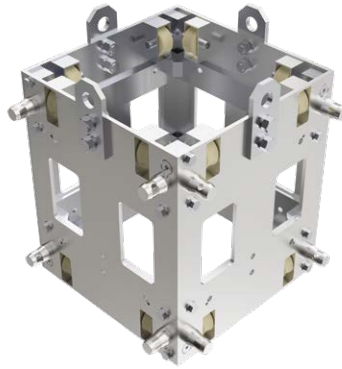

T1T-SBT44-2W

Sleeve block
467 x 530 x 467 mm
(18.39 x 20.87 x 18.39 in)
49.41 kg (109.93 lbs)



T1T-TS-650+EB

Top section
650 x 260 x 290 mm
(25.59 x 10.24 x 11.42 in)
12.88 kg (28.4 lbs)



T1T-LO

Long outrigger
1520 x 110 x 340 mm
(595.84 x 4.33 x 13.39 in)
10.92 kg (24.06 lbs)



T1T-HS

Hinge section
49 x 166 x 66 mm
(1.93 x 6.54 x 2.60 in)
0.61 kg (1.33 lbs)



T1T-SH-700

Safety hooks - 700 mm,
hook + hook
750 x 60 x 75 mm
(29.53 x 2.36 x 2.95 in)
1.15 kg (2.54 lbs)

OPTIONAL ACCESSORIES



T1T-BF

Ballast frame, 2000 kg (4,409 lbs)
1220 x 1505.5 x 105 mm
(48.03 x 59.25 x 4.13 in)
31.04 kg (68.43 lbs)



T1T-SO

Short outrigger
405 x 340 x 110 mm
(15.94 x 13.39 x 4.33 in)
3.97 kg (8.74 lbs)

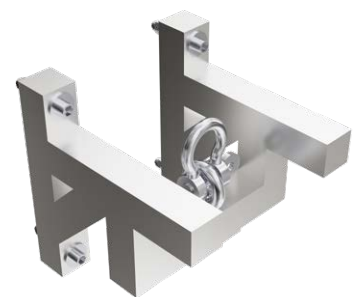

T1T-MH-SB

Motor holder on sleeve block
289 x 290 x 300 mm
(11.38 x 11.42 x 11.81 in)
5.65 kg (12.48 lbs)

TOWER 2

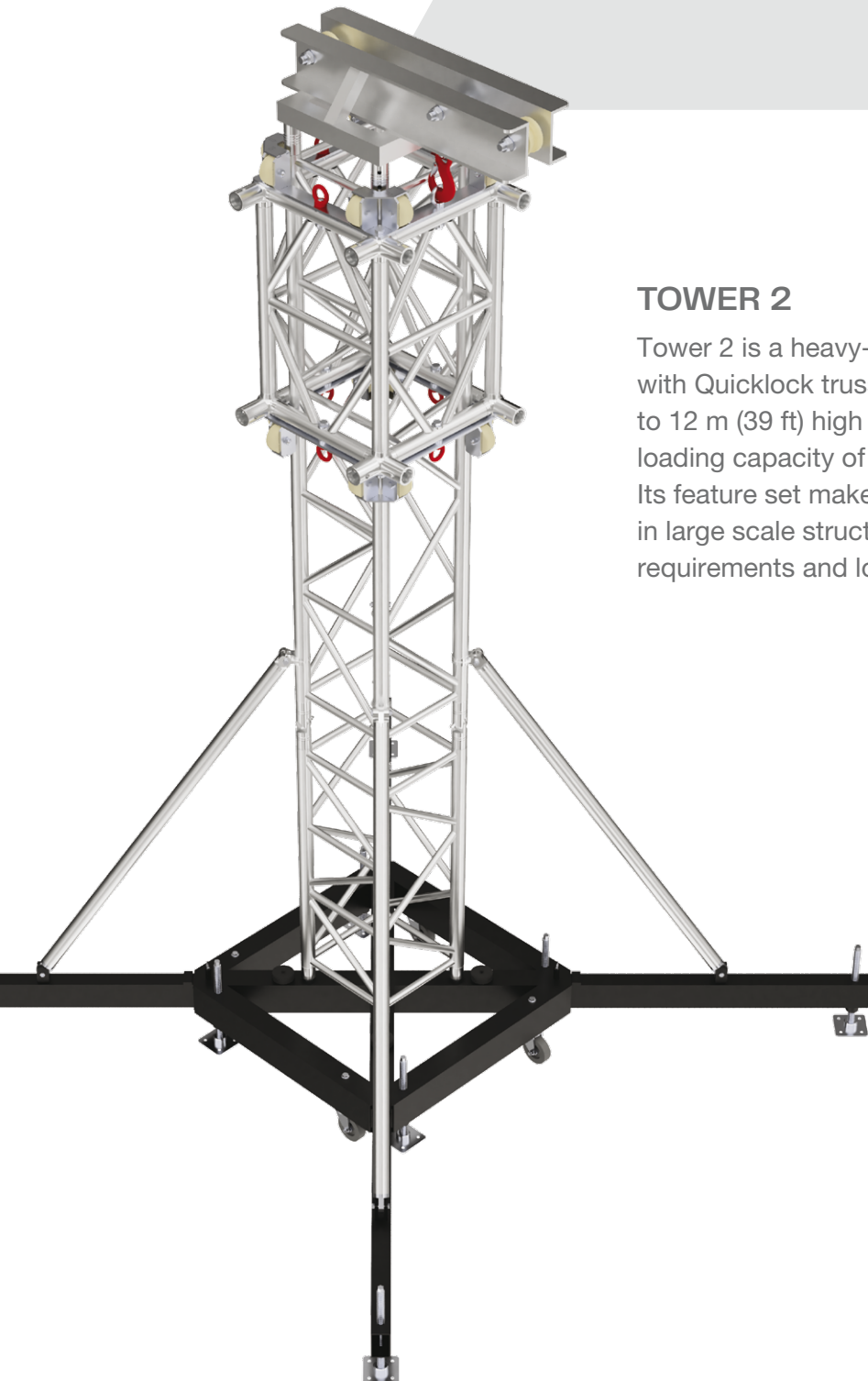

TOWER 2

Tower 2 is a heavy-duty tower constructed with Quicklock truss segments. It can go up to 12 m (39 ft) high and features a maximum loading capacity of 2000 kg (4,409 lbs). Its feature set makes it the right choice for use in large scale structures with higher loading requirements and longer spans.

PART LIST

T2T-BP	1 pc
T2T-SB	1 pc
T2T-TS-895	1 pc
T2T-LO	4 pcs
T1T-HS	4 pcs
T2T-SH	1 pc
TT44-100LD	1 pc
TT44-200LD	1 pc
TT44-300LD	3 pcs

SPECIFICATIONS

SELF WEIGHT	380 kg (838 lbs)
HEIGHT	12 m (39 ft)
LOAD CAPACITY	2000 kg (4,409 lbs)

TT44 MAST SECTION

MAIN TUBES	50 x 4 mm (1.97 x 0.16 in)
BRACES	25 x 3 mm (0.98 x 0.12 in)
ALLOY	EN AW-6082 T6



T2T-BP

Steel base plate
 980 x 980 x 340 mm
 (38.58 x 38.58 x 13.39 in)
 60.57 kg (133.53 lbs)



T2T-TS-895

Top section
 895 x 270 x 410 mm
 (35.24 x 10.63 x 16.14 in)
 22.33 kg (49.23 lbs)



T2T-LO

Long outrigger
 2045 x 110 x 340 mm
 (80.51 x 4.33 x 13.39 in)
 18.93 kg (41.73 lbs)

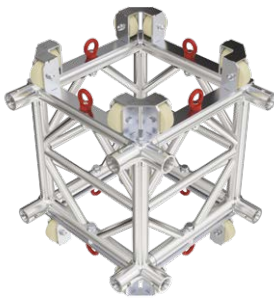

T2T-SBT54M

TT44 Sleeve block, TT54M
 637 x 752 x 637 mm
 (25.08 x 26.61 x 25.08 in)
 63.59 kg (140.19 lbs)

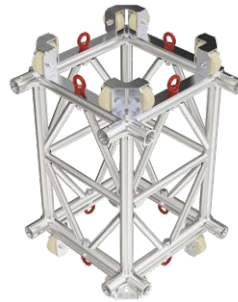

T2T-SBT74M

TT44 Sleeve block, TT74M
 637 x 992 x 637 mm
 (25.08 x 39.06 x 25.08 in)
 66.40 kg (146.38 lbs)

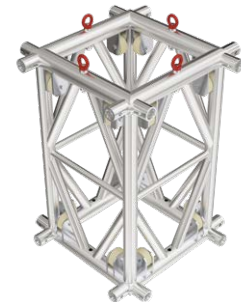

T2T-SBT104M

TT44 Sleeve block, TT104M
 740 x 1098 x 740 mm
 (29.13 x 43.23 x 29.13 in)
 52.1 kg (114.86 lbs)

OPTIONAL ACCESSORIES



T2T-SH

Safety hooks
 355 x 90 x 55 mm
 (13.98 x 3.54 x 2.17 in)
 1.53 kg (3.37 lbs)



T1T-HS

Hinge section
 49 x 166 x 66 mm
 (1.93 x 6.54 x 2.60 in)
 0.61 kg (1.33 lbs)

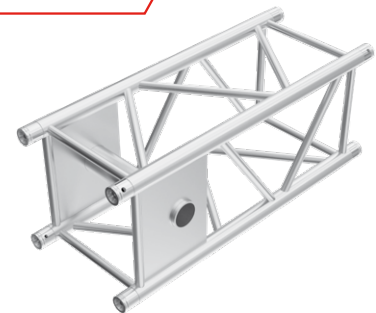



TT44-100+SF

Safety lock truss
 400 x 400 x 1000 mm
 (15.75 x 15.75 x 39.37 in)
 16.08 kg (35.45 lbs)

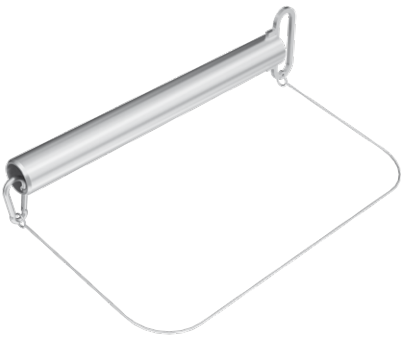
TOWER 2



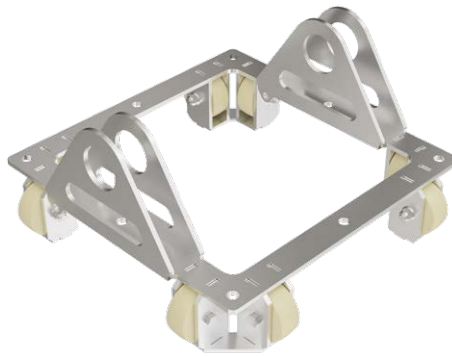

T2T-ST

 Safety steel tube
 655 x 150 x 62 mm (25.79 x 5.91 x 2.44 in)
 1.78 kg (3.92 lbs)



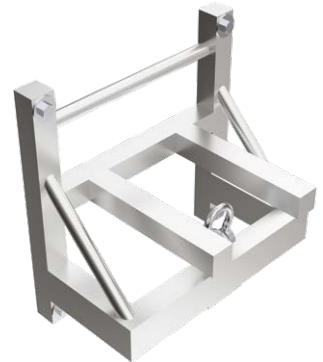

T2T-SBWFSF

 Steel wheel frame + safety tube frame
 584 x 584 x 285 mm (22.99 x 22.99 x 11.22 in)
 8.16 kg (17.99 lbs)



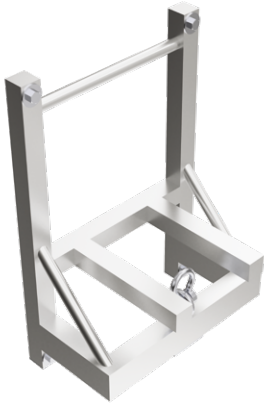

T2T-MH-SB54

 Motor holder on sleeve block 54M
 520 x 526 x 375 mm (20.47 x 20.71 x 14.76 in)
 8.16 kg (17.99 lbs)



T2T-MH-SB74

 Motor holder on sleeve block 74M
 520 x 766 x 375 mm (20.47 x 30.16 x 14.76 in)
 9.10 kg (20.07 lbs)

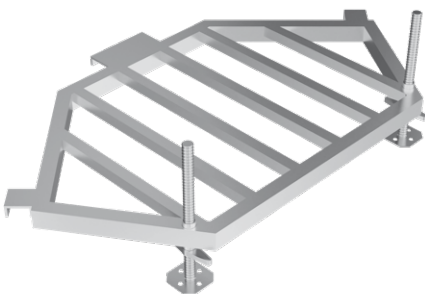

T2T-BF

 Ballast frame
 1100 x 1949 x 120 mm (43.31 x 76.73 x 4.72 in)
 34.90 kg (76.93 lbs)





BOLTED TOWER TFTB-L

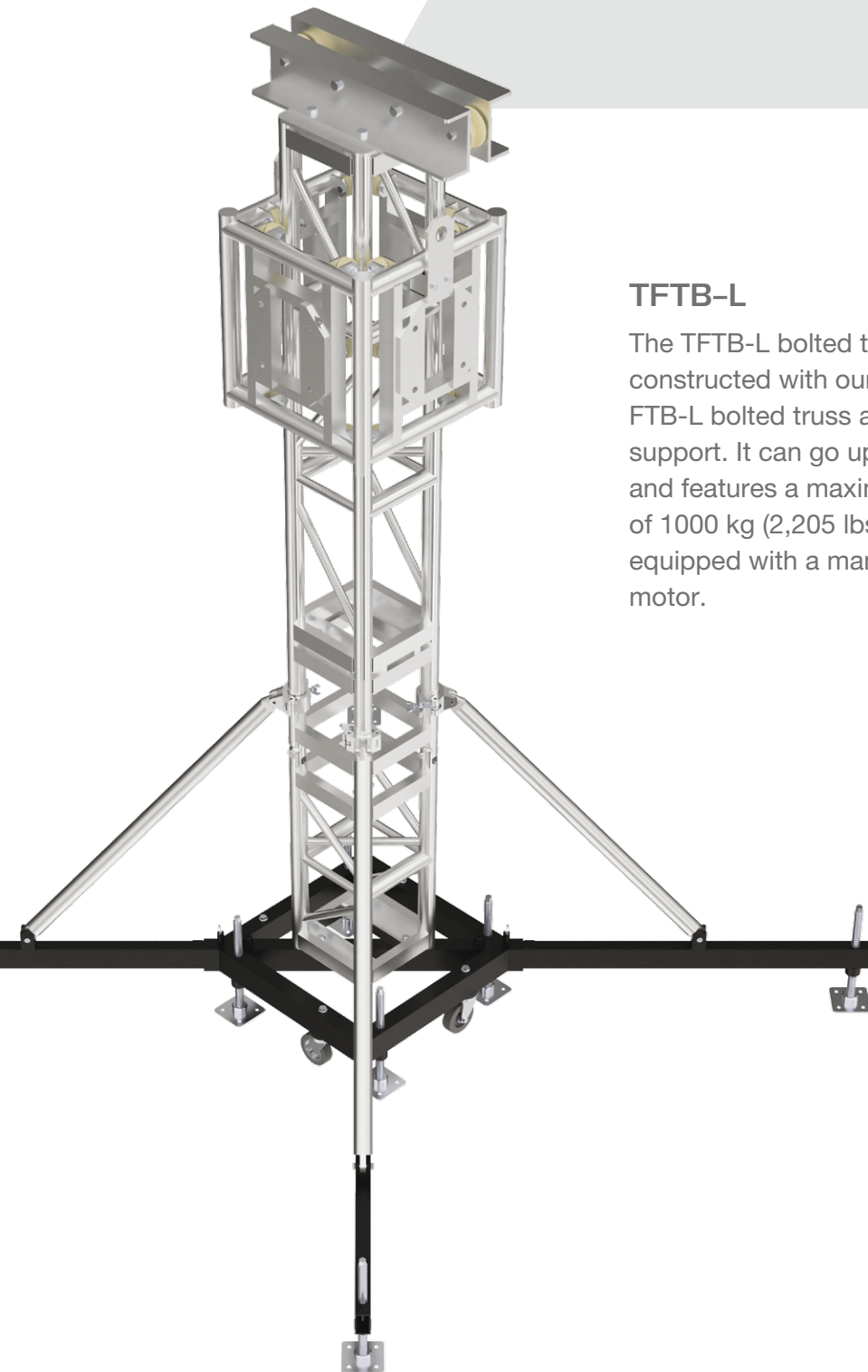

TFTB-L

The TFTB-L bolted truss tower system is constructed with our standard 12 in (304.8 mm) FTB-L bolted truss and is designed for ground support. It can go up to 7.5 m (24.6 ft) in height and features a maximum loading capacity of 1000 kg (2,205 lbs). The tower can be equipped with a manual chain hoist or rigging motor.

PART LIST

TFTB-L-BP	1 pc
TFTB-LHS	1 pc
TFTB-L-SB L	1 pc
TFTB-L-TS	1 pc
TFTB-L-LO	4 pcs
FTB-L-SB L ZO	2 pcs
FTB-L-5	1 pc
FTB-L-8	2 pcs

SPECIFICATIONS

SELF WEIGHT	145 kg (320 lbs)
HEIGHT	7.5 m (24.6 ft)
LOAD CAPACITY	1000 kg (2,205 lbs)

FTB-L MAST SECTION

MAIN TUBE	50 x 3 mm (1.97 x 0.12 in)
BRACES	25 x 3 mm (0.98 x 0.12 in)
ALLOY	EN AW-6082 T6



TFTB-L-BP

Steel base plate for TFTB-L
680 x 680 x 340 mm
(26.77 x 26.77 x 13.39 in)
11.30 kg (24.92 lbs)

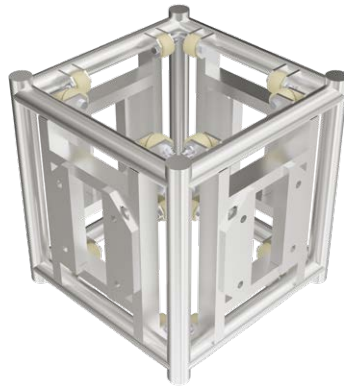

TFTB-L-SB L

Bolted tower sleeve block for FTB-L connection
539 x 549 x 539 mm
(21.22 x 21.61 x 21.22 in)
22.60 kg (49.82 lbs)



TFTB-L-TS

Top section for bolted tower
670 x 170 x 304 mm
(26.38 x 6.69 x 11.97 in)
7.94 kg (17.51 lbs)



TFTB-L-LO

Bolted tower long outrigger stabilizer
1575 x 110 x 340 mm
(62 x 4.33 x 13.39 in)
10.80 kg (23.80 lbs)



TFTB-L-HS

Hinge section for bolted tower
1.07 m (3.5 ft)
304 x 1067 x 304 mm
(11.97 x 42.00 x 11.97 in)
10.42 kg (22.96 lbs)



TFTB-L-SB L ZO

Removable rigging eye for the bolted tower sleeve block
90 x 220 x 97.5 mm
(3.54 x 8.66 x 3.82 in)
0.99 kg (2.19 lbs)

PA TOWER 05



PA TOWER 05

PA Tower 05 is a smaller tower with a unique design and impressive functionality. It can reach heights of up to 6 m (20 ft) and allows for a maximum load of 350 kg (772 lbs). It is equipped with a pulley, motor mount, and long outriggers.

SIZE

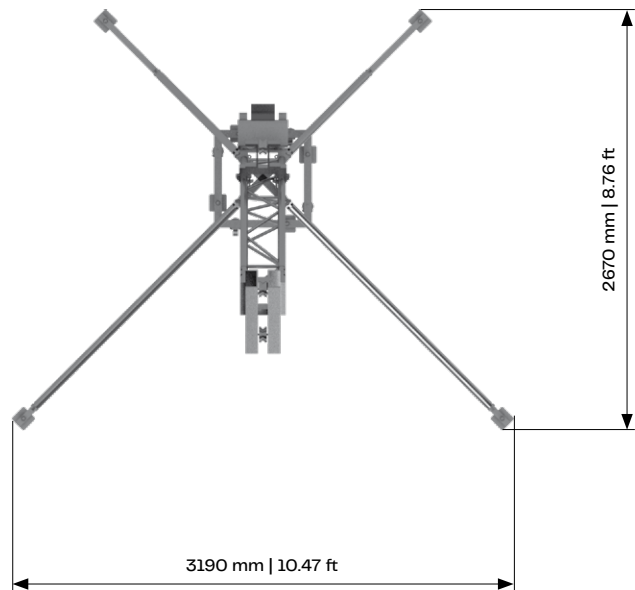
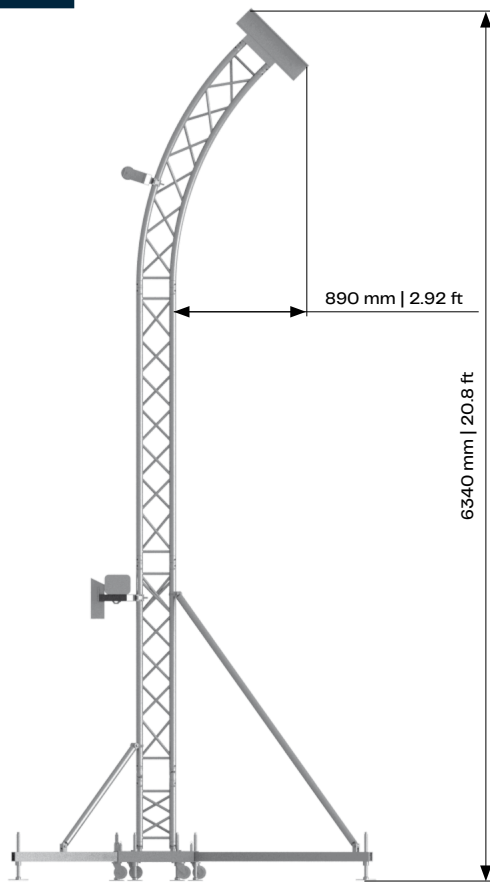

PART LIST

T1T-BP	1 pc
T1T-LO	2 pcs
T1T-TS-650+EB	1 pc
T1T-HS	4 pcs
FT34-50	1 pc
FT34-150	1 pc
FT34-200	1 pc
FT34-C-5	1/8 pc
T1T-LO-PA05	2 pcs
T1T-PU	1 pc
PA05 HW SET	1 pc

SPECIFICATIONS

MAX. LIFTING HEIGHT	6 m (20 ft)
MAX. LOADING CAPACITY	350 kg (772 lbs)
MAIN TUBES	50 x 2 mm (1.97 x 0.08 in)
BRACES	20 x 2 mm (0.79 x 0.08 in)
ALLOY	EN AW-6082 T6

PA TOWER 1

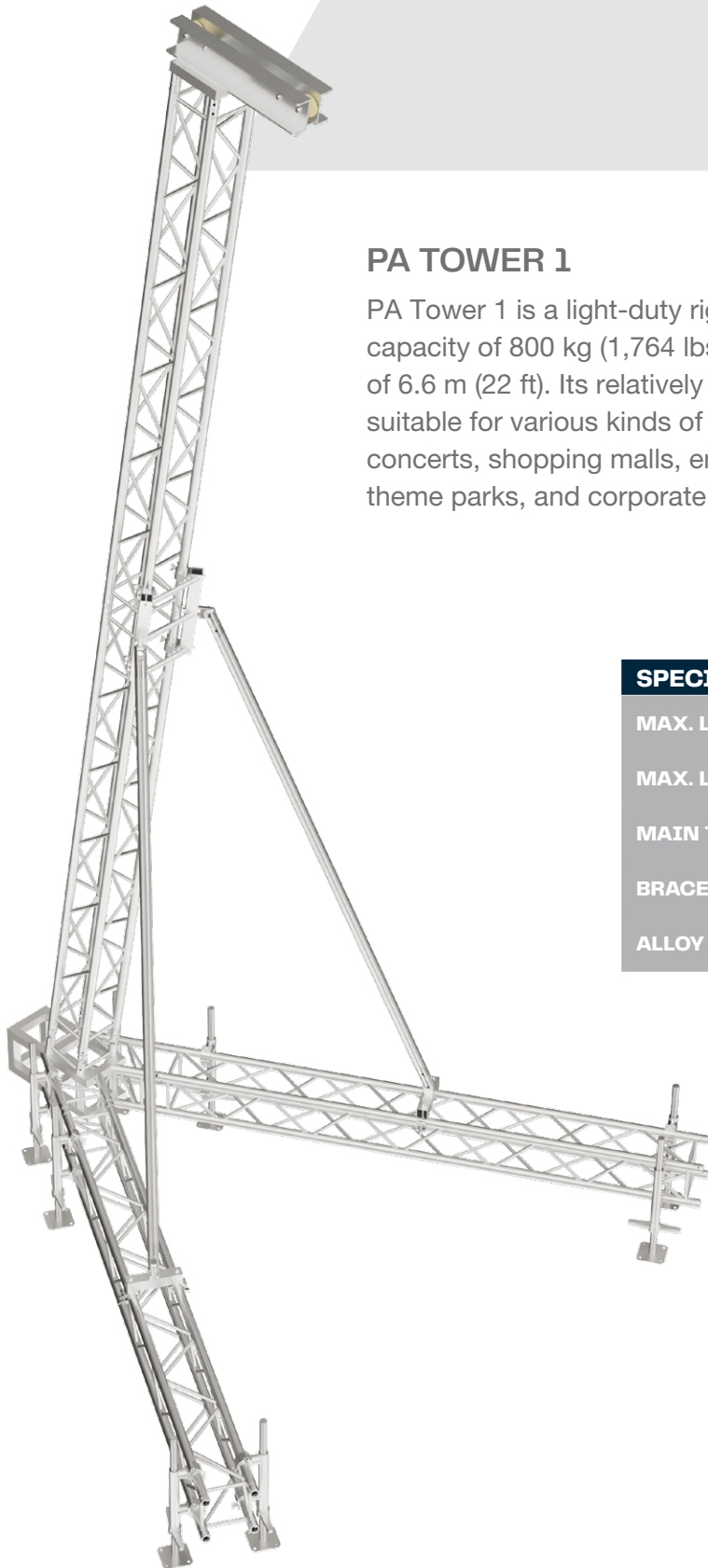

PA TOWER 1

PA Tower 1 is a light-duty rigging tower with a maximum loading capacity of 800 kg (1,764 lbs) and a maximum lifting height of 6.6 m (22 ft). Its relatively small dimensions make PA Tower 1 suitable for various kinds of applications, such as outdoor events, concerts, shopping malls, entrance halls, exhibitions, displays, theme parks, and corporate events.

SPECIFICATIONS

MAX. LIFTING HEIGHT	6.6 m (22 ft)
MAX. LOADING CAPACITY	800 kg (1,764 lbs)
MAIN TUBE	50 x 4 mm (1.97 x 0.16 in)
BRACES	20 x 2 mm (0.79 x 0.08 in)
ALLOY	EN AW-6082 T6

PART LIST

PA1-TOP	1 pc
PA1-BC60°	1 pc
PA1-RS	1 pc
PA1-CS	2 pcs
PA1-SP	2 pcs
PA1-SJ	8 pcs
PA1-SJA	8 pcs
TT34-300	4 pcs

SIZE

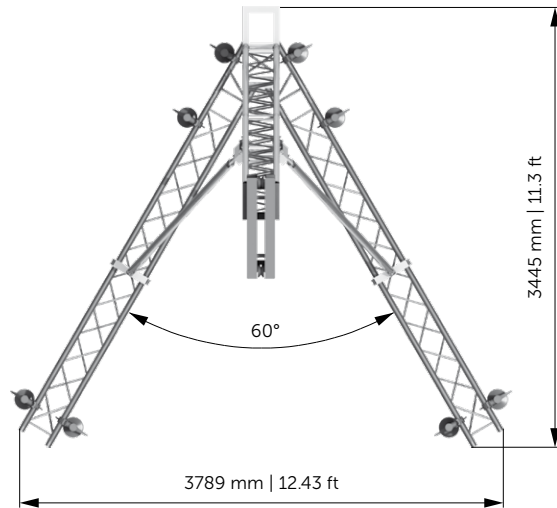
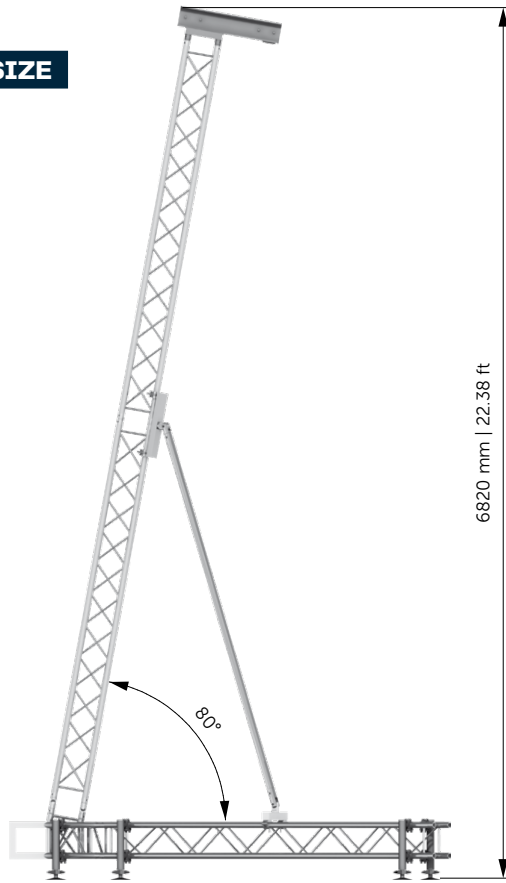

WIND MANAGEMENT

Max. wind velocity: 20m/s (44.74 mph)*
 * Valid for outdoor, temporary installations without snow or ice
 * Valid for places in III. terrain category = areas continuously covered with vegetation or buildings

BALLAST

AUDIO WEIGHT	AUDIO SURFACE	WIND SPEED	BALLAST
100 kg (220 lbs)	3 m ² (32.29 ft ²)	20 m/s (44.74 mph)	2 x 505 kg (1,113 lbs)
800 kg (1,764 lbs)	3 m ² (32.29 ft ²)	20 m/s (44.74 mph)	2 x 295 kg (650 lbs)

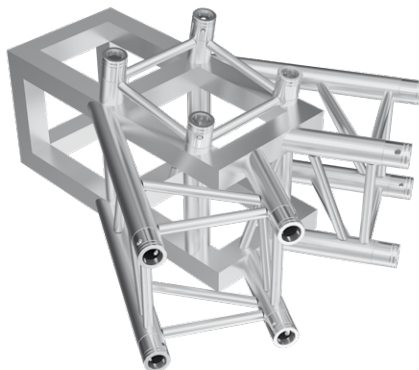

PA1-TOP

Top section
 800 x 260 x 290 mm
 (31.50 x 10.24 x 11.42 in)
 18.02 kg (39.71 lbs)

PA1-BC60°

Base 60° corner
 847 x 790 x 402 mm
 (33.35 x 31.10 x 15.83 in)
 19.52 kg (43.03 lbs)

PA VERTICAL TOWER 1

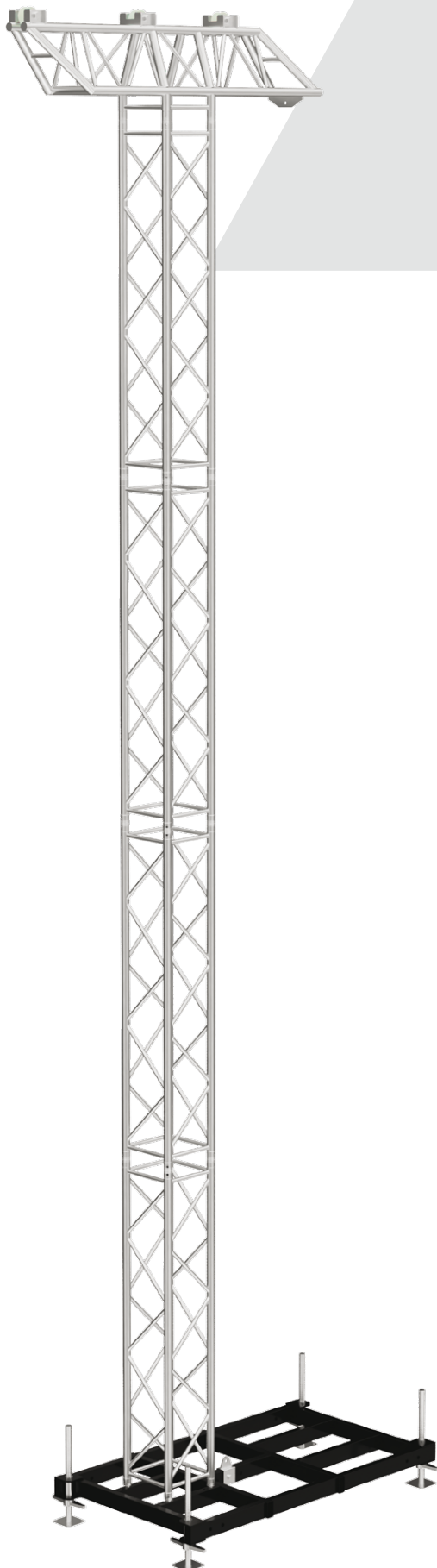

PA VERTICAL TOWER 1

Introducing our new PA Vertical Tower 1 (PAV1). Its specially designed top section and use of heavy-duty HT44 or TT44 truss segments, with Quicklock connection system, support up to 1000 kg (2,205 lbs) loads at up to 8 m (26 ft) to ensure safe and secure hanging of speaker arrays at your large-scale events. Due to its versatile design, the PAV1 not only serves as an independent PA tower or part of your stage setup, but also as stable support for LED walls.

PART LIST

PAV1-BP	1 pc
HT44-200	3 pcs
HT44-150	1 pc
HT44-50	1 pc
T1T-HS	1 pc
PAV1-TS	1 pc

SPECIFICATIONS

MAX. HEIGHT	8 m (26 ft)
MAX. LOAD	1000 kg (2,205 lbs)
BALLAST	2000 kg (4,410 lbs)

HT44 MAST SECTION

MAIN TUBE	50 x 3 mm (1.97 x 0.12 in)
BRACES	25 x 3 mm (0.98 x 0.12 in)
ALLOY	EN AW-6082 T6

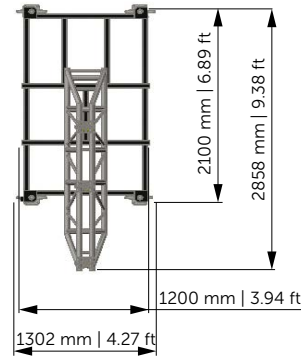
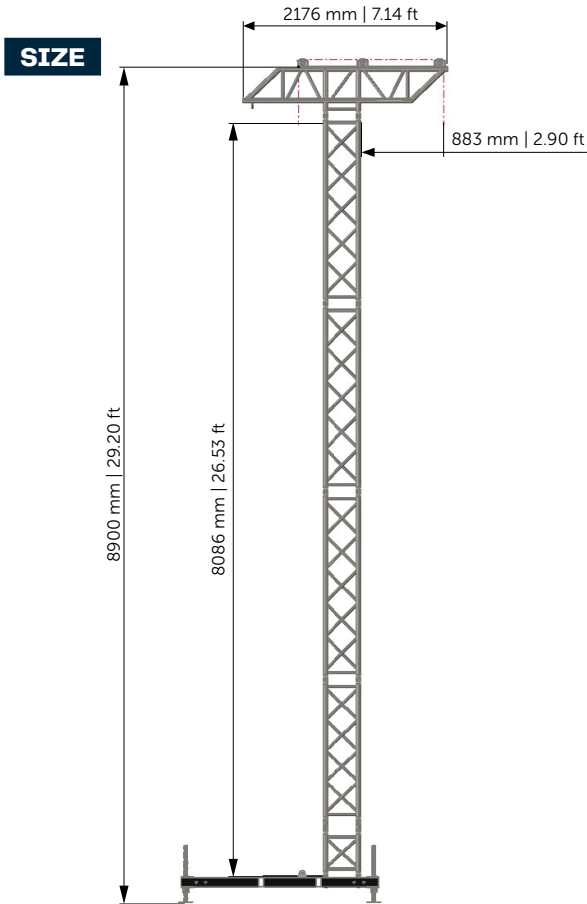

WIND MANAGEMENT

Max. wind velocity: 20m/s (44.74 mph)*

- * Valid for outdoor, temporary installations without snow or ice
- * Valid for places in III. terrain category = areas continuously covered with vegetation or buildings

BALLAST

AUDIO WEIGHT	AUDIO SURFACE	WIND SPEED	BALLAST
600 kg (1,323 lbs)	3 m ² (32.29 ft ²)	20 m/s (44.74 mph)	2000 kg (4,409 lbs)
1000 kg (2,205 lbs)	4.1 m ² (44.13 ft ²)	20 m/s (44.74 mph)	2900 kg (6,393 lbs)

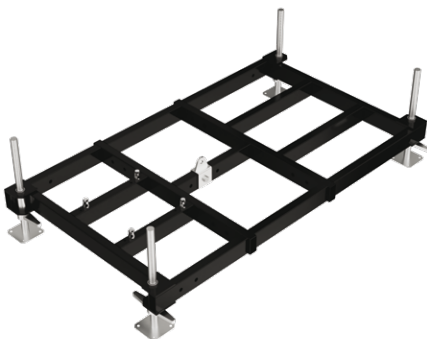

PAV1-BP

Base plate
 2150 x 1172 x 600 mm
 (84.65 x 46.14 x 23.62 in)
 103.64 kg (228.53 lbs)

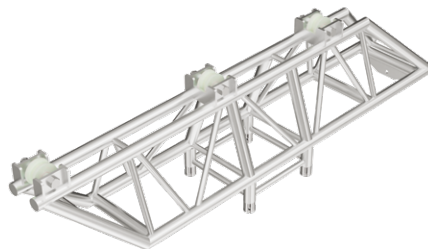

PAV1-TS

Top section
 2170 x 605 x 400 mm
 (85.43 x 23.82 x 15.75 in)
 34.65 kg (76.38 lbs)



T1T-HS

Hinge section
 49 x 166 x 66 mm (1.93 x 6.54 x 2.60 in)
 0.61 kg (1.33 lbs)

TOWER LIFTERS



Tower Lifters are reliable and easy-to-use solutions for lifting lighting, audio, and stage equipment. Designed for stability and quick setup, they are ideal for events, installations, and touring. The range includes both top-load and front-load models with various height and load capacities. Compact and durable, Tower Lifters ensure safe operation with built-in safety features and strong construction.



TLT-125

Black Top Load

Max. height: 3.8 m (12.47 ft)
Load capacity: 125 kg (275.58 lbs)
Weight: 21 kg (46.30 lbs)



TLT-150

Black Top Load

Max. height: 5.35 m (17.55 ft)
Load capacity: 150 kg (330.69 lbs)
Weight: 41 kg (90.39 lbs)



TLT-300

Black Top Load

Max. height: 6.5 m (21.33 ft)
Load capacity: 300 kg (661.39 lbs)
Weight: 129 kg (284.40 lbs)



TLF-220

Black Front Load

Max. height: 5.45 m (17.88 ft)
Load capacity: 220 kg (485.02 lbs)
Weight: 87 kg (191.80 lbs)



TLF-270

Black Front Load

Max. height: 6.65 m (21.82 ft)
Load capacity: 270 kg (595.25 lbs)
Weight: 144 kg (317.47 lbs)



TLT-SP-35

Spigot 35-29 mm



TLT-SP-50

Spigot 50-29 mm



TLF-ST5-1

Single Truss Support Adaptor (Outwards)



TLF-ST5-2

Single Truss Support - Clamp



TLT-US-35

U support for truss (25-45 cm truss)



TLT-US-50

U support for truss (25-45 cm truss)



TLF-LAS-1

Line array support



TLT-LB-35

Lighting bar / 6 positions



TLT-LB-50

Lighting bar / 6 positions



LED FRAMES

LED Support

An aluminium LED support frame with adjustable connection bar and ladder truss segments with a maximum height of 4 m (13.1 ft). Stable support for hanging LED screens.

LED Frame 1

LED Frame 1 (5 x 3 m) is a fast and easy system to assemble. It can support LED screens up to 5 x 3 m (16.4 x 9.8 ft) with a maximum weight of 1200 kg (2,645 lbs). The LED frame is constructed with FT44 and FT34 trussing segments.

LED Frame 2

LED Frame 2 (6 x 4m) is a fast and easy system to assemble. It can support LED screens up to 6 x 4 m (19.7 x 13.1 ft) with a maximum weight of 2000 kg (4,410 lbs). The LED frame is constructed from FT44 and TT54M trussing segments.

LED Frame 3

LED Frame 3 (8 x 6 m) is a fast and easy system to assemble. It can support LED screens up to 8 x 6 m (26.2 x 19.7 ft) with a maximum weight of 3000 kg (6,615 lbs). The LED frame is constructed from FT44 and TT74M trussing segments and has a max. lifting height of 8.6 m (28 ft).

LED Frame 4

LED Frame 4 (10 x 8 m) stands as the largest and most robust structure in the TAF LED frame lineup. It is engineered to securely support LED screens measuring up to 10 x 8 meters (32.81 x 26.25 ft) and weighing as much as 3500 kg (7,716.18 lbs).

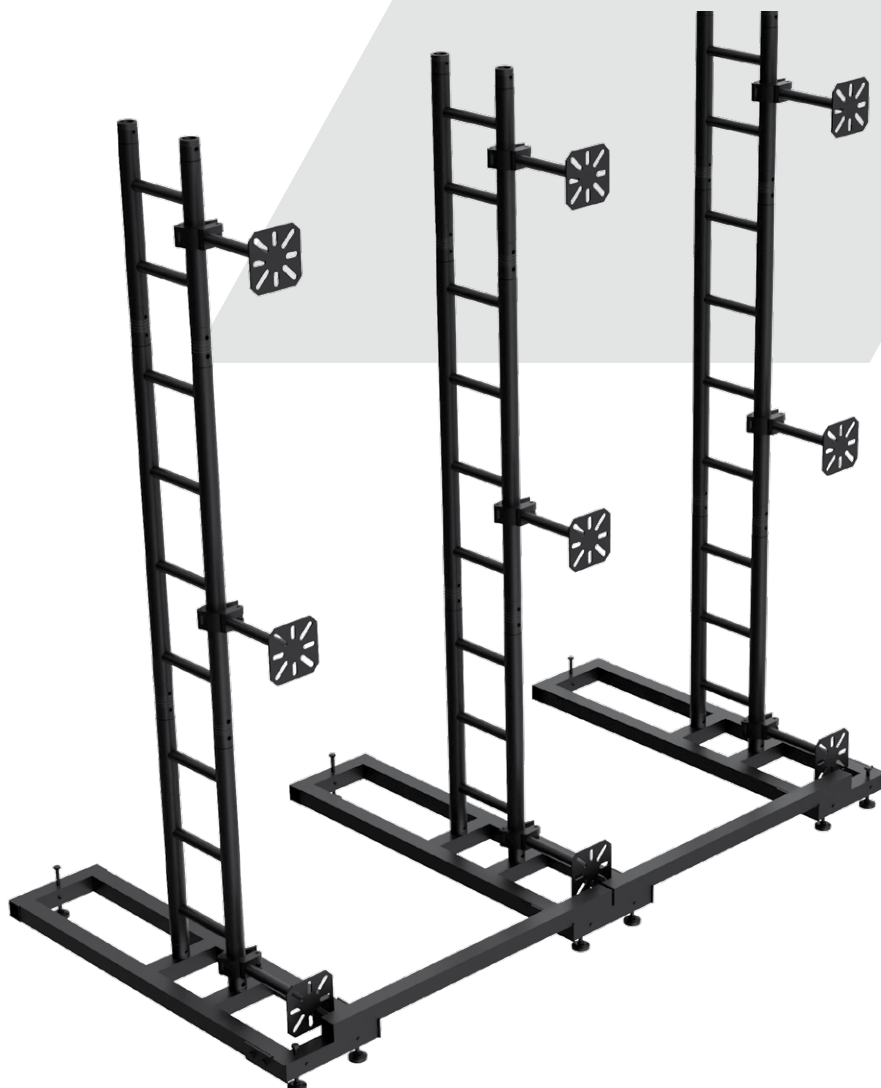

Safely suspend your LED screen with our highly flexible and stable support system. An aluminium base-unit, adjustable connection bar, and ladder style trussing segments provide extremely stable support for hanging your LED screens. The wall system is based on our HT32 trussing line, which provides high stability, as larger LED screens impose heavier loads on the system. The wall support is equipped with side-entry clamps and includes a universal connection plate for mounting different LED panel sizes. Designed for indoor use.

SPECIFICATIONS

Max. Height	4 m (13.1 ft)
BASE UNIT	50 x 50 x 3 mm (1.97 x 1.97 x 0.12 in) profile + levelling feet
SEGMENTS	Ladder truss - 290 mm (11.4 in), main tube 50 x 3 mm (1.97 x 0.12 in), braces 30 x 3 mm (1.18 x 0.12 in)
USAGE	Indoors



LED-SUPBASE

19.4 kg (42.77 lbs)



LED-CONBAR-ENDF

1.36 kg (3.00 lbs)



LED-CONPART

1 kg (2.21 lbs)



LED-CONBAR



LED-PIPE

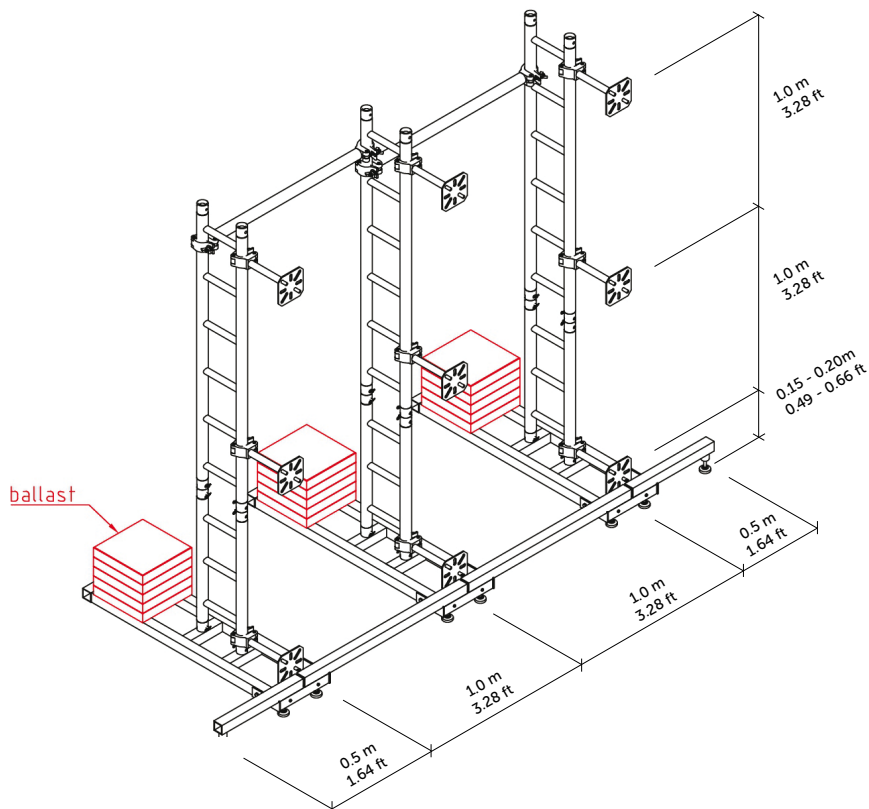

BALLAST

2 m (6.6 ft) height	17 kg/base plate (13.4 lbs/base plate)
4 m (13.1 ft) height	131 kg/base plate (100.8 lbs/base plate)

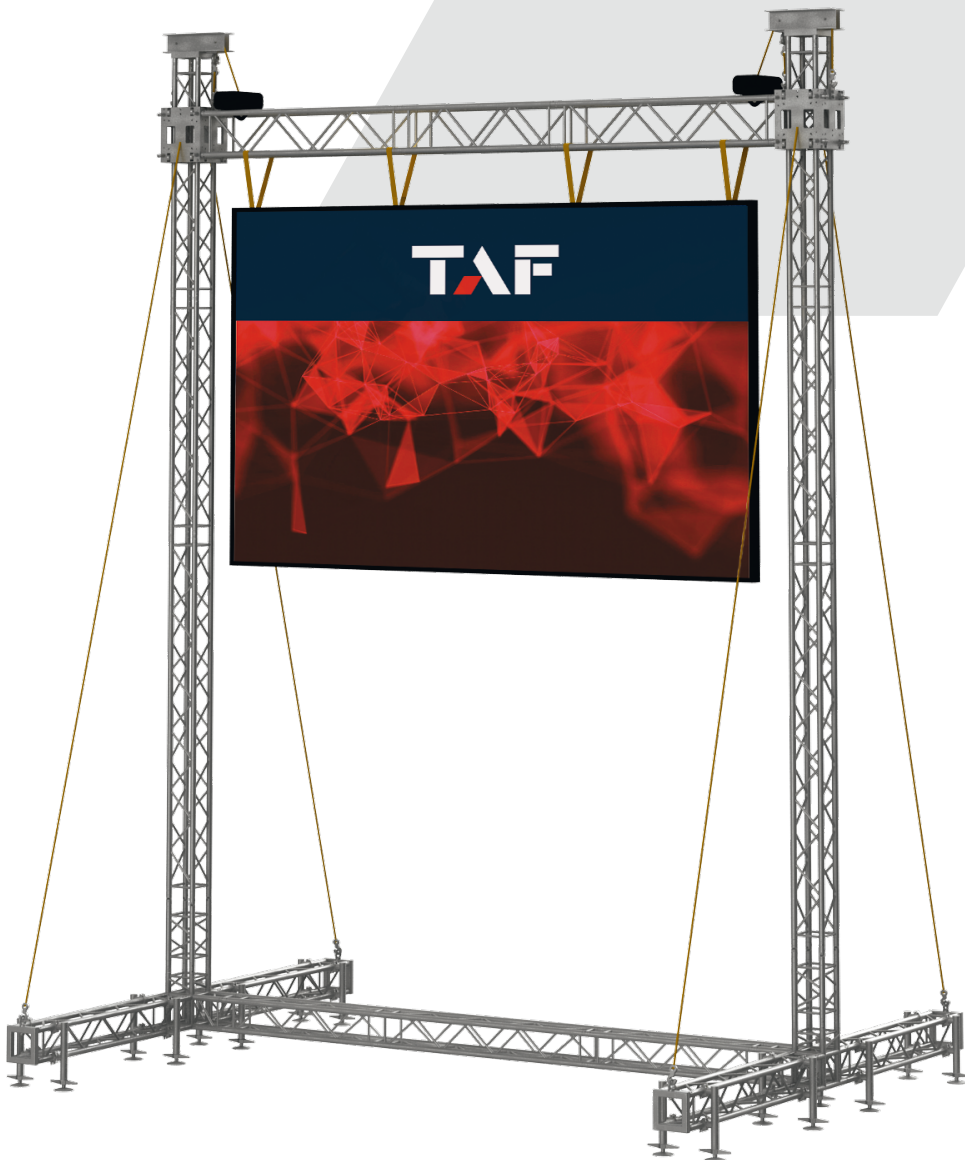

LED Frame 1 (5 x 3 m) is a fast and easy system to assemble. It can support LED screens up to 5 x 3 m (16.4 x 9.8 ft) with a maximum weight of 1200 kg (2,645 lbs). The LED frame is constructed from FT44 and FT34 trussing segments.

SPECIFICATIONS

Max. dimension	6.55 x 4.65 x 8.55 m (21.49 x 15.26 x 28.05 ft)
Max. LED size	5 x 3 m (16.4 x 9.8 ft)
Max. height	8.49 m (27.9 ft)
Max. load capacity	1200 kg (2,645 lbs)
Total weight of construction	650 kg (1,433 lbs)

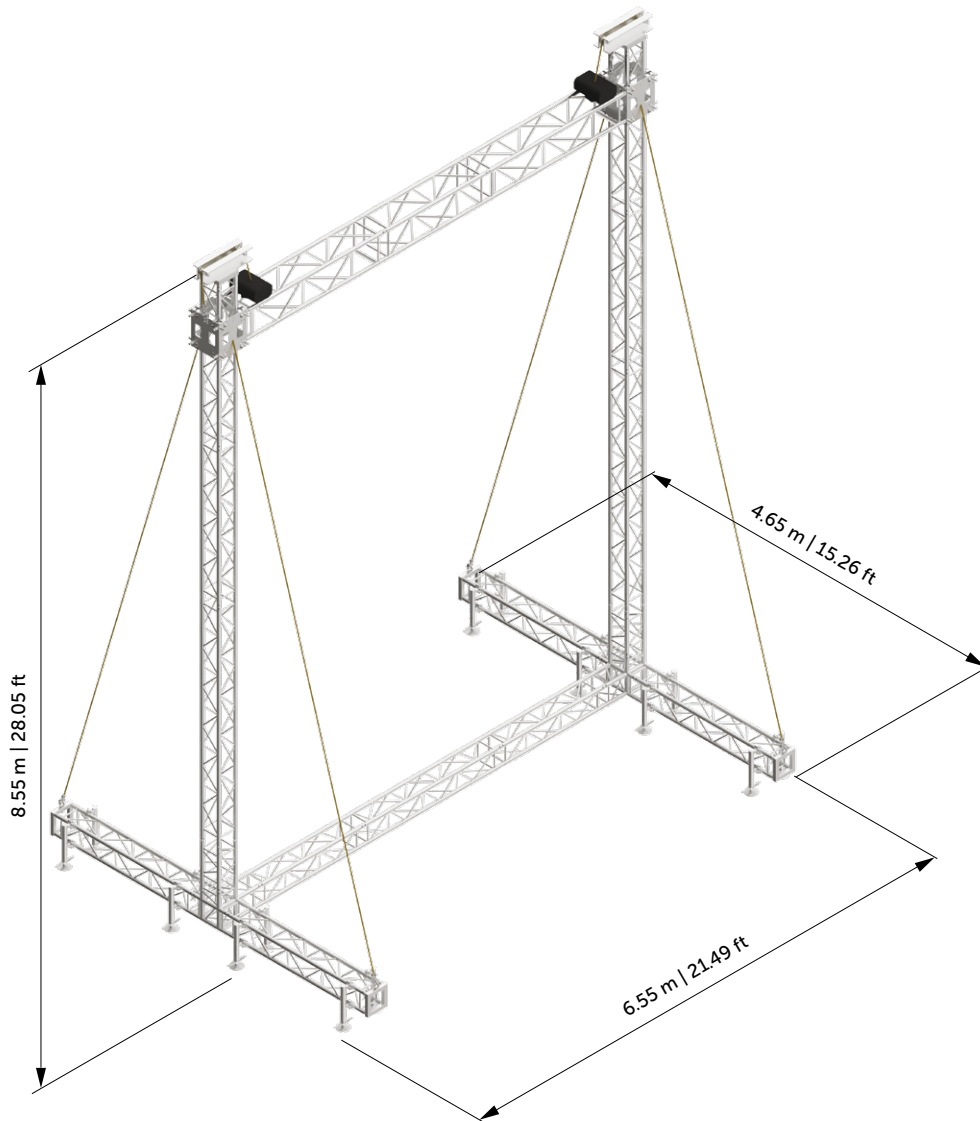

WIND MANAGEMENT

Max. wind velocity: 20 m/s (44.74 mph)*

- * Valid for outdoor, temporary installations without snow or ice
- * Valid for places in III. terrain category = areas continuously covered with vegetation or buildings

BALLAST

Min. ballast for each tower base	1100 kg (2,425 lbs)
Total ballast	4400 kg (9,700 lbs)

The ballast must be applied for secure usage of this LED frame.

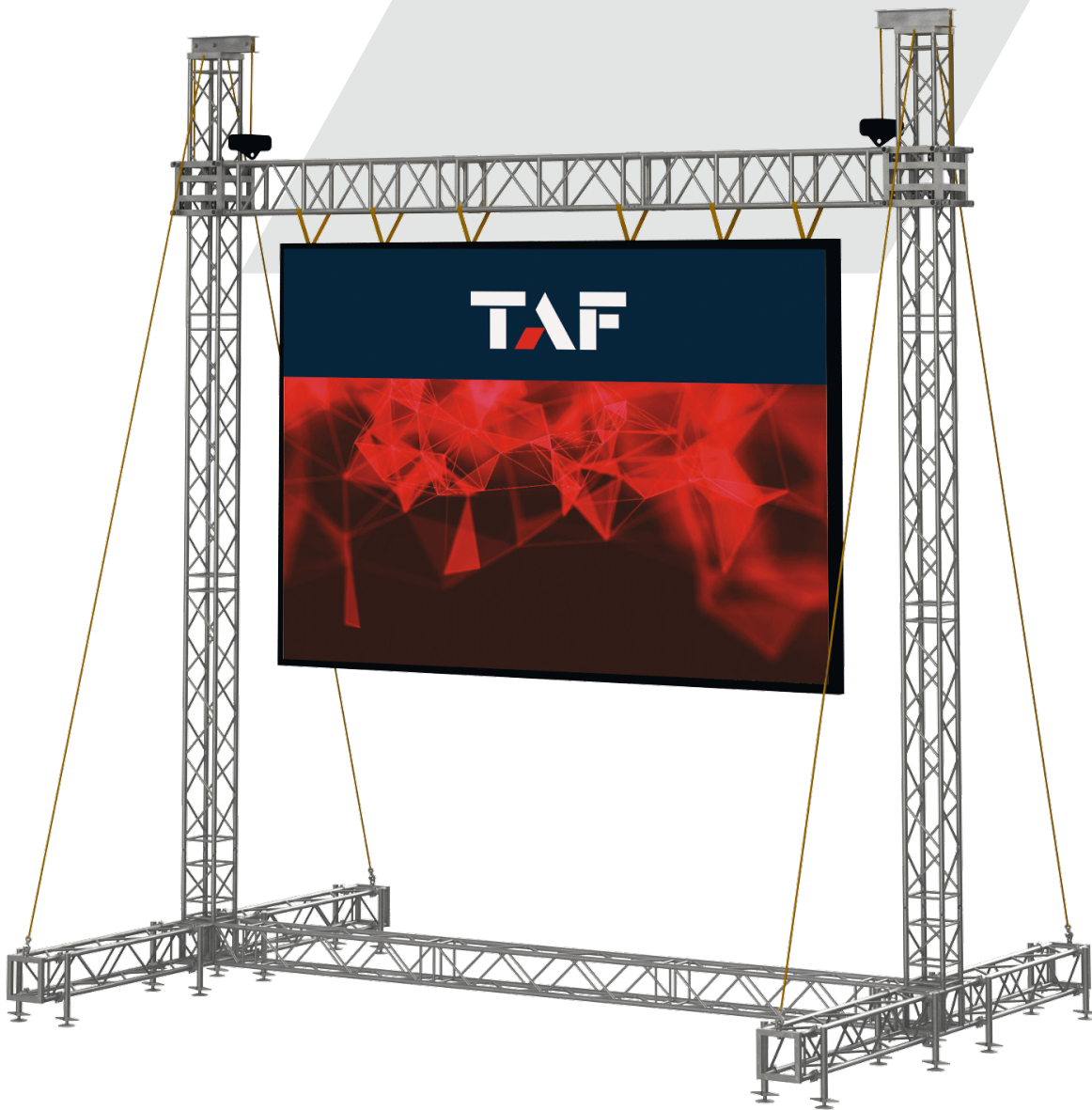

LED Frame 2 (6 x 4 m) is a fast and easy system to assemble that can support LED screens up to 6 x 4 m (19.7 x 13.1 ft) with a maximum weight of 2000 kg (4,410 lbs). The LED frame is constructed from FT44 and TT54M trussing segments.

SPECIFICATIONS

Max. dimension	8.40 x 5.70 x 9.05 m (27.56 x 18.70 x 29.69 ft)
Max. LED size	6 x 4 m (19.7 x 13.1 ft)
Max. height	9 m (29.5 ft)
Max. load capacity	2000 kg (4,410 lbs)
Total weight of construction	850 kg (1,874 lbs)

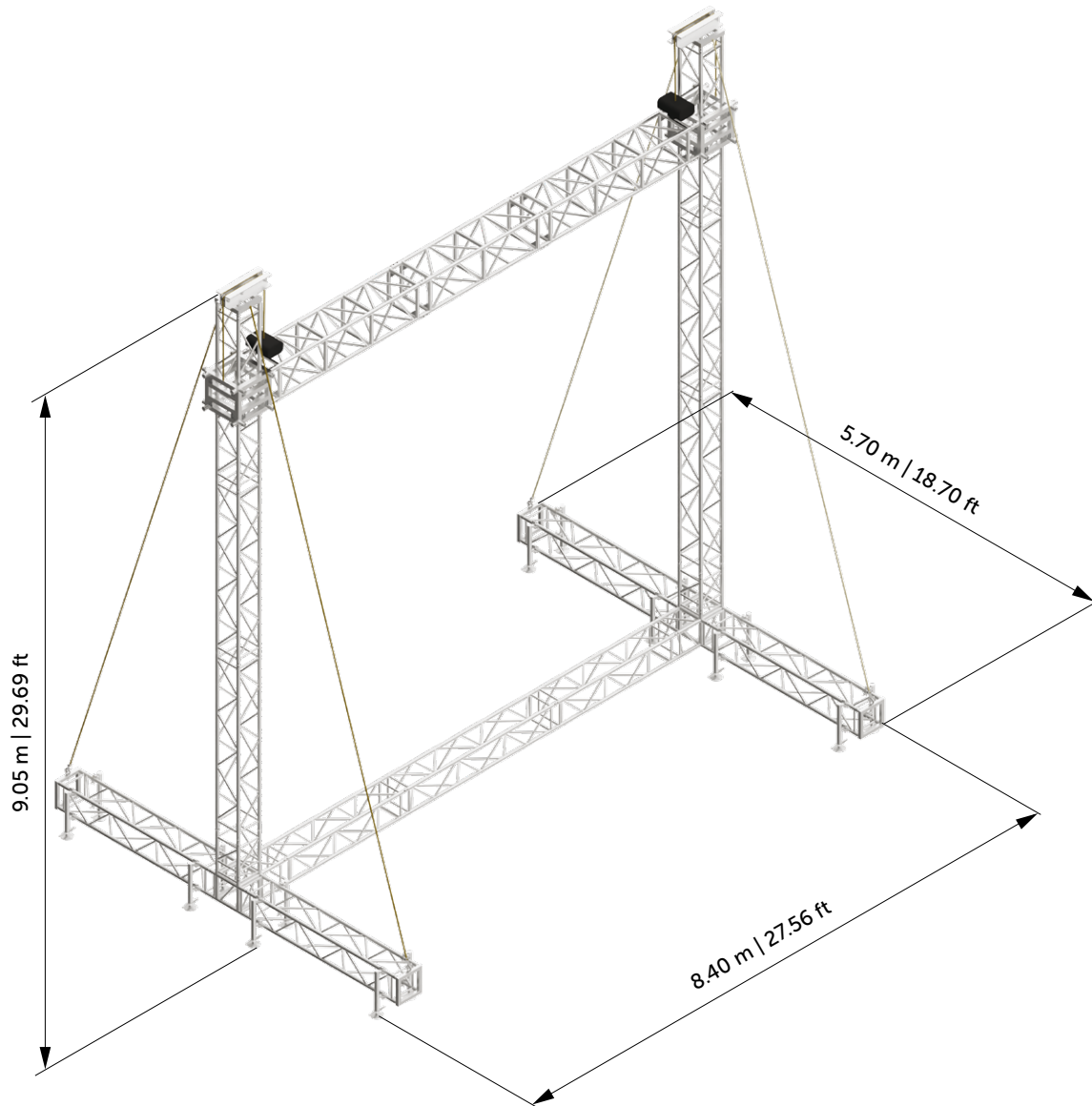

WIND MANAGEMENT

Max. wind velocity: 20 m/s (44.74 mph)*

- * Valid for outdoor, temporary installations without snow or ice
- * Valid for places in III. terrain category = areas continuously covered with vegetation or buildings

BALLAST

Min. ballast for each tower base	1000 kg (2,205 lbs)
Total ballast	4000 kg (8,818 lbs)

The ballast must be applied for secure usage of this LED frame.

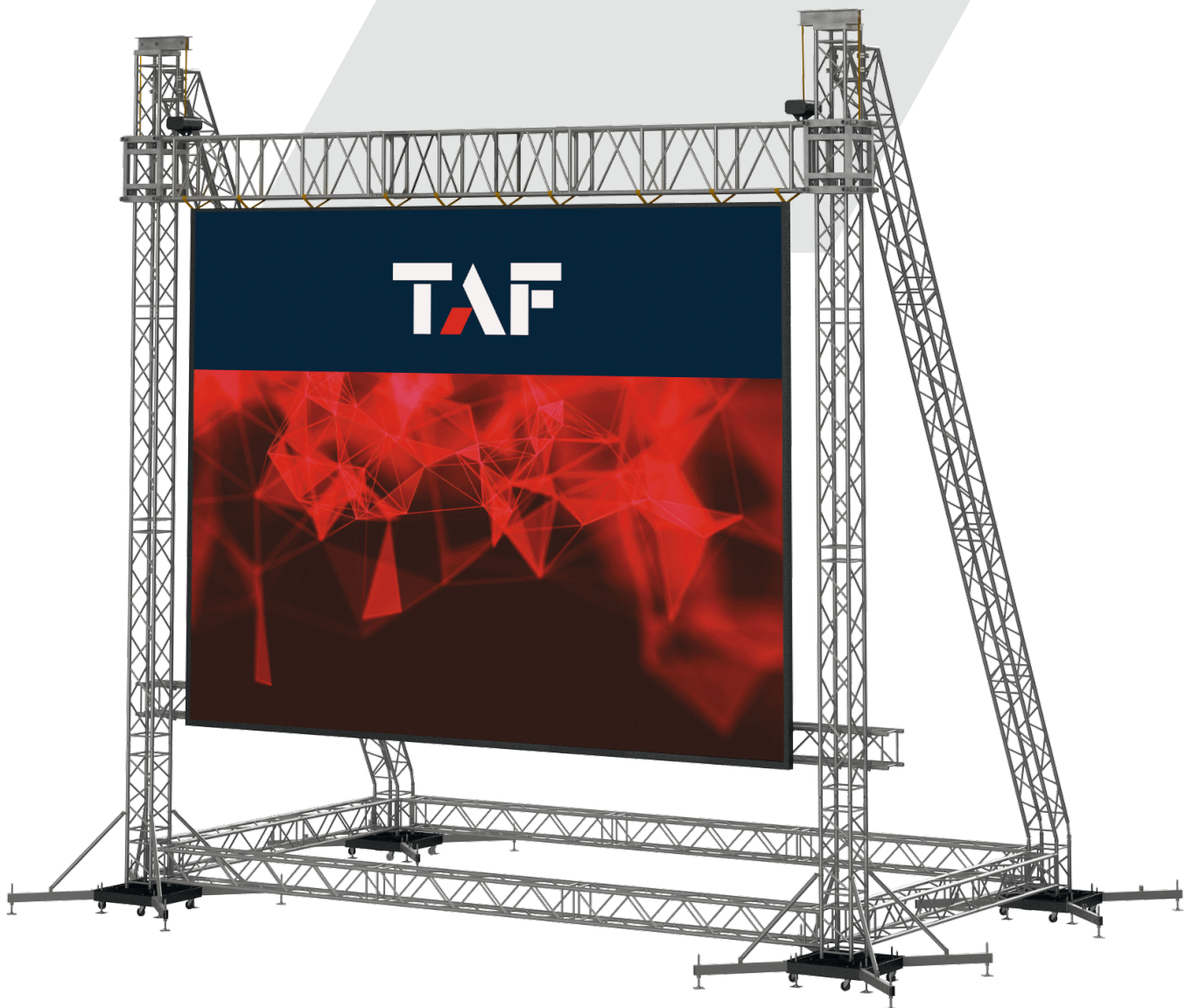

LED Frame 3 (8 x 6 m) is a fast and easy system to assemble. It can support LED screens up to 8 x 6 m (26.2 x 19.7 ft) with a maximum weight of 3000 kg (6,615 lbs). The LED frame is constructed from FT44 and TT74M trussing segments and has a max. lifting height of 8.6 m (28 ft).

SPECIFICATIONS

Max. dimension	11.57 x 7.48 x 10.20 m (37.96 x 24.54 x 33.46 ft)
Max. LED size	8 x 6 m (26.2 x 19.7 ft)
Max. height	10.2 m (33.5 ft)
Max. load capacity	3000 kg (6,615 lbs)
Total weight of construction	1200 kg (2,645 lbs)

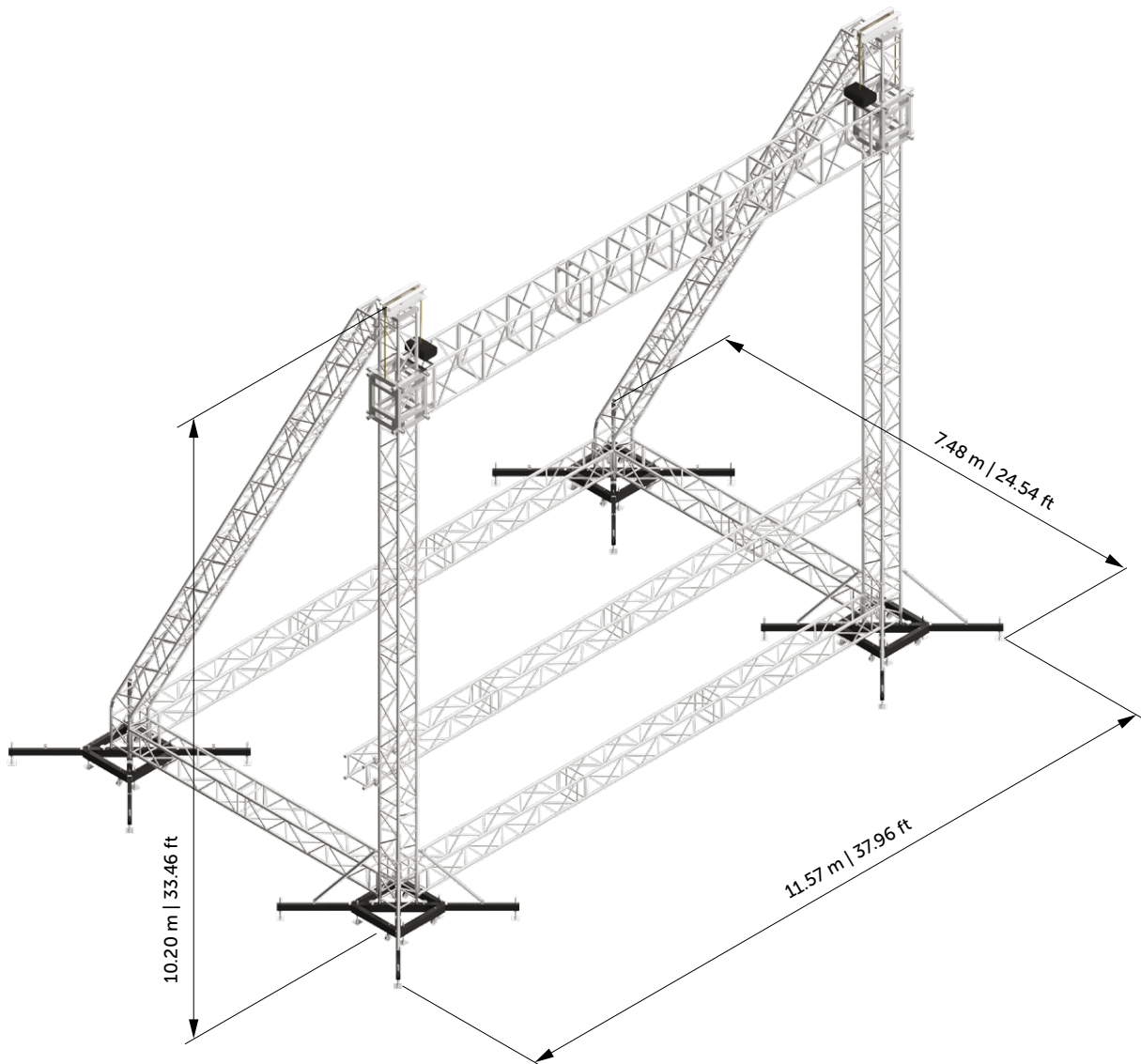

WIND MANAGEMENT

Max. wind velocity: 20 m/s (44.74 mph)*

- * Valid for outdoor, temporary installations without snow or ice
- * Valid for places in III. terrain category = areas continuously covered with vegetation or buildings

BALLAST

Min. ballast for each front tower base	450 kg (992 lbs)
Min. ballast for each rear tower base	1750 kg (3,858 lbs)
Total ballast	4400 kg (9,700 lbs)

The ballast must be applied for secure usage of this LED frame.



LED Frame 4 (10 x 8 m) is the largest and strongest structure in the TAF LED frame range. It is designed to safely support LED screens up to 10 x 8 meters (32.81 x 26.25 ft) in size and weighing up to 3500 kg (7,716.18 lbs).

SPECIFICATIONS

Max. dimension	14.12 x 8.13 x 12.21 m (46.33 x 26.67 x 40.06 ft)
Max. LED size	10 x 8 m (32.81 x 26.25 ft)
Max. height	12.21 m (40.06 ft)
Max. load capacity	3500 kg (7,716.18 lbs)
Total weight of construction	2270 kg (5,004.49 lbs)

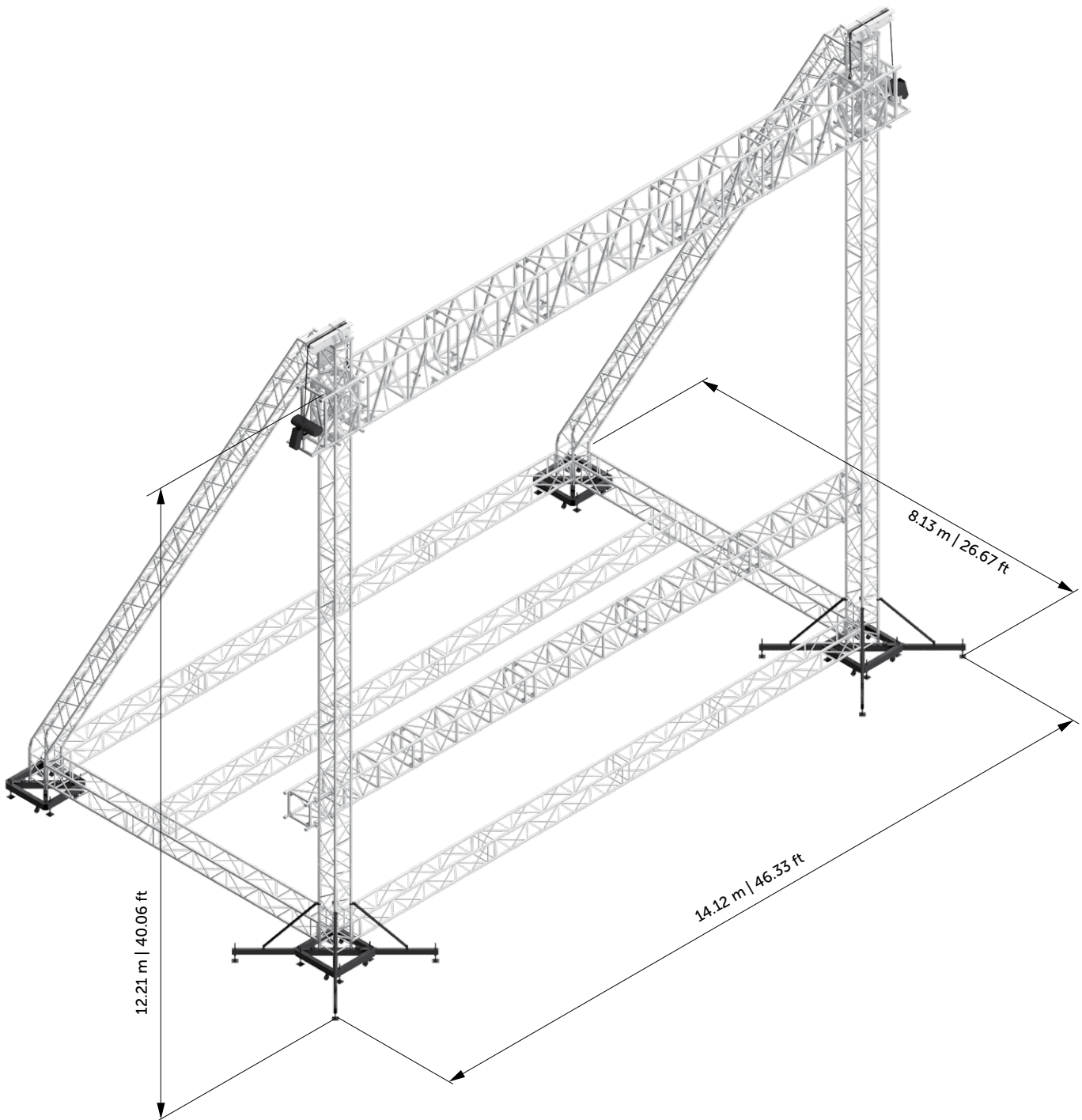

WIND MANAGEMENT

Max. wind velocity: 16 m/s (35.79 mph) *

- * Valid for outdoor, temporary installations without snow or ice
- * Valid for places in III. terrain category = areas continuously covered with vegetation or buildings

BALLAST

Max. LED screen weight	3500 kg (7,716.18 lbs)
Min. ballast – 1 out of 8	1800 kg (3,968.32 lbs)
Total ballast	14 400 kg (31,746.60 lbs)

8 ballasts must be placed according to a static calculation for secure usage of this LED frame.



ROOFS

TAF offers a wide range of roofing systems designed for events of basically any size. The wide variety of roof systems dimensions and designs ensure you will find the right roof for your specific requirements.



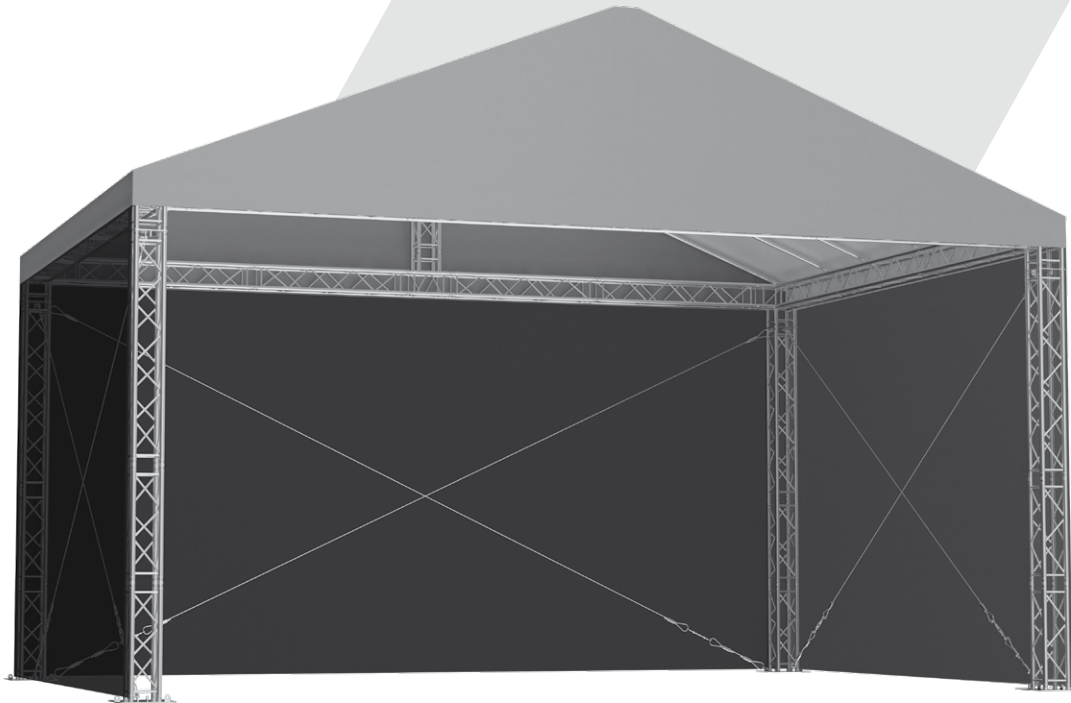

ROOF RST

TAF's standard roofs are available in three different dimensions and are normally used for small events. Their main advantages are fast and easy assembly, together with the fact that they are constructed from standard Quicklock FT34 trussing, which can also be utilized to build other structures.

USED CONSTRUCTION SYSTEMS

Mast section	FT34
Rafters	FT31

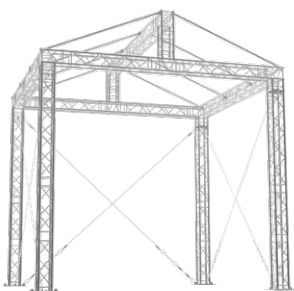

RST 4 x 4 m	
Max. load bearing capacity	3708 kg (8,175 lbs)
Total weight	530 kg (1,168 lbs)

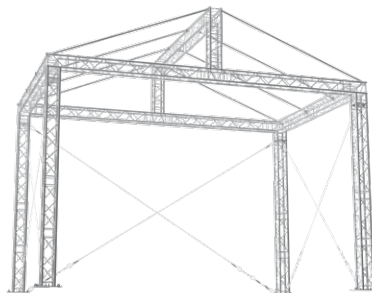

RST 6 x 4 m	
Max. load bearing capacity	2460 kg (5,423 lbs)
Total weight	580 kg (1,279 lbs)

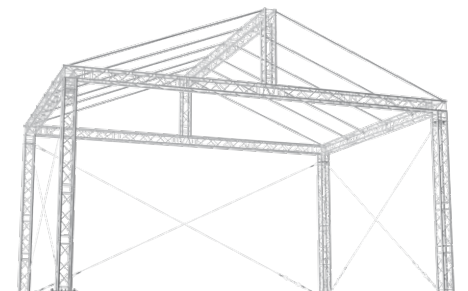

RST 8 x 6 m	
Max. load bearing capacity	1903 kg (4,195 lbs)
Total weight	720 kg (1,587 lbs)

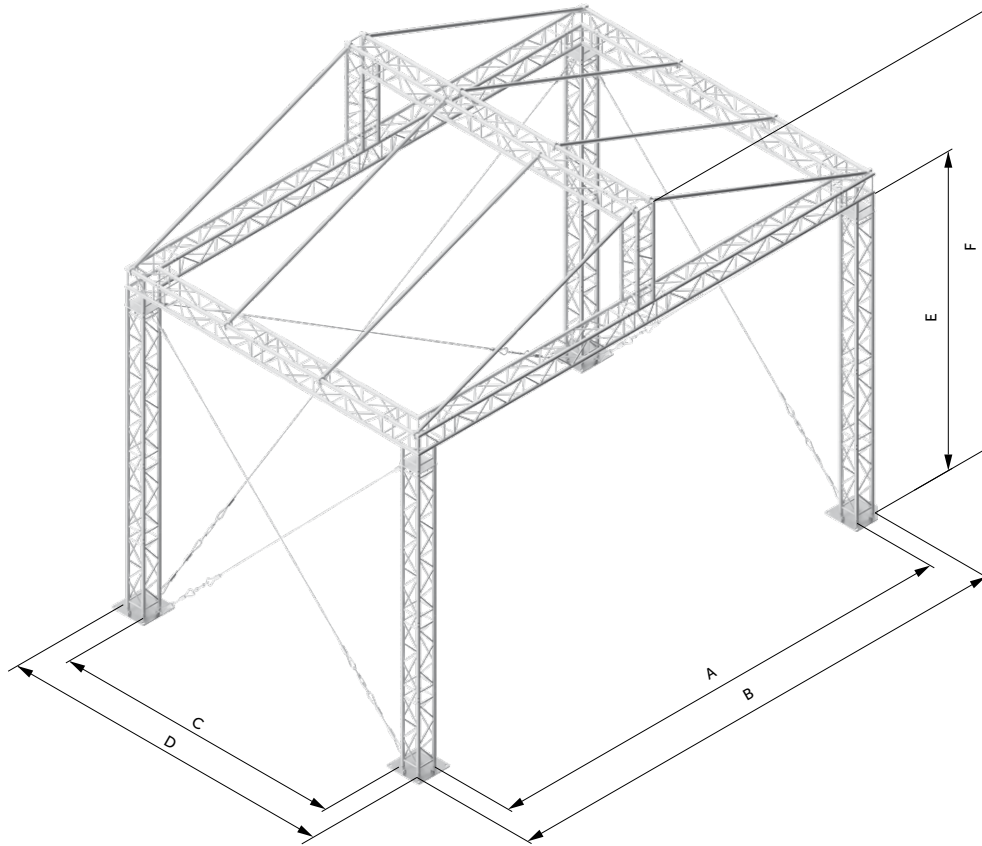

STAGE MEASUREMENTS

STAGE SIZE	Inside width	Overall width	Inside depth	Overall depth	Clearance	Height
	A	B	C	D	E	F
4 x 4 m (13.12 x 13.12 ft)	4.42 m (14.50 ft)	5 m (16.40 ft)	3.92 m (12.86 ft)	4.5 m (14.76 ft)	4.22 m (13.85 ft)	5.47 m (17.95 ft)
6 x 4 m (19.69 x 13.12 ft)	6.42 m (21.06 ft)	7 m (22.97 ft)	3.92 m (12.86 ft)	4.5 m (14.76 ft)	4.22 m (13.85 ft)	5.82 m (19.09 ft)
8 x 6 m (26.25 x 19.69 ft)	8.42 m (27.62 ft)	9 m (29.53 ft)	5.92 m (19.42 ft)	6.5 m (21.33 ft)	4.22 m (13.85 ft)	6.22 m (20.41 ft)

WIND MANAGEMENT

Wind resistance is calculated with 3 side mesh canopies applied to the structure (2 side canopies and one rear canopy). The three roof walls with canopies must be secured by guy wire cross bracing at all times with a min. loading capacity of 1000 kg (2,205 lbs).

In service max. windspeed - 15 m/s - 54 km/h - 33 mph

Out of service max. windspeed - 28 m/s - 101 km/h - 62 mph

BALLAST

ROOF RST 4 x 4 m	ROOF RST 6 x 4 m	ROOF RST 8 x 6 m
Option 1 400 kg / 882 lbs min. ballast for each tower base = total of 1600 kg / 3,527 lbs	Option 1 650 kg / 1,433 lbs min. ballast for each tower base = total of 2600 kg / 5,732 lbs	Option 1 800 kg / 1,764 lbs min. ballast for each tower base = total of 3200 kg / 7,055 lbs
Option 2 350 kg / 772 lbs ballasts in the 3.5 m (11.5 ft) range from each tower leg *	Option 2 600 kg / 1,323 lbs ballasts in the 3.5 m (11.5 ft) range from each tower leg *	Option 2 800 kg / 1,764 lbs ballasts in the 3.5 m (11.5 ft) range from each tower leg *

* attached to the structure by guy wires following the layout in static calculation.

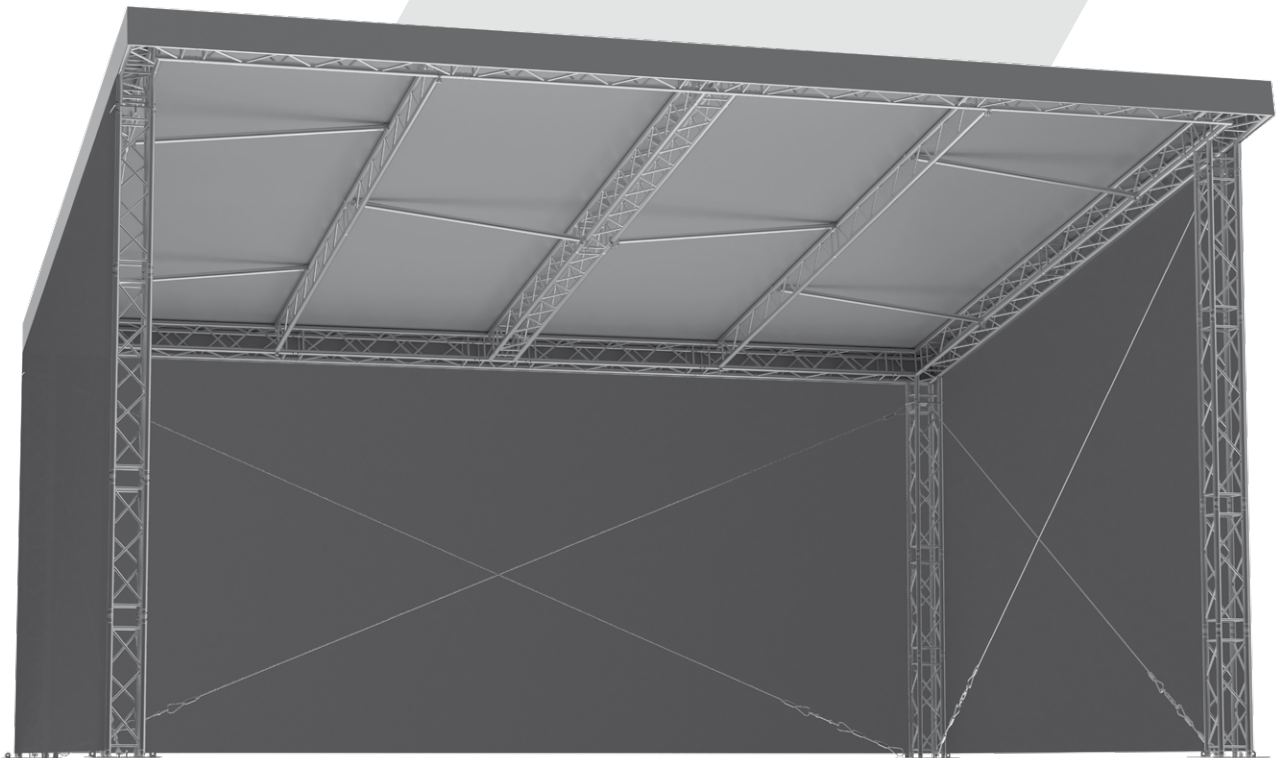

RSTS SLOPING ROOF

This roof system is unique in its design, as the top of the roof is not a gable, but slanted or pitched with a 10° angle, helping to manage the drainage of rainwater. It is mostly constructed from standard HT34 trussing segments. This roof can accommodate stage sizes up to 8 x 6 m (26.3 x 19.7 ft). Its clearance in the front is 5 m (16.4 ft) and in the back is 3.7 m (12.1 ft). The gable roof can be installed with a top cover (PVC only), along with standard side canopies.

USED CONSTRUCTION SYSTEMS

Mast section	HT34
Rafters	HT32, HT34

SPECIFICATIONS

Max. dimensions	9 x 7.5 m (29.53 x 24.61 ft)
Max. height	5.3 m (17.39 ft)
Max. load bearing capacity	3100 kg (6,834 lbs)
Total weight of construction	800 kg (1,764 lbs)

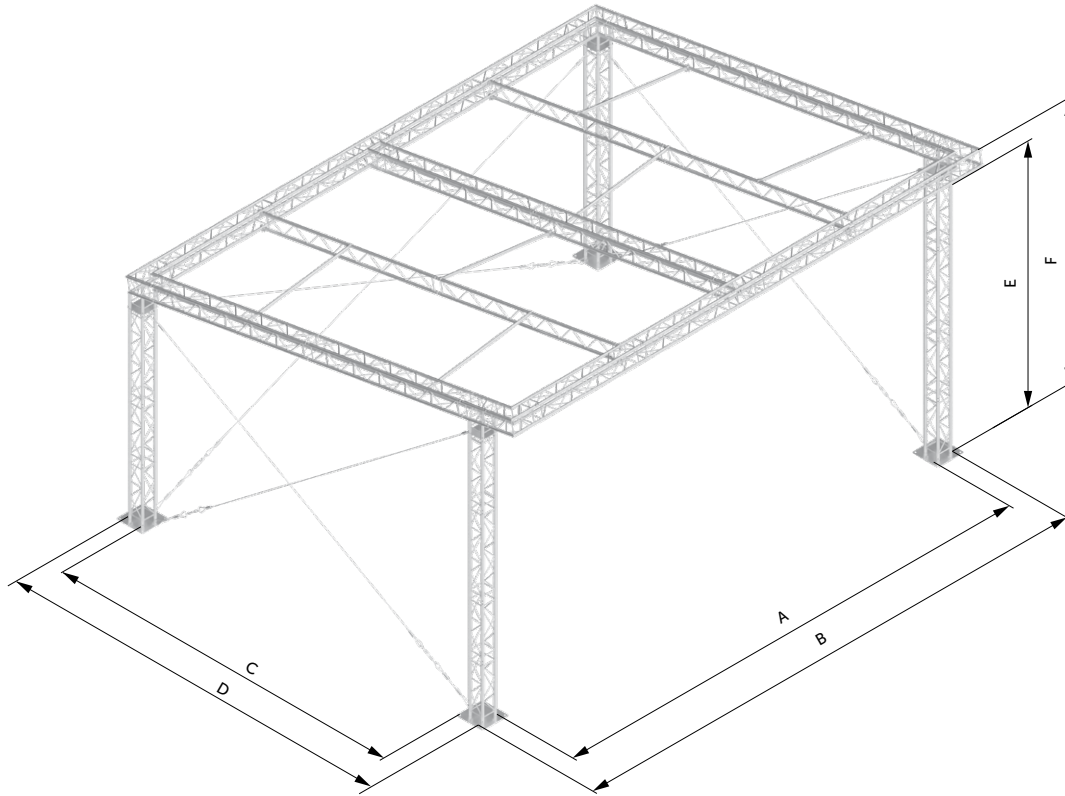

STAGE MEASUREMENTS

STAGE SIZE	Inside width	Overall width	Inside depth	Overall depth	Clearance	Height
	A	B	C	D	E	F
8 x 6 m (26.25 x 19.69 ft)	8.42 m (27.62 ft)	9 m (29.53 ft)	6.21 m (20.37 ft)	6.79 m (22.28 ft)	5.03 m (16.50 ft)	5.32 m (17.45 ft)

WIND MANAGEMENT

Wind resistance is calculated with 3 side mesh canopies applied to the structure (2 side canopies and one rear canopy). The three roof walls with canopies must be secured by guy wire cross bracing at all times with a min. loading capacity of 750 kg (1,654 lbs).

In service max. windspeed - 15 m/s - 54 km/h - 33 mph

Out of service max. windspeed - 28 m/s - 101 km/h - 62 mph

BALLAST

Min. ballast for each tower base	1500 kg (3,307 lbs)
Total ballast	6000 kg (13,228 lbs)

The ballast must be applied for secure usage of this roof system.

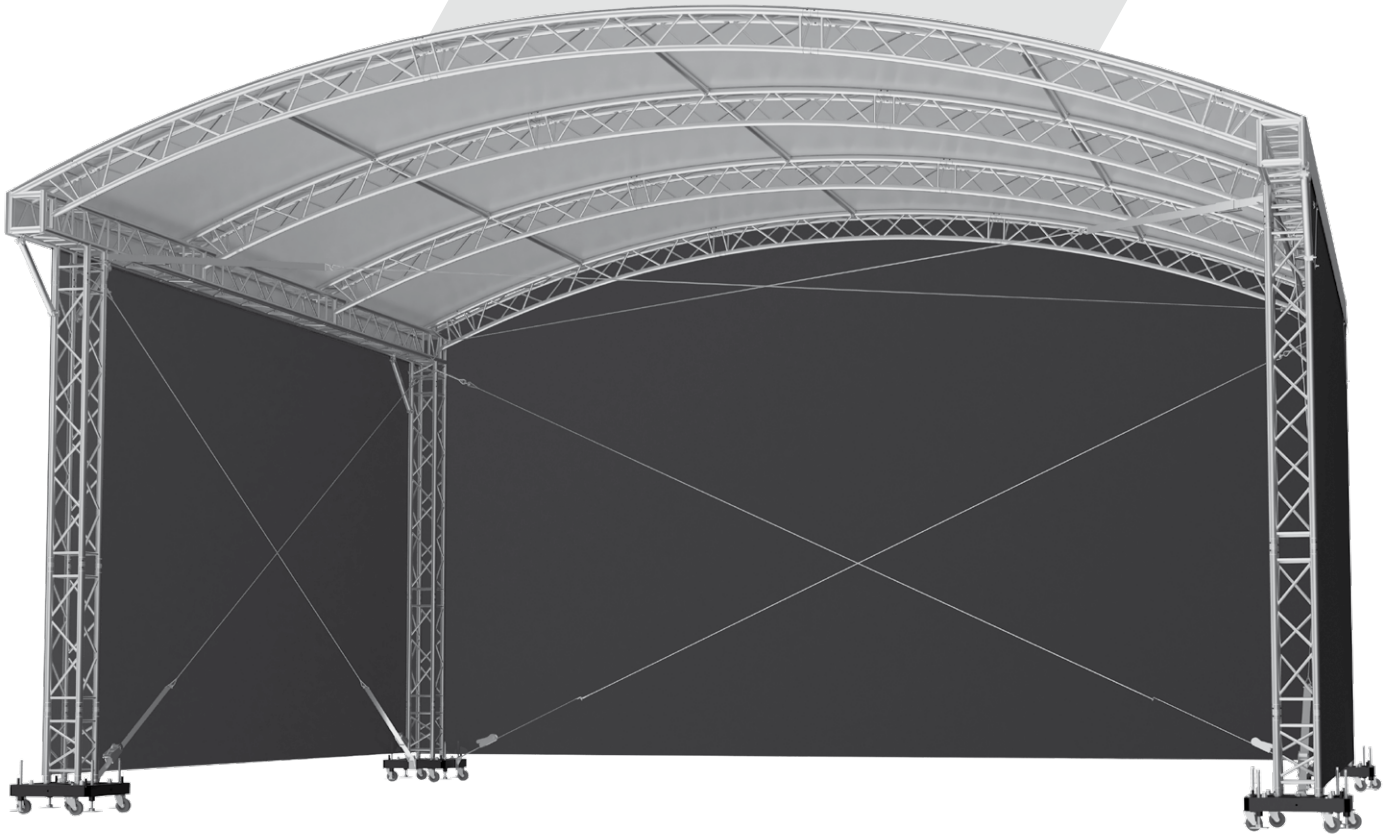

ROOF 1

Roof 1 is an arch roof system designed to cover stages up to 8 x 6 m (26 x 19.5 ft). Its attractive look is great for small to middle size events, such as concerts, fashion and entertainment shows, theatrical performances, and many others. Roof 1 is a great choice, as its dynamic look lends yet another stylish point to your show.

USED CONSTRUCTION SYSTEMS

Mast section	HT34
Arcs	HT33

SPECIFICATIONS

Max. dimensions	8.58 x 7.51 m (28.15 x 24.61 ft)
Max. clearance	4.9 m (16 ft)
Max. height	5.2 m (17 ft)
Max. load bearing capacity	1400 kg (3,087 lbs)
Total weight of construction	570 kg (1,257 lbs)

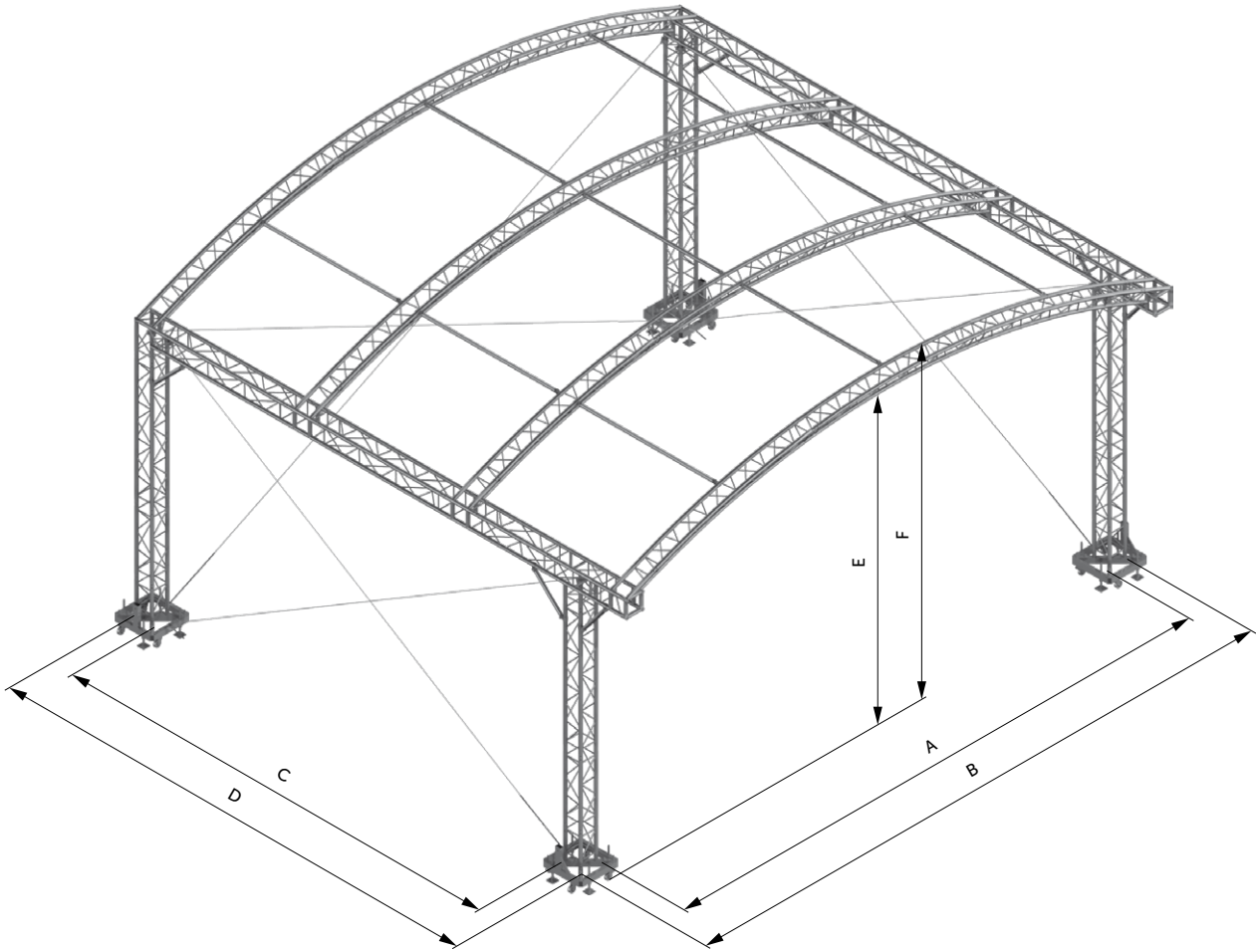

STAGE MEASUREMENTS

STAGE SIZE	Inside width	Overall width	Inside depth	Overall depth	Clearance	Height
	A	B	C	D	E	F
8 x 6 m (26.25 x 19.69 ft)	8 m (26.25 ft)	8.58 m (28.15 ft)	6.33 m (20.77 ft)	7.51 m (24.64 ft)	4.5 m (14.76 ft)	5.04 m (16.54 ft)

WIND MANAGEMENT

Wind resistance is calculated with 3 side mesh canopies applied to the structure (2 side canopies and one rear canopy). The three roof walls with canopies must be secured by guy wire cross bracing at all times as well as the top grid horizontal ceiling.

In service max. allowed windspeed - 20 m/s - 72 km/h - 45 mph

BALLAST

Min. ballast for each tower base	1270 kg (2,800 lbs)
Total ballast	5080 kg (11,199 lbs)

The ballast must be applied for secure usage of this roof system.

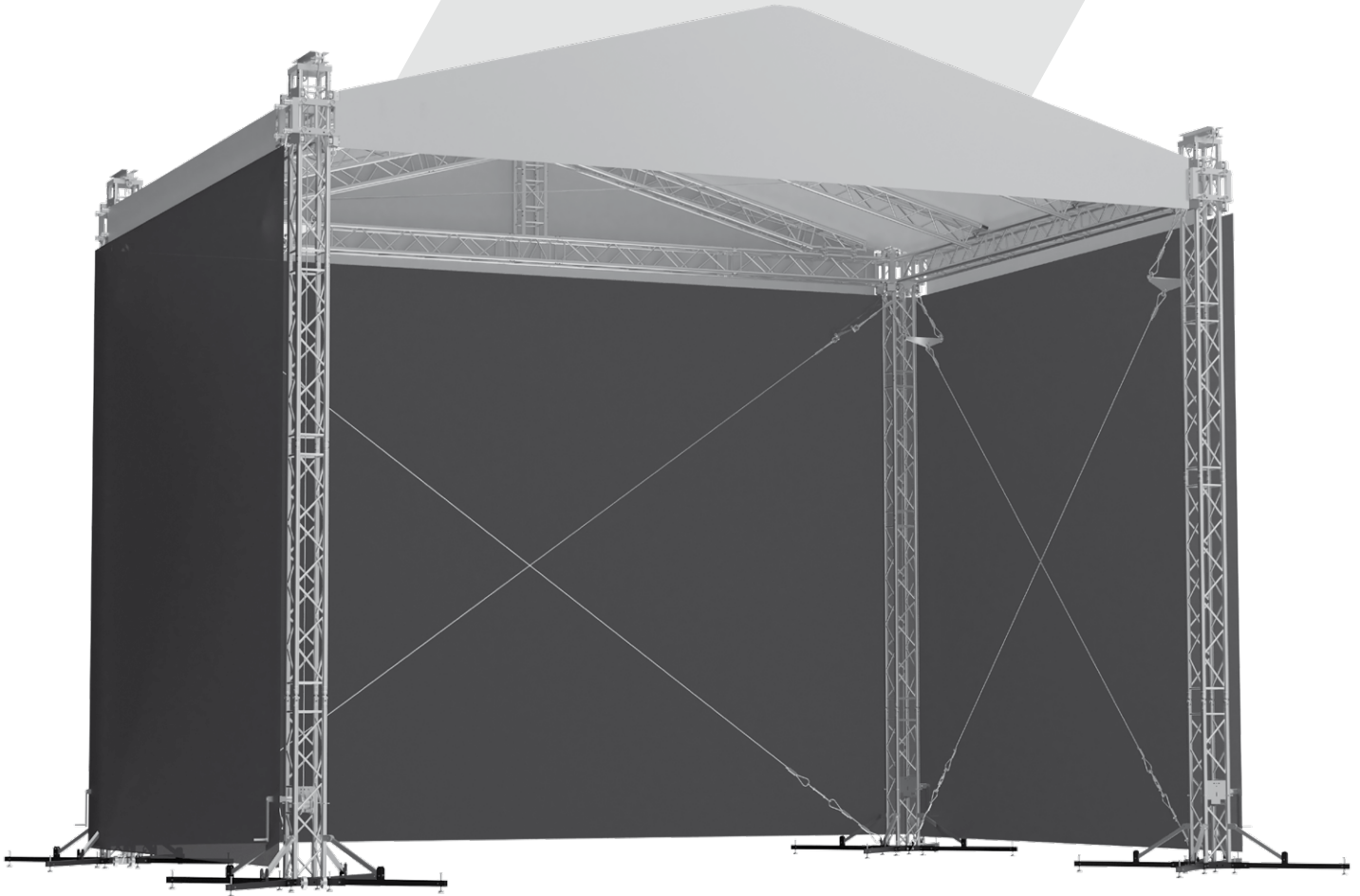

ROOF GB 8 x 6 m

Gable Roof 8 x 6 m is a great option for covering smaller size events. Its maximum loading of 2000 kg (4,409 lbs) and clearance of 6.1 m (20 ft) gives you enough space for any show. It is very easy to assemble, as the columns are from Tower 05, which is a self-contained unit constructed from HT34 truss.

USED CONSTRUCTION SYSTEMS

Mast section	HT34
Support truss	FT34
Rafters	FT33
Tower	Tower 05

SPECIFICATIONS

Max. dimensions	10.3 x 7.8 m (33.79 x 25.59 ft)
Max. load bearing capacity	2000 kg (4,409 lbs)
Total weight of construction	600 kg (1,323 lbs)

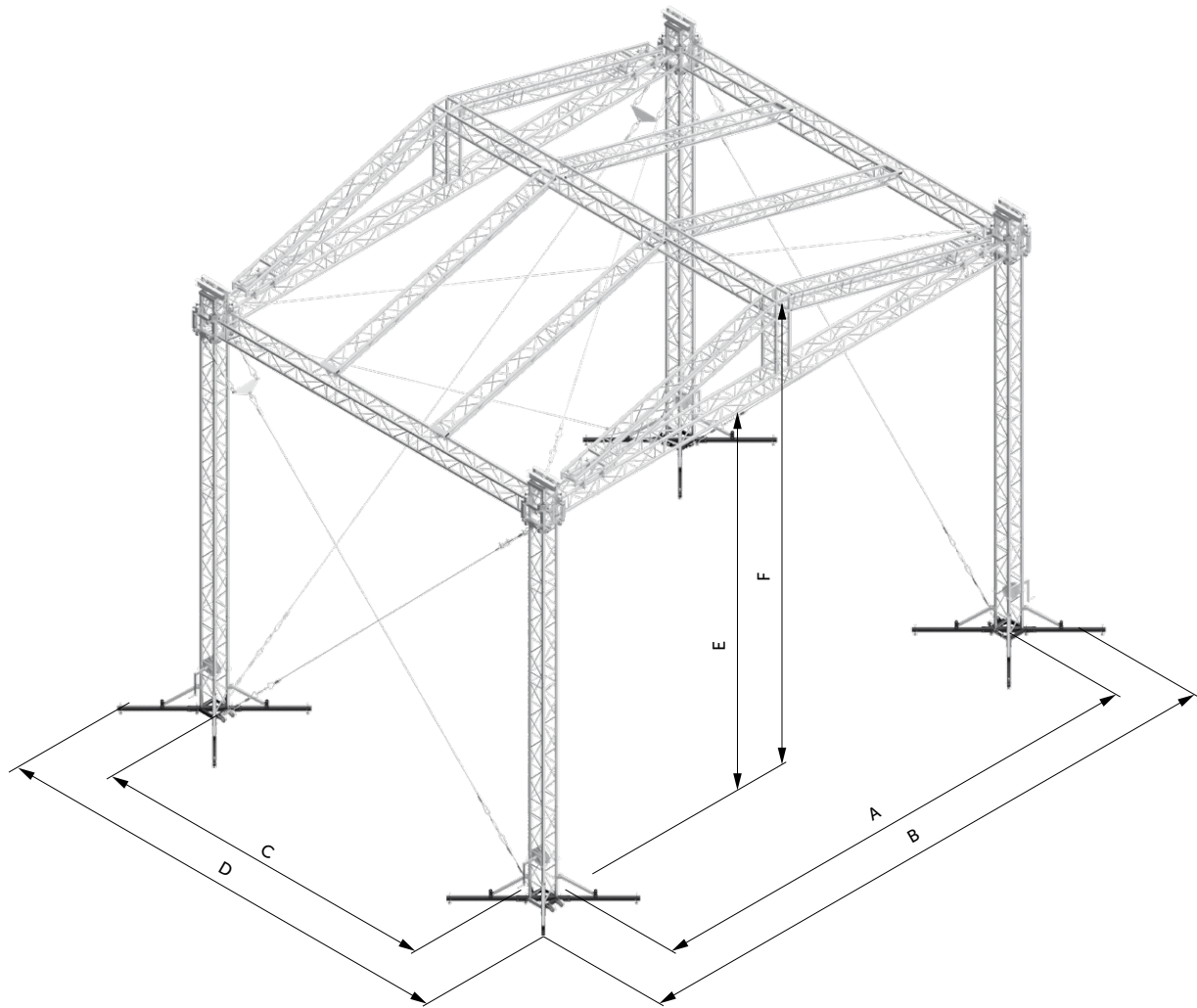

STAGE MEASUREMENTS

STAGE SIZE	Inside width	Overall width	Inside depth	Overall depth	Clearance	Height
	A	B	C	D	E	F
8 x 6 m (26.25 x 19.69 ft)	8.2 m (26.90 ft)	8.8 m (28.87 ft)	5.72 m (18.77 ft)	6.3 m (20.67 ft)	6.1 m (20.01 ft)	7.53 m (24.70 ft)

WIND MANAGEMENT

Wind resistance is calculated with 3 side mesh canopies applied to the structure (2 side canopies and one rear canopy). The three roof walls with canopies must be secured by guy wire cross bracing at all times as well as the top grid horizontal ceiling.

In service max. allowed windspeed - 20 m/s - 72 km/h - 45 mph

BALLAST

Min. ballast for each tower base	1450 kg (3,197 lbs)
Total ballast	5800 kg (12,787 lbs)

The ballast must be applied for secure usage of this roof system.

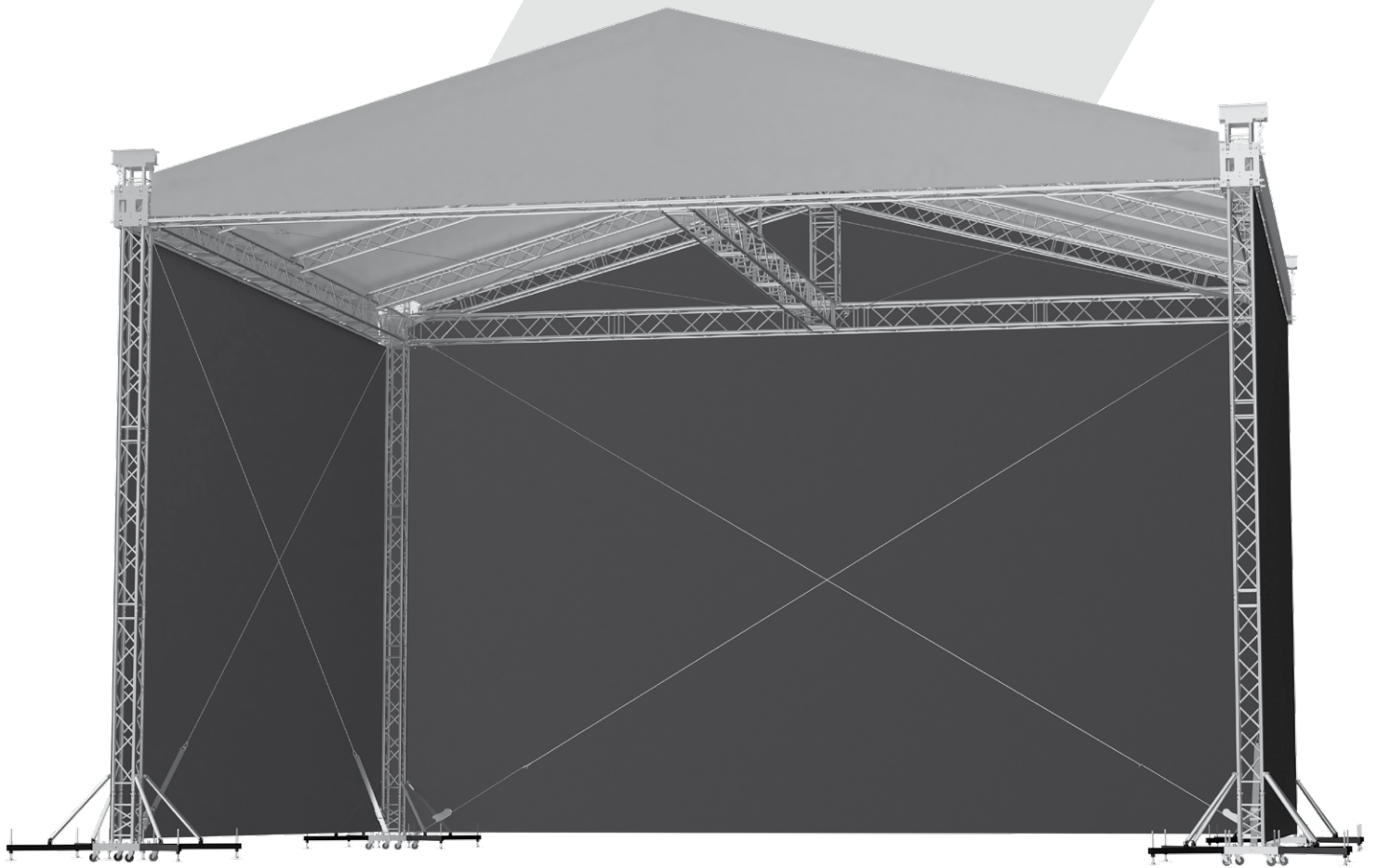

ROOF 2

Roof 2 is the best-selling roof system in our portfolio. The structure is available in three different dimensions, which cover the following stage sizes - 12 x 10 m (39 x 32.5 ft), 10 x 8 m (32.5 x 26 ft), and 8 x 6 m (26 x 19.5 ft). Its fast and easy assembly makes Roof 2 a great choice for almost any kind of event.

USED CONSTRUCTION SYSTEMS

Mast section	TT34
Support truss	FT44
Outside rafter	FT34
Inside rafter	FT33

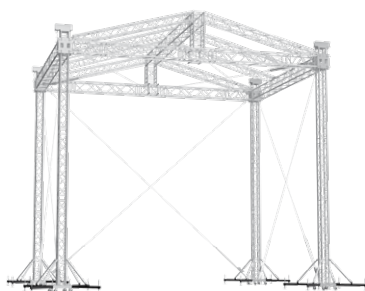

ROOF 2 8 x 6 m

Max. load bearing capacity	3500 kg (7,716 lbs)
Total weight	1630 kg (3,594 lbs)

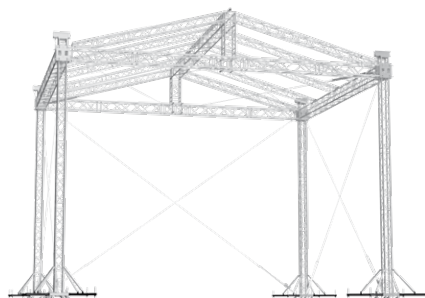

ROOF 2 10 x 8 m

Max. load bearing capacity	3500 kg (7,716 lbs)
Total weight	1915 kg (4,222 lbs)

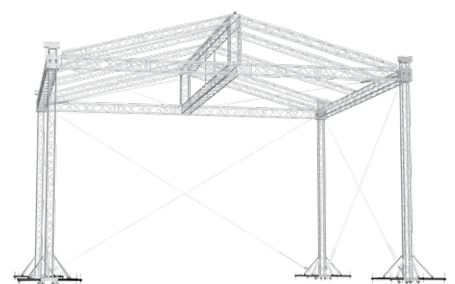

ROOF 2 12 x 10 m

Max. load bearing capacity	3500 kg (7,716 lbs)
Total weight	2040 kg (4,497 lbs)

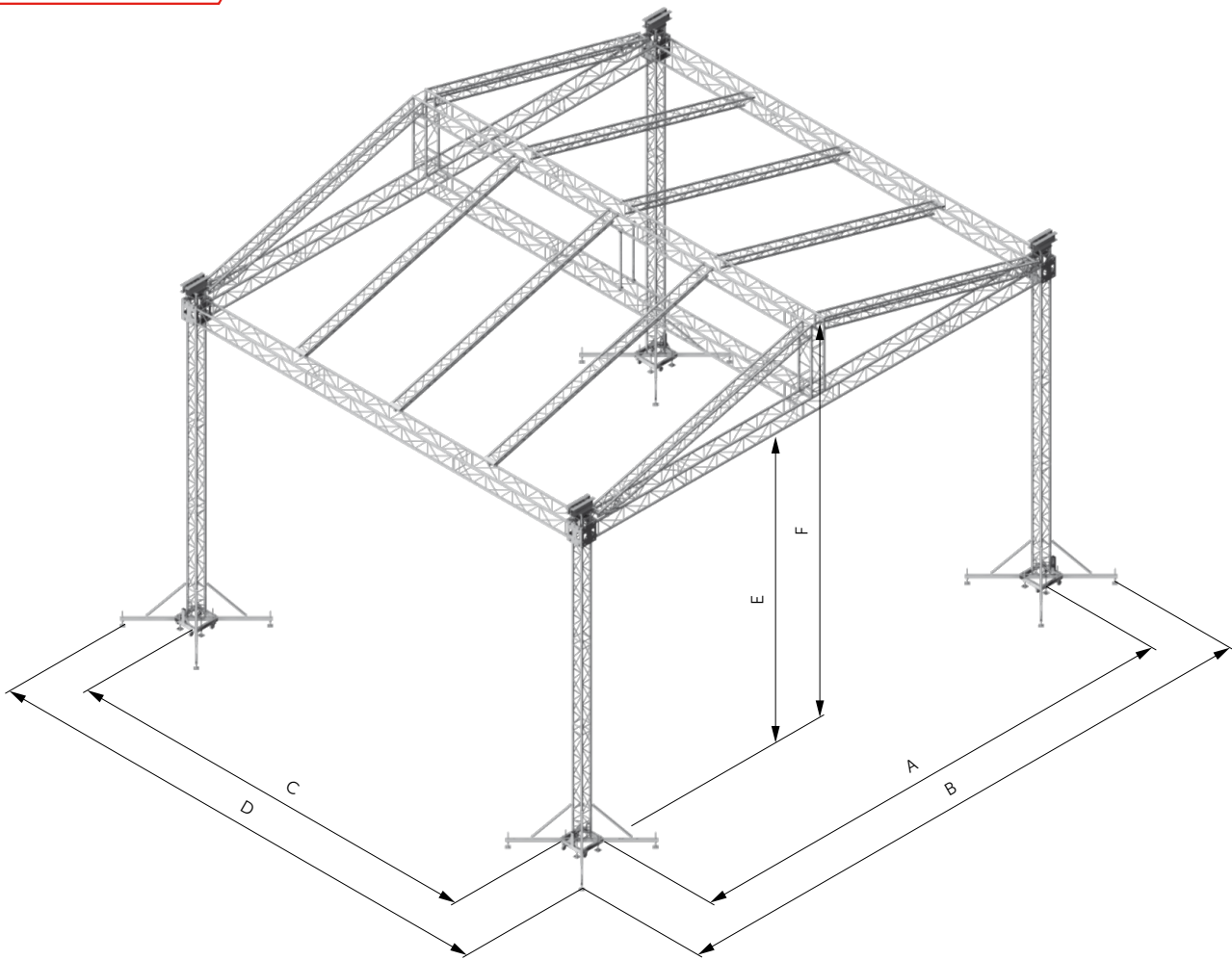

STAGE MEASUREMENTS

STAGE SIZE	Inside width	Overall width	Inside depth	Overall depth	Clearance	Height
	A	B	C	D	E	F
8 x 6 m (26.25 x 19.69 ft)	8.14 m (26.70 ft)	10.5 m (34.45 ft)	6.39 m (20.96 ft)	8.75 m (28.71 ft)	7 m (22.97 ft)	8.57 m (28.12 ft)
10 x 8 m (32.81 x 26.25 ft)	10.14 m (33.26 ft)	12.5 m (41.01 ft)	8.39 m (27.53 ft)	10.75 m (35.27 ft)	7 m (22.97 ft)	8.94 m (29.31 ft)
12 x 10 m (39.37 x 32.81 ft)	12.14 m (39.82 ft)	14.5 m (47.27 ft)	10.39 m (34.09 in)	12.75 m (41.83 ft)	7 m (22.97 ft)	9.2 m (30.17 ft)

WIND MANAGEMENT

Wind resistance is calculated with 3 side mesh canopies applied to the structure (2 side canopies and one rear canopy). The three roof walls with canopies must be secured by guy wire cross bracing at all times as well as the top grid horizontal ceiling.

In service max. allowed windspeed - 20 m/s - 72 km/h - 45 mph

BALLAST

	8 x 6 m (26.25 x 19.69 ft)	10 x 8 m (32.81 x 26.25 ft)	12 x 10 m (39.37 x 32.81 ft)
Ballast underneath each tower base	2100 kg (4,630 lbs)	2200 kg (4,850 lbs)	2800 kg (6,173 lbs)
Total ballast	8400 kg (18,519 lbs)	8800 kg (19,401 lbs)	11 200 kg (24,692 lbs)

The ballast must be applied for secure usage of this roof system.

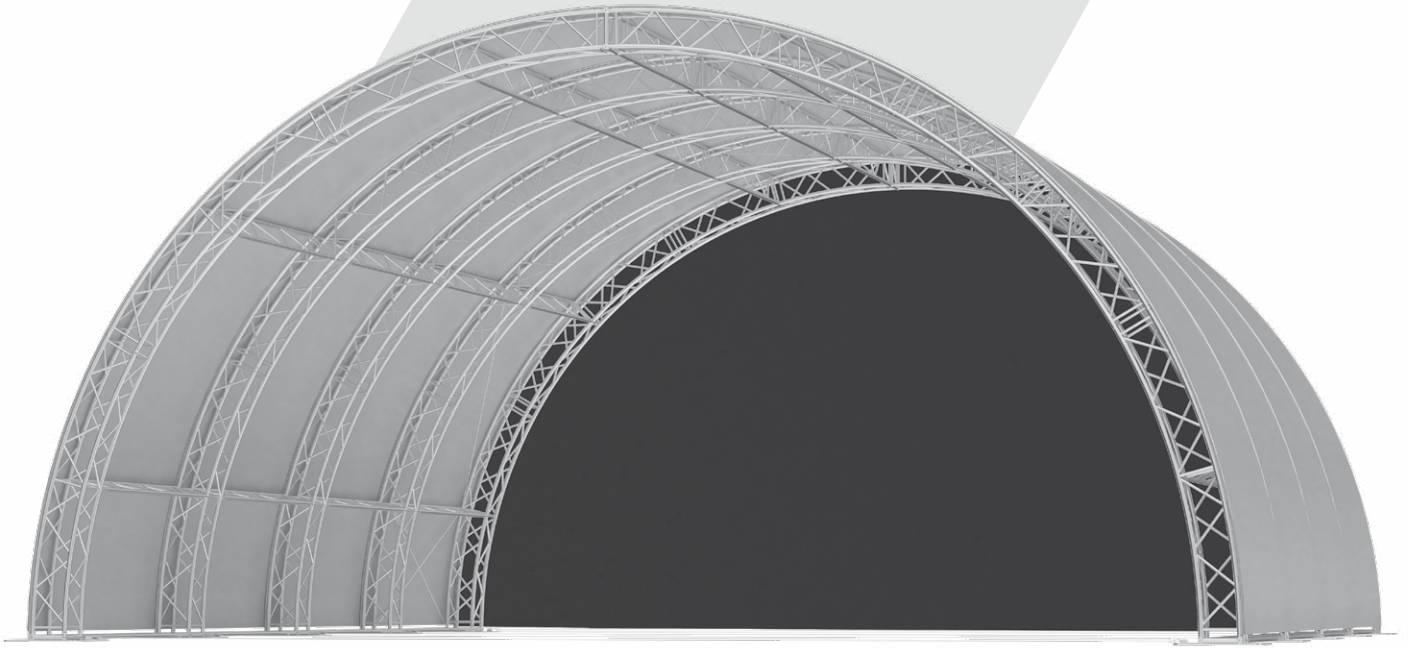

ROOF ARC 12 x 12 x 6 m

Roof Arc 12 x 12 x 6 m (39.37 x 39.37 x 19.67 ft) is a tunnel roof system made of five aluminium truss arches. The tunnel design of temporary roofs provides extreme versatility for event management and show planning, as the arches feature impressive clearance and, at the same time, high loading capacity.

USED CONSTRUCTION SYSTEMS

Arcs	HT44
Rafters	HT42

SPECIFICATIONS

Max. dimension	12.5 x 12.5 m (41 x 41 ft)
Max. stage size	11 x 11 m (36.1 x 36.1 ft)
Max. clearance	4.6 m (15.1 ft)
Max. height	6.07 m (21.98 ft)
Max. load bearing capacity	10 000 kg (22,046 lbs)
Total weight of construction	2150 kg (4,739 lbs)

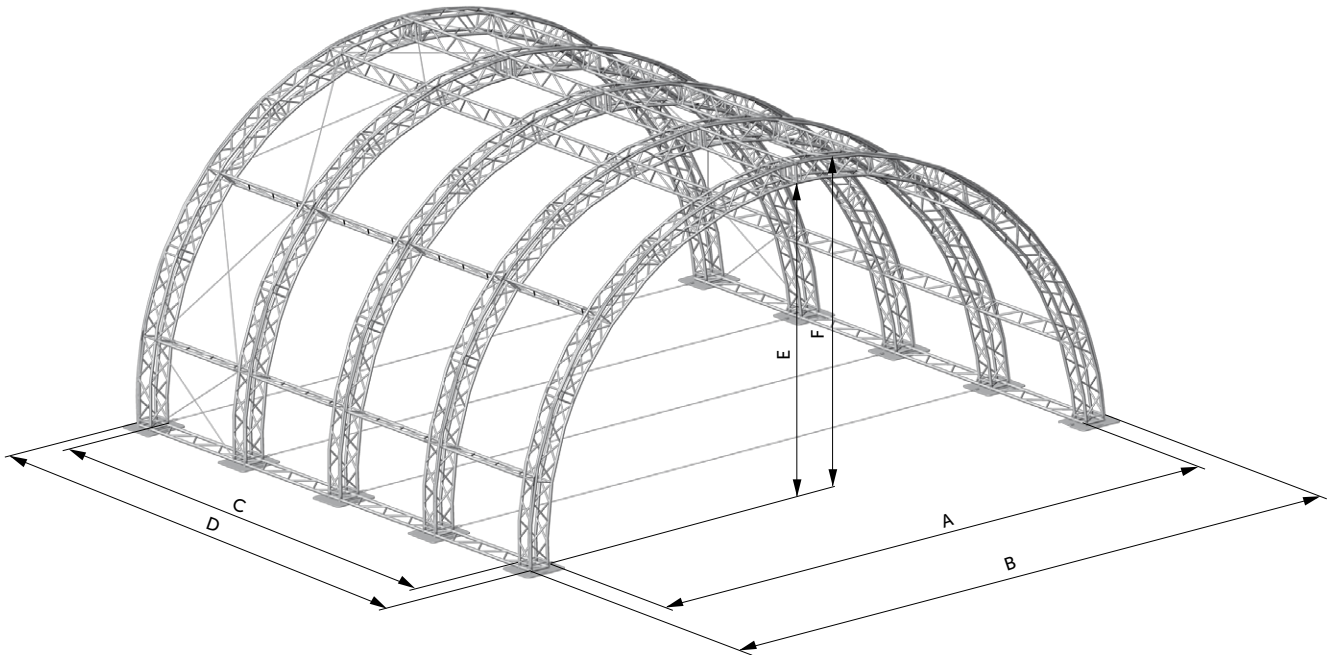

STAGE MEASUREMENTS

STAGE SIZE	Inside width	Overall width	Inside depth	Overall depth	Clearance	Height
	A	B	C	D	E	F
11 x 11 m (36.09 x 36.09 ft)	11.25 m (36.91 ft)	12.45 m (40.85 ft)	12 m (39.37 ft)	12.4 m (40.68 ft)	5.67 m (18.59 ft)	6.09 m (19.96 ft)

WIND MANAGEMENT

Wind resistance is calculated with PVC canopy stripes applied to the structure creating a fully covered structure from the top side (front and rear walls of the tunnel are open). The last arched section of roof must be secured by guy wire cross bracing at all times as well as the bottom steel base plates connected to each other by steel rope bowstrings.

In service max. allowed windspeed - 20 m/s - 72 km/h - 45 mph.

BALLAST

12 x 12 x 6 m (39.37 x 39.37 x 19.69 ft)	
Min. ballast for each base plate	2600 kg (5,732 lbs)
Total ballast	26 000 kg (57,320 lbs)

All base plates must be lain on the ground at all time.

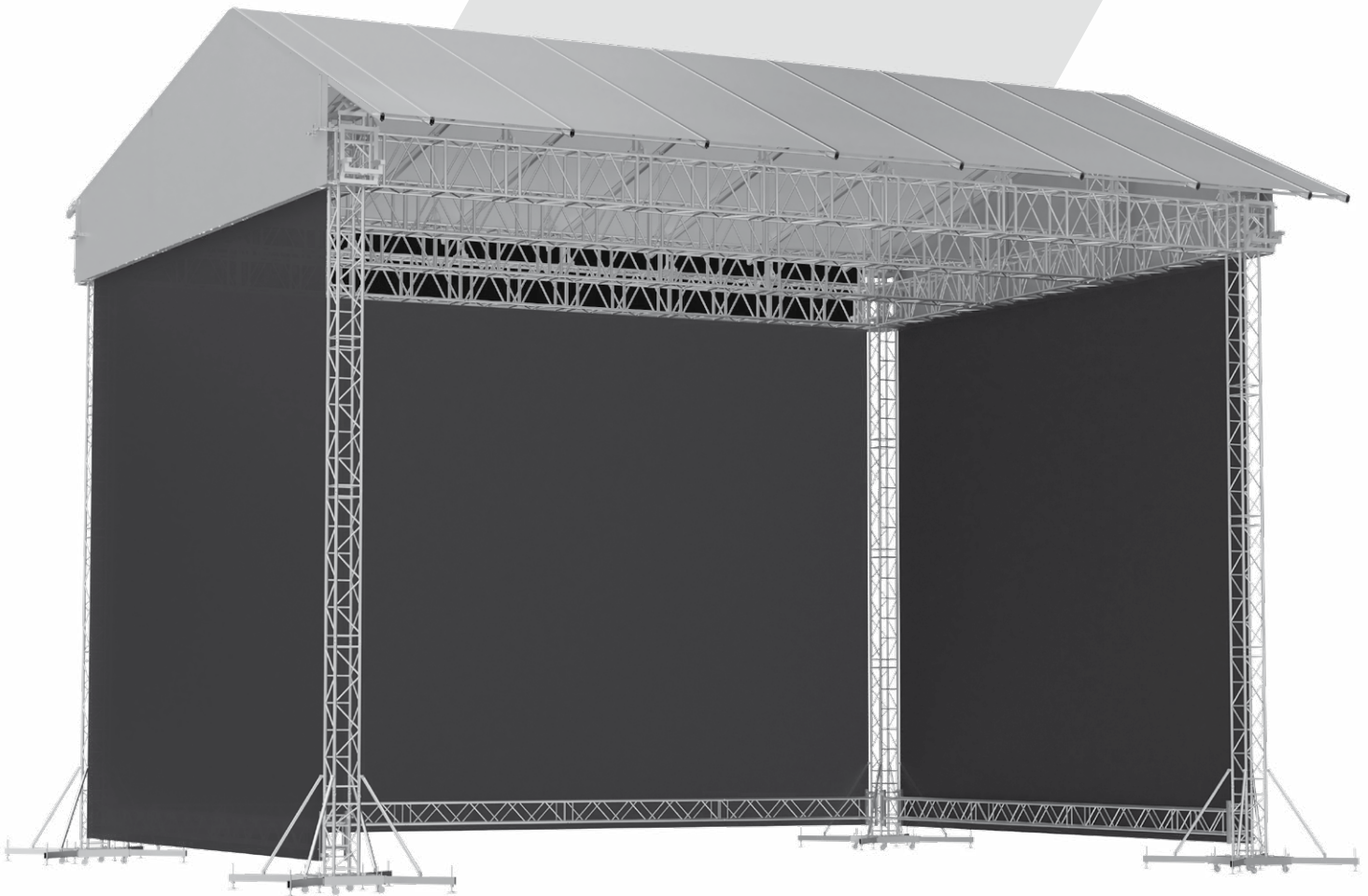

ROOF KD 14 x 10 x 9 m

Keder profile top roofs are very popular systems for rental businesses. TAF's 14 x 10 x 9 m (45.93 x 32.81 x 29.53 ft) keder roof can bear up to 5000 kg (11,023 lbs) and covers stages up to 14 x 10 m. The keder top is a lightweight solution for covering the stage with canopy strips. The overall design of the roof is ready to accommodate as many lights and sound systems as you need.

USED CONSTRUCTION SYSTEMS

Mast section	TT44
Support truss	TT74M
Rafter	Keder Profile

SPECIFICATIONS

Max. dimension	17.0 x 13.4 m (55.9 x 44.0 ft)
Max. stage size	14 x 10 m (45.9 x 32.81 ft)
Max. clearance	9.0 m (29.5 ft)
Max. height	12.0 m (39.5 ft)
Max. load bearing capacity	5000 kg (11,023 lbs)
Total weight of construction	4100 kg (9,039 lbs)

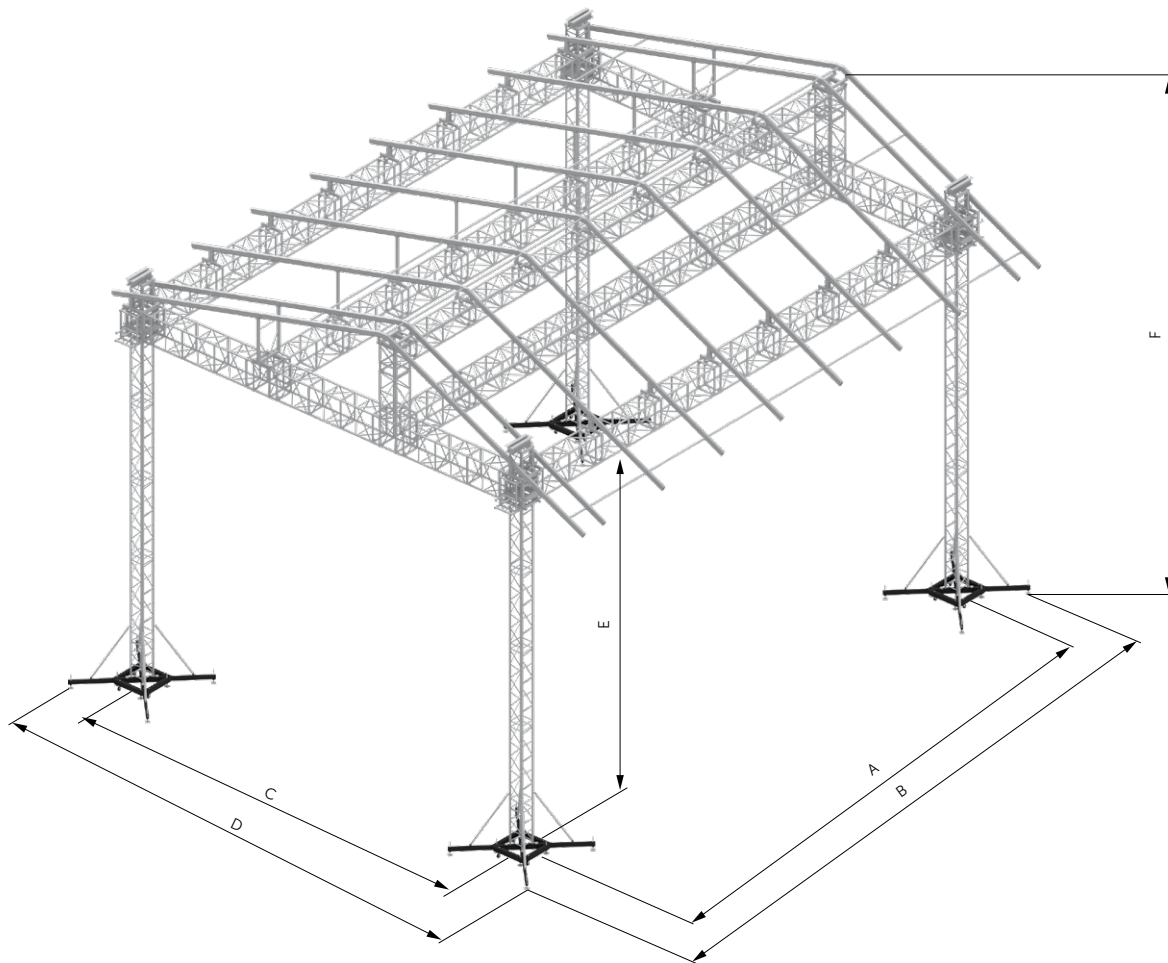

STAGE MEASUREMENTS

STAGE SIZE	Inside width	Overall width	Inside depth	Overall depth	Clearance	Height
	A	B	C	D	E	F
14 x 10 m (45.93 x 32.81 ft)	14.29 m (46.88 ft)	17.04 m (55.91 ft)	10.67 m (35.01 ft)	13.42 m (44.03 ft)	9 m (29.53 ft)	12.03 m (39.47 ft)

WIND MANAGEMENT

Wind resistance is calculated with 3 side mesh canopies applied to the structure (2 side canopies and one rear canopy). The three roof walls carrying canopies must be secured by guy wire cross bracing at all times as well as the top grid horizontal ceiling.

In service max. allowed windspeed - 20 m/s - 72 km/h - 45 mph

BALLAST

ROOF KD 14 x 10 x 9 m	
Min. ballast for each tower base	5300 kg (11,685 lbs)
Total ballast	21 200 kg (46,738 lbs)

All base plates must be lain on the ground at all time.

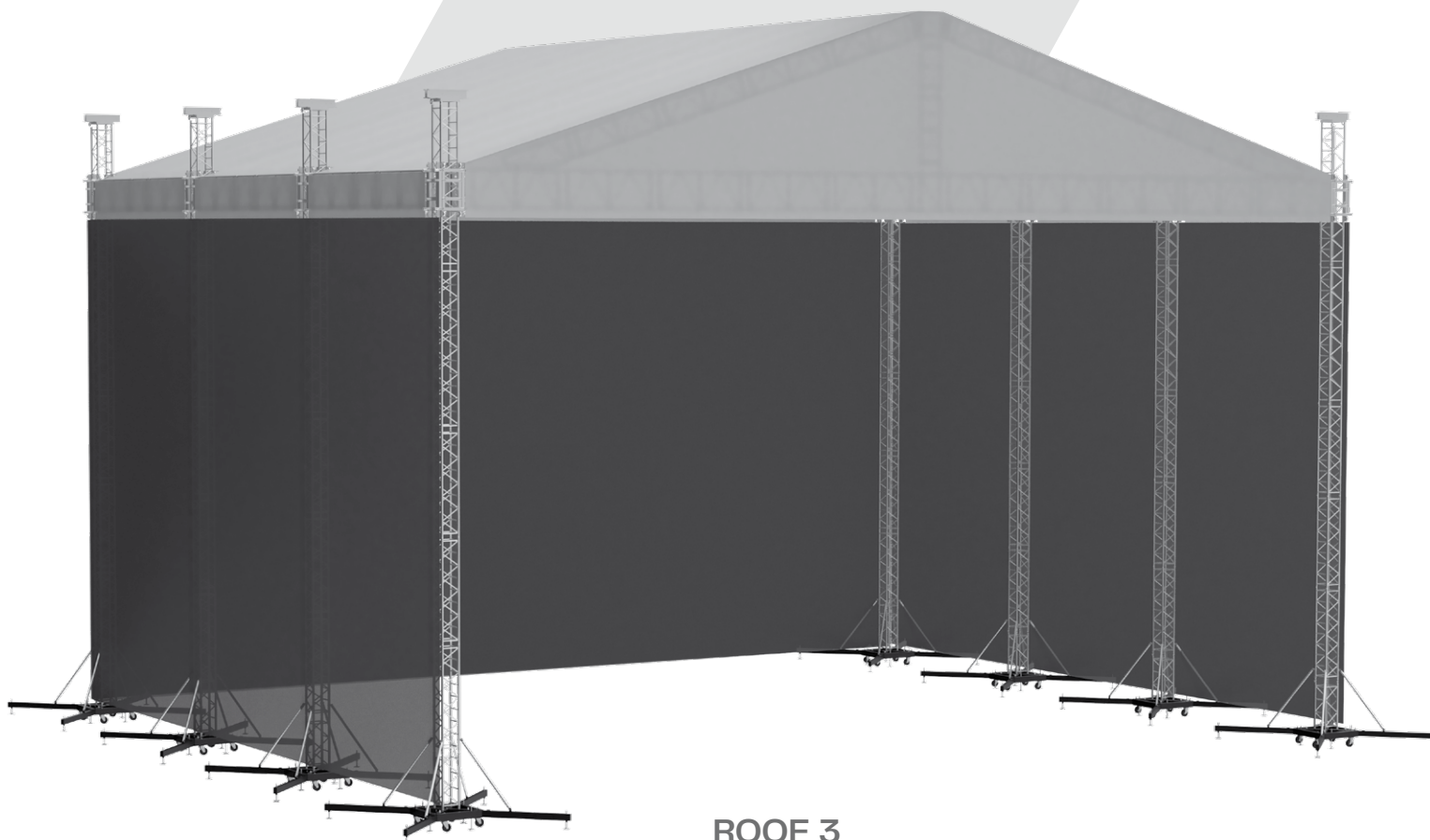

ROOF 3

Roof 3 can cover areas from 120 m² to 320 m² (1,291.7 ft² to 3,444.4 ft²), depending on your needs. Roof 3 covers a max. stage size of 21 x 16.5 m (68.5 x 52 ft).

USED CONSTRUCTION SYSTEMS

Mast section	TT44
Support truss	TT74M, TT54M
Outside rafter	FT44
Inside rafter	FT43

SPECIFICATIONS

Max. dimension	25 x 20 m (82.02 x 65.62 ft)
Max. stage size	21 x 16.5 m (68.9 x 64.1 ft)
Max. clearance	11.5 m (37.7 ft)
Max. height	15.5 m (50.8 ft)
Max. load bearing capacity	12 500 kg (27,558 lbs)

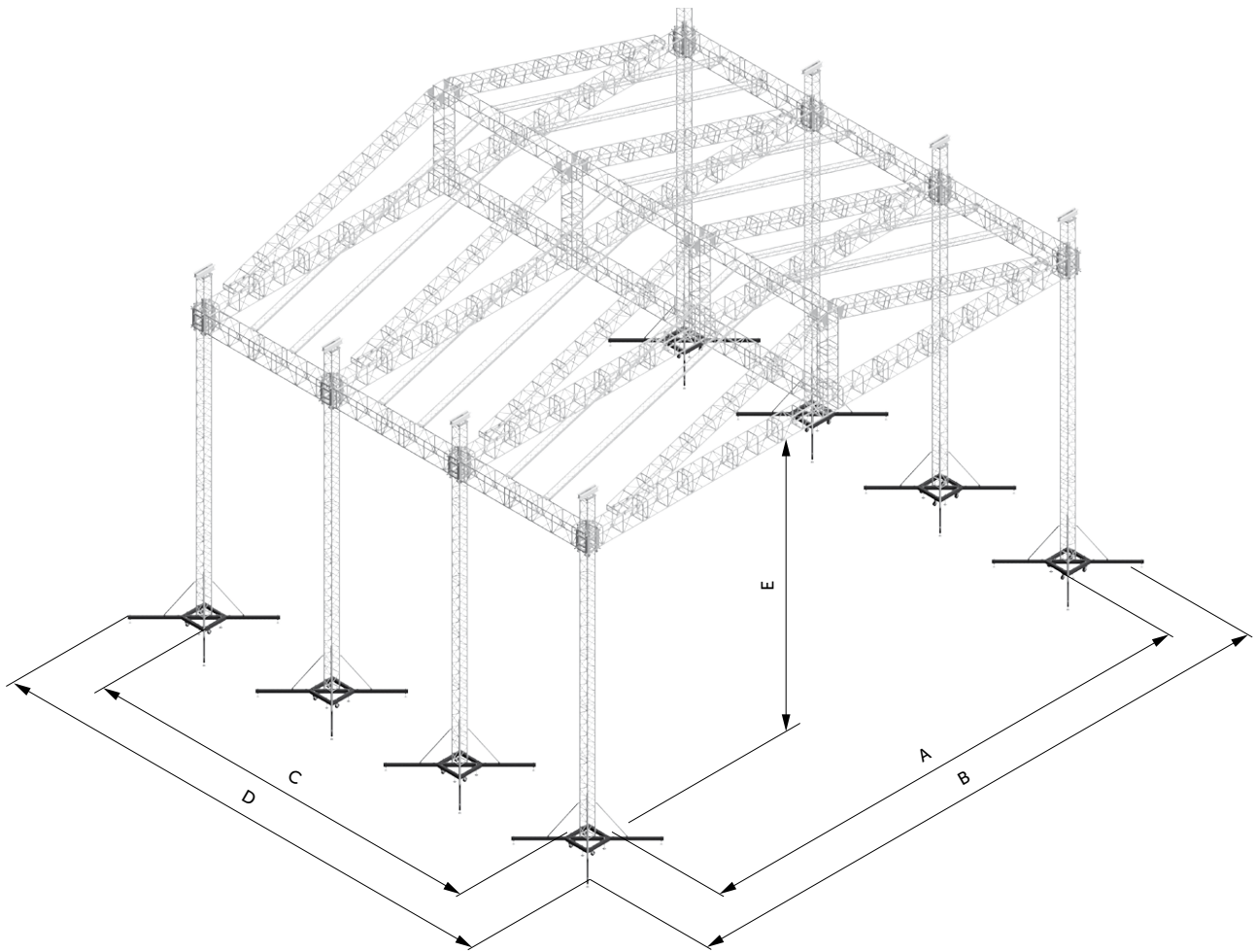

STAGE MEASUREMENTS

STAGE SIZE	Inside width	Overall width	Inside depth	Overall depth	Clearance
	A	B	C	D	E
21 x 16.5 m (68.9 x 64.1 ft)	21 m (68.9 ft)	25 m (82.02 ft)	16.7 m (54.8 ft)	20 m (65.6 ft)	11.5 m (37.7 ft)

WIND MANAGEMENT

In service max. allowed windspeed - 20 m/s - 72 km/h - 45 mph

At TAF, we pride ourselves on crafting custom roofs that seamlessly combine durability, functionality, and a bespoke design. Our expertise lies in creating roof solutions tailored to your specific needs.

Whether you require roofs with special dimensions, or unique specifications, we have the experience and knowledge to deliver exactly what you envision. No matter the scale or complexity of your project, our team ensures precision engineering and exceptional quality every step of the way.

Partner with TAF for all of your roofing needs. Your vision, our expertise. Together, we build better.

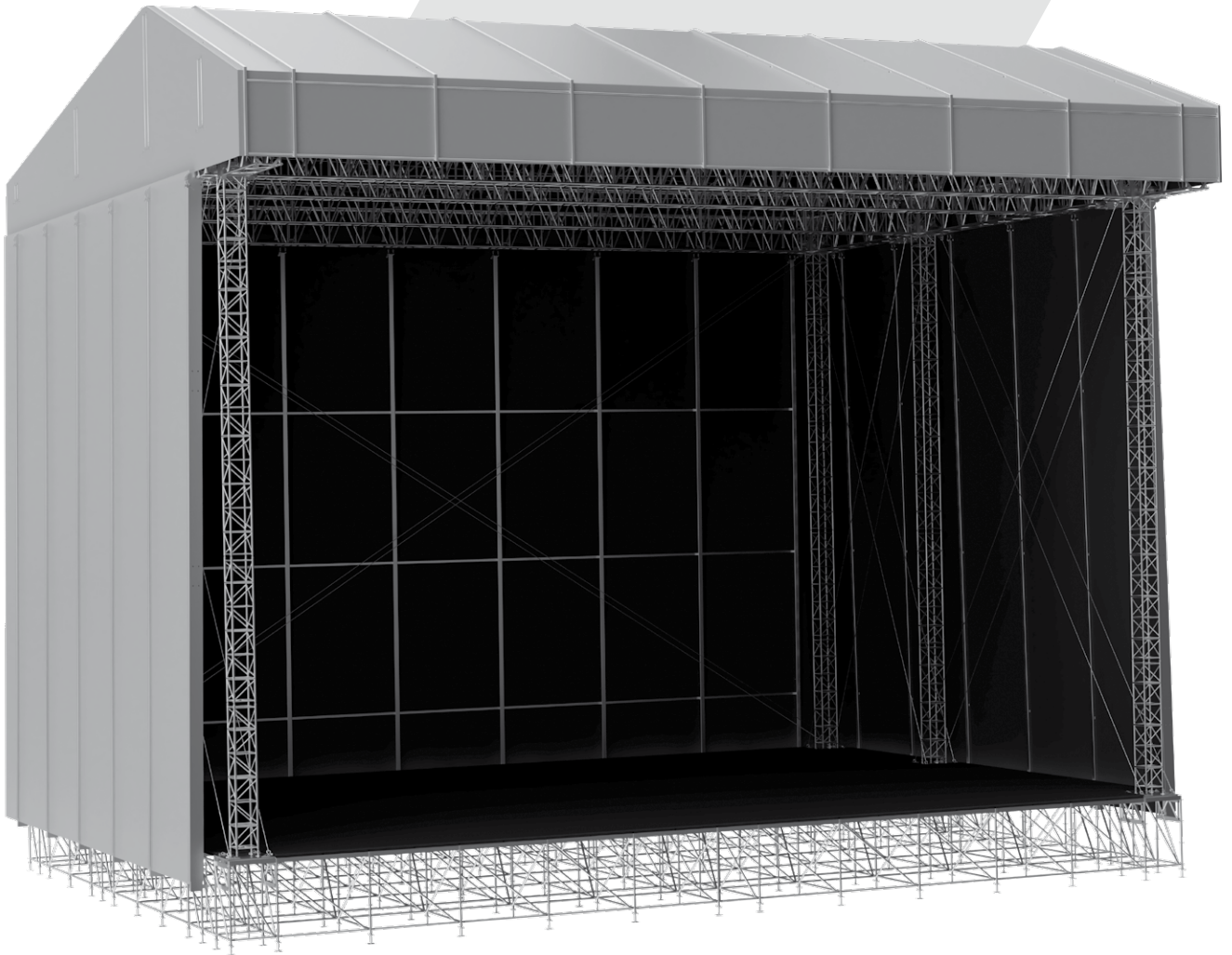

ROOF 4

Roof 4 is a reliable and versatile solution designed for a variety of events and outdoor applications. Built with durable TT104M truss, this system offers exceptional strength and stability, ensuring it meets the demands of large-scale setups. The addition of a high-quality keder profile enhances the roof system, allowing for precise and secure attachment of covers, providing excellent weather resistance and a sleek finish. Whether you're hosting concerts, exhibitions, or temporary installations, Roof 4 delivers professional-grade reliability and aesthetic appeal. It's the perfect combination of durability, efficiency, and ecological innovation.

USED CONSTRUCTION SYSTEMS

Mast section	TT54TM
Support truss	TT104M
Rafter	Keder profile

SPECIFICATIONS

Max. dimension	24.1 x 19.8 m (79.07 x 64.96 ft)
Max. height	20 m (65.62 ft)
Max. load bearing capacity	19 000 kg (41,888 lbs)*

*Loading is valid only when 5 cantilever bridges are used. The calculation comply with EN 13814 regulations taking into account the wind loads.

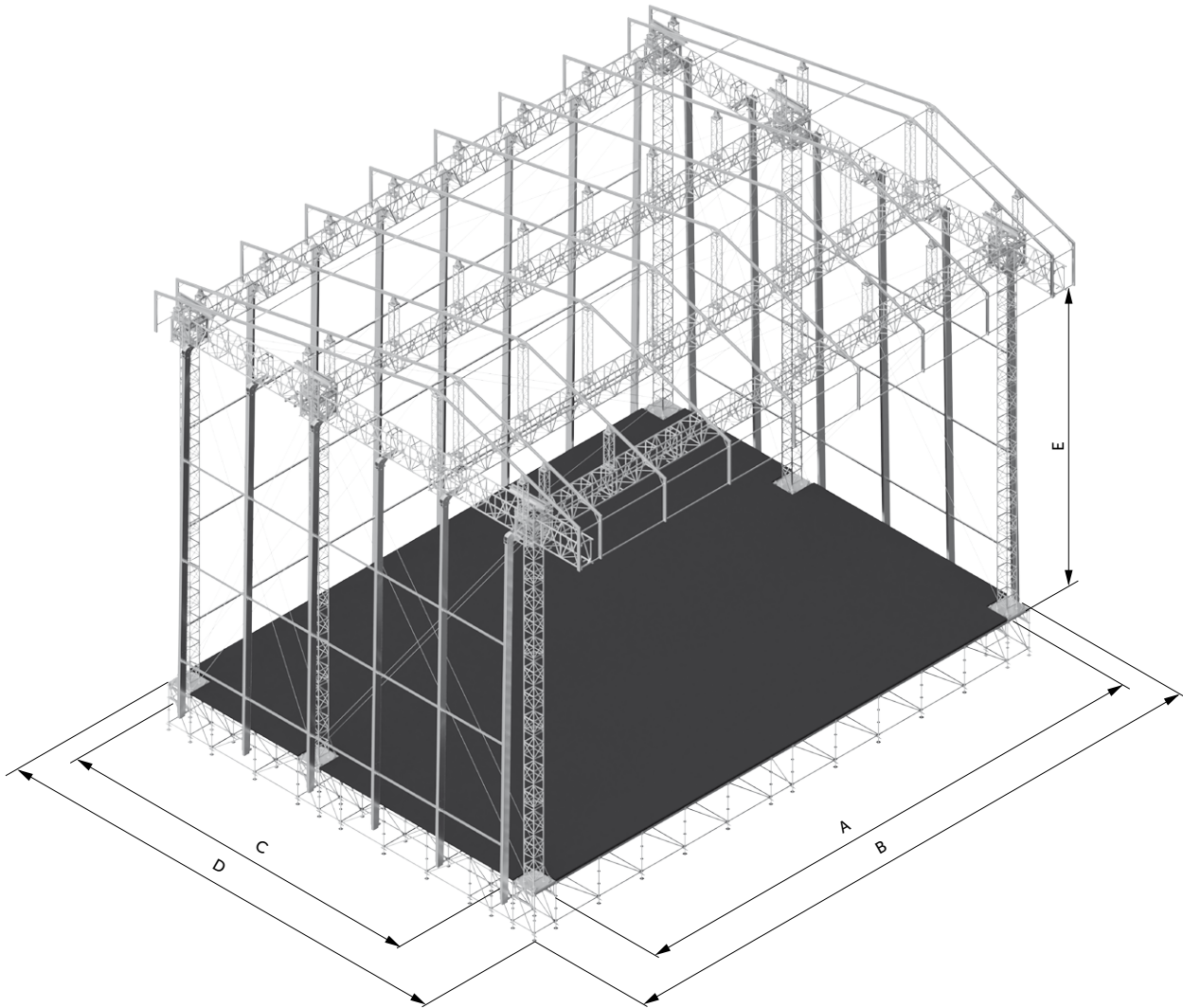

STAGE MEASUREMENTS

STAGE SIZE	Inside width	Overall width	Inside depth	Overall depth	Clearance
	A	B	C	D	E
23 x 17 m (75.46 x 55.77 ft)	23 m (75.46 ft)	24.1 m (79.07 ft)	17 m (55.77 ft)	19.8 m (64.96 ft)	13.8 m (45.28 ft)

WIND MANAGEMENT

In service max. allowed windspeed - 20 m/s - 72 km/h - 45 mph

At TAF, we pride ourselves on crafting custom roofs that seamlessly combine durability, functionality, and a bespoke design. Our expertise lies in creating roof solutions tailored to your specific needs.

Whether you require roofs with special dimensions, or unique specifications, we have the experience and knowledge to deliver exactly what you envision. No matter the scale or complexity of your project, our team ensures precision engineering and exceptional quality every step of the way.

Partner with TAF for all of your roofing needs. Your vision, our expertise. Together, we build better.

STAGES STH



STH Stages represent an upgrade from our standard ST stages in many ways. They are rated for 750 kg/m² (154 lbs/ft²) and feature our popular hexa anti-slip surface. The main advantages of these stages are their weight, only 32 kg (71 lbs), durability and easy assembly. Another important feature is their ability to accommodate various types of legs – 48.3 mm (1.9 in) round legs, 50 x 50 mm (1.97 x 1.97 in) square legs, and 60 x 60 mm (2.36 x 2.36 in) square legs, and all without changing the pressure cube system inside the corner.

750 kg/m²
(154 lbs/ft²)



STH-1

Top	Black hexa plywood
Dimensions	1 x 2 m (3.28 x 6.56 ft)
Loading capacity	750 kg/m ² (154 lbs/ft ²)
Weight	32 kg (71 lbs)
Height	9 cm (3.54 in)



STH-2

Top	Black hexa plywood
Dimensions	1 x 1 m (3.28 x 3.28 ft)
Loading capacity	750 kg/m ² (154 lbs/ft ²)
Weight	16 kg (35.27 lbs)
Height	9 cm (3.54 in)

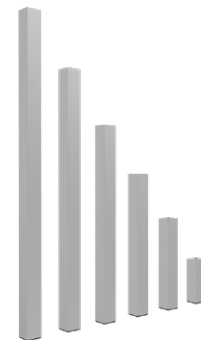

STH-2

Standard fixed leg for STH stages	
Round profile	48 x 48 x 3 mm (1.58 x 1.58 x 0.01 in)
Round profile	50 x 50 x 3 mm (1.97 x 1.97 x 0.01 in)
Square profile	60 x 60 x 2 mm (2.36 x 2.36 x 0.01 in)



STH-L-T

Square telescopic legs
0.4-1.8 m (1.31-3.28 ft)

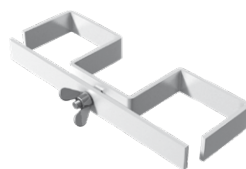

STH-ACC-1

Leg to leg connector for two legs

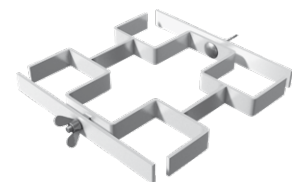

STH-ACC-2

Leg to leg connector for four legs

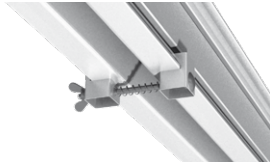

STH-CON

Deck to deck connector for strong and steady connection

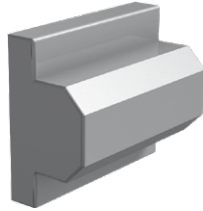
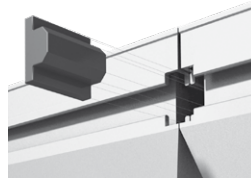

STH-ACC-4

Deck leveler



STH-RAIL-100

1 m (3.28 ft) handrail for STH

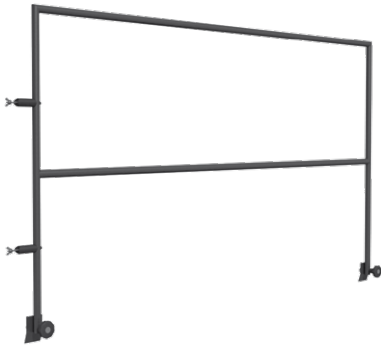

STH-RAIL-200

2 m (6.56 ft) handrail for STH

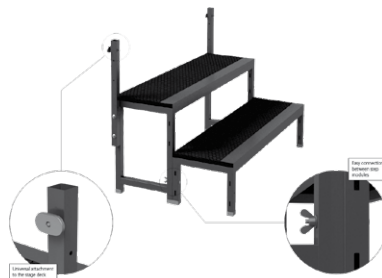

STH-STAIRS

Modular stairs 20 cm (7.87 in), 40 cm (1.31 ft), 60 cm (1.97 ft), 80 cm (2.63 ft)



STH-RAIL-S

Handrail for stairs



STH-STAIRS/ADJ

Adjustable stairs in various heights 0.4-1.8 m (1.31-3.28 ft)



STH-RAIL/ADJ

Handrail for adjustable stairs

BARRIERS

TAF Barriers are the right choice for controlling crowds, when necessary. The barriers are safety devices that can help you manage crowds at various types of events, such as pop concerts, music festivals, political meetings, etc.

The cable protectors can be used anywhere to provide protection for your cords and cables from walk-over pedestrian and car traffic.



BR1-B

Barrier base
 120 x 115 x 125 cm
 (47.24 x 45.28 x 49.21 in)
 41 kg (90 lbs)



BR1-G

Barrier gate
 120 x 115 x 125 cm
 (47.24 x 45.28 x 49.21 in)
 41 kg (90 lbs)



BR1-CGS

Barrier cable gate
 120 x 115 x 125 cm
 (47.24 x 45.28 x 49.21 in)
 40.35 kg (88.96 lbs)



BR1-V

Vario corner
 120 x 160 x 125 cm
 (47.24 x 62.99 x 49.21 in)
 48 kg (106 lbs)

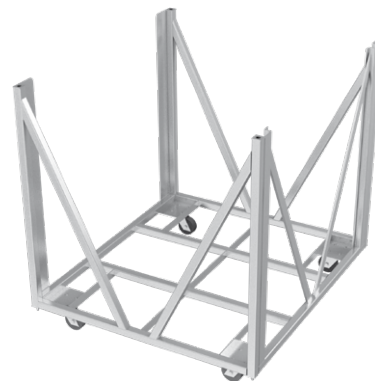

BR1-BOX-B / BR-BOXV

Barrier dolly for base & gate
 126 x 120 x 134 cm
 (49.61 x 47.24 x 52.76 in)
 75 kg (165 lbs) /
 80 kg (176 lbs)

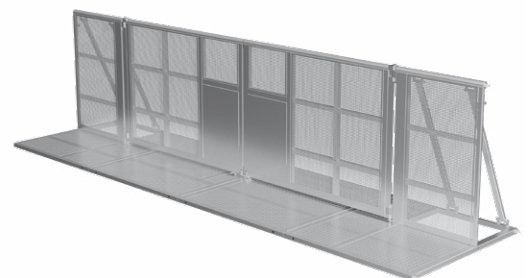

BR1-G3,0

Gate clearance 3 m (9.84 ft)
 4.6 x 1.25 m
 (15.09 x 4.10 ft)
 101 kg (222.67 lbs)



TRUCK RAMPS

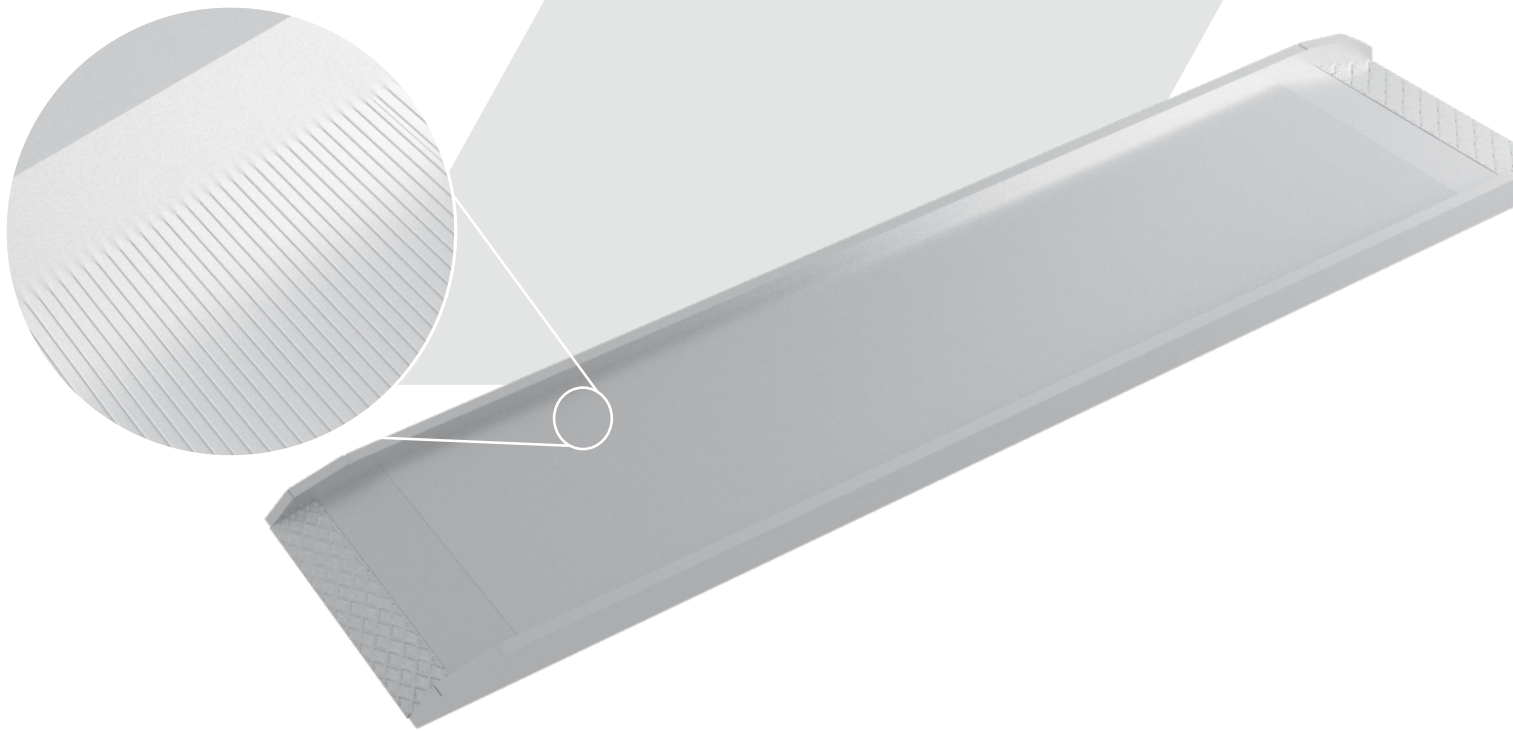

TAF offers a range of aluminium loading ramps for trucks, vans, and other vehicles. We produce ramps in the following widths - 80 cm (31.5 in), 100 cm (39.5 in), and 110 cm (43.3 in). The dimensions of the truck ramps, width and length, can be adjusted on request so you get exactly what you need. TAF truck ramps are made of aluminium profiles that are specially designed to handle high loads.



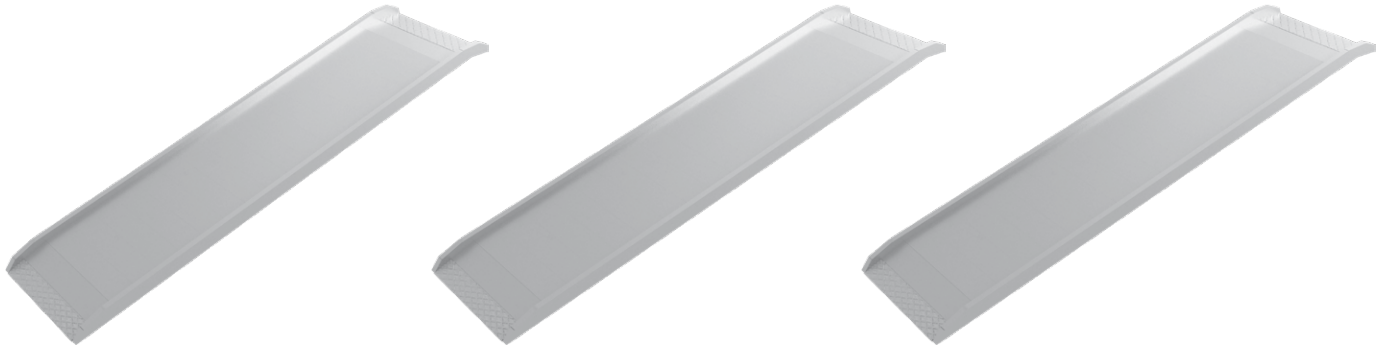

TR-2-80 80 x 200 cm (2.63 x 6.56 ft) 38.3 kg (84.43 lbs)	TR-2-100 100 x 200 cm (3.28 x 6.56 ft) 44.2 kg (97.44 lbs)	TR-2-110 110 x 200 cm (3.61 x 6.56 ft) 47 kg (103.62 lbs)
TR-3-80 80 x 300 cm (2.63 x 9.84 ft) 56.4 kg (124.34 lbs)	TR-3-100 100 x 300 cm (3.28 x 9.84 ft) 65 kg (143.30 lbs)	TR-3-110 110 x 300 cm (3.61 x 9.84 ft) 69.4 kg (152.98 lbs)
TR-4-80 80 x 400 cm (2.63 x 13.12 ft) 74.2 kg (163.61 lbs)	TR-4-100 100 x 400 cm (3.28 x 13.12 ft) 85.5 kg (188.52 lbs)	TR-4-110 110 x 400 cm (3.61 x 13.12 ft) 91.2 kg (201.14 lbs)
TR-5-80 80 x 500 cm (2.63 x 16.40 ft) 91.9 kg (202.58 lbs)	TR-5-100 100 x 500 cm (3.28 x 16.41 ft) 105.8 kg (233.26 lbs)	TR-5-110 110 x 500 cm (3.61 x 16.41 ft) 113 kg (249.12 lbs)

LOADING CHART

		Couple of Forces, ΣF [kN]			Single Force F [kN]		
		80	100	110	80	100	110
2 m	EL	8.46	5.95	5.17	4.76	3.81	3.46
3 m	EL	8.46	5.95	5.17	4.76	3.81	3.46
4 m	EL	8.46	5.95	5.17	4.76	3.81	3.46
5 m	EL	7.57*	5.95	5.17	4.75*	3.81	3.46

EL= Elastic Load Capacities

* decisive load is beam capacity (not grid)

APPLICATION CHART

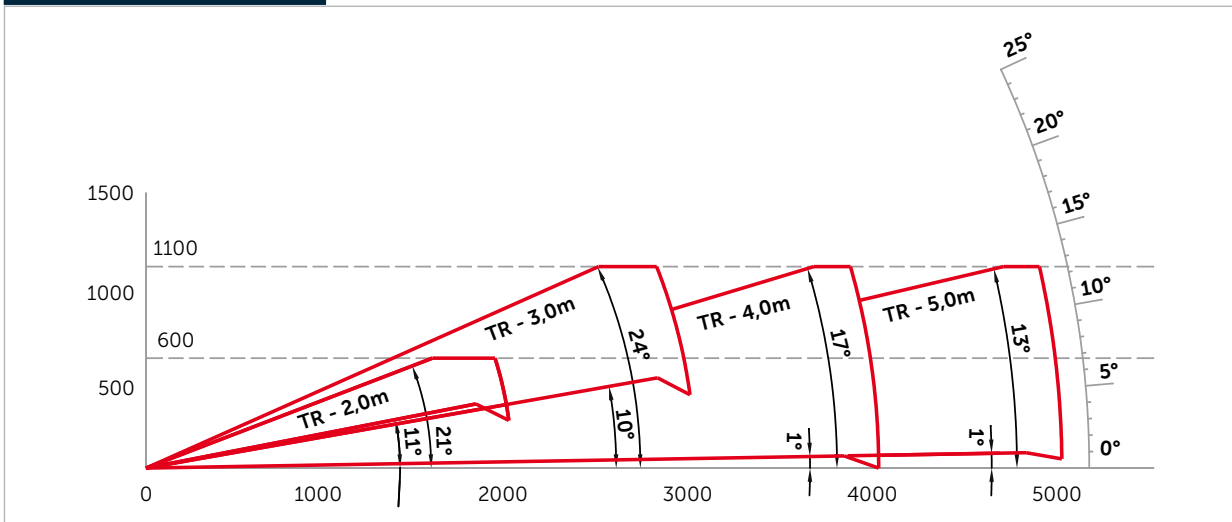

SPECS SUMMARY

Quicklock Line FT14

SPECIFICATIONS

TUBES	20 x 2 mm (0.79 x 0.08 in)
BRACES	6 mm (0.24 in)
ALLOY	EN AW-6082 T6

LOADING TABLES		2 m	4 m	6 m	8 m	10 m
UDL [kg/m]		220	61	29	14	9
Deflection [mm]		12.1	41.5	91.7	155.7	261.1
CPL [kg]		147	93	69	52	44
Deflection [mm]		6.4	25.4	60.5	118.5	196.5
		6.56 ft	13.12 ft	19.68 ft	26.24 ft	32.81 ft
UDL [lbs/ft]		147.9	41	19.5	9.4	6
Deflection [in]		0.5	1.6	3.6	6.1	10.3
CPL [lbs]		324.1	205.1	152.1	114.7	97
Deflection [in]		0.3	1	2.4	4.7	7.7

Quicklock Line FT21

SPECIFICATIONS

TUBES	35 x 2 mm (1.38 x 0.08 in)
ALLOY	EN AW-6060 T66

LOADING TABLES		1 m	2 m	3 m	4 m
UDL [kg/m]		113	28	13	7
Deflection [mm]		7.4	29.7	66.7	118.6
CPL [kg]		56	28	19	14
Deflection [mm]		5.9	23.7	53.4	94.9
		3.28 ft	6.56 ft	9.84 ft	13.12 ft
UDL [lbs/ft]		75.9	18.8	8.7	4.7
Deflection [in]		0.3	1.2	2.6	4.7
CPL [lbs]		123.5	61.7	41.9	30.9
Deflection [in]		0.2	0.9	2.1	3.7

Quicklock Line FT22

SPECIFICATIONS

TUBES	35 x 2 mm (1.38 x 0.08 in)
BRACES	8 mm (0.31 in)
ALLOY	EN AW-6060 T66

LOADING TABLES		2 m	3 m	4 m	6 m	8 m	10 m
UDL [kg/m]		101	67	48	21	11	7
Deflection [mm]		0.9	2.9	6.6	15.5	27.7	43.6
CPL [kg]		196	129	96	63	44	33
Deflection [mm]		1.3	3	5.4	12.6	22.9	36.7
		6.56 ft	9.84 ft	13.12 ft	19.68 ft	26.24 ft	32.81 ft
UDL [lbs/ft]		67.9	45	32.3	14.1	7.4	4.7
Deflection [in]		0.04	0.1	0.3	0.6	1.1	1.7
CPL [lbs]		432.2	284.4	211.7	138.9	97	72.8
Deflection [in]		0.1	0.1	0.2	0.5	0.9	1.4

Quicklock Line FT23

SPECIFICATIONS

TUBES	35 x 2 mm (1.38 x 0.08 in)
BRACES	8 mm (0.31 in)
ALLOY	EN AW-6060 T66

LOADING TABLES		2 m	3 m	4 m	6 m	8 m	10 m
UDL [kg/m]		175	114	64	27	14	8
Deflection [mm]		1.5	4.9	8.9	20.1	36	56.8
CPL [kg]		262	171	127	81	56	41
Deflection [mm]		1.8	4	7.2	16.5	30	48.3
		6.56 ft	9.84 ft	13.12 ft	19.68 ft	26.24 ft	32.81 ft
UDL [lbs/ft]		117.6	76.6	43	18.1	9.4	5.4
Deflection [in]		0.1	0.2	0.4	0.8	1.4	2.2
CPL [lbs]		577.7	377.1	280	178.6	123.5	90.4
Deflection [in]		0.1	0.2	0.3	0.6	1.2	1.9

Quicklock Line FT24

SPECIFICATIONS

TUBES	35 x 2 mm (1.38 x 0.08 in)
BRACES	8 mm (0.31 in)
ALLOY	EN AW-6060 T6

LOADING TABLES		2 m	3 m	4 m	6 m	8 m	10 m
UDL [kg/m]		202	134	100	65	35	21
Deflection [mm]		0.9	2.9	6.9	23.1	41.3	64.8
CPL [kg]		405	354	286	195	141	107
Deflection [mm]		1.4	4.1	7.9	18.7	33.7	53.6
		6.56 ft	9.84 ft	13.12 ft	19.68 ft	26.24 ft	32.81 ft
UDL [lbs/ft]		135.8	90.1	67.2	43.7	23.5	14.1
Deflection [in]		0	0.1	0.3	0.9	1.6	2.6
CPL [lbs]		893	780.6	630.6	430	310.9	235.9
Deflection [in]		0.1	0.2	0.3	0.7	1.3	2.1

Loading tables are valid for static loads and spans with two supporting points. Spans must be supported at each end. Contact structural engineer if there are more supporting points applied or dynamic and wind loads involved.

Quicklock Line FT31

SPECIFICATIONS

TUBES	50 x 2 mm (1.97 x 0.08 in)
ALLOY	EN AW-6082 T6

LOADING TABLES		1 m	2 m	3 m	4 m
UDL [kg/m]		438	109	49	27
Deflection [mm]		9.4	37.4	84.2	149.7
CPL [kg]		219	109	73	55
Deflection [mm]		7.5	29.9	67.4	119.8
		3.28 ft	6.56 ft	9.84 ft	13.12 ft
UDL [lbs/ft]		294.4	73.3	32.9	18.1
Deflection [in]		0.4	1.5	3.3	5.9
CPL [lbs]		482.9	240.3	161	121.3
Deflection [in]		0.3	1.2	2.7	4.7

Quicklock Line FT32

SPECIFICATIONS

TUBES	50 x 2 mm (1.97 x 0.08 in)
BRACES	20 x 2 mm (0.79 x 0.08 in)
ALLOY	EN AW-6082 T6

LOADING TABLES		2 m	4 m	6 m	8 m	10 m	12 m
UDL [kg/m]		673	166	76	43	27	18
Deflection [mm]		2.3	9.3	21.9	39.8	63.7	94
CPL [kg]		673	333	228	170	135	110
Deflection [mm]		1.9	7.4	17.6	32.3	52.5	77.7
		6.56 ft	13.12 ft	19.68 ft	26.24 ft	32.81 ft	39.37 ft
UDL [lbs/ft]		452.3	111.6	51.1	28.9	18.1	12.1
Deflection [in]		0.1	0.4	0.9	1.6	2.5	3.7
CPL [lbs]		1484	734.3	502.7	374.9	297.7	242.6
Deflection [in]		0.1	0.3	0.7	1.3	2.1	3.1

Quicklock Line HT32

SPECIFICATIONS

TUBES	50 x 3 mm (1.97 x 0.12 in)
BRACES	20 x 2 mm (0.79 x 0.08 in)
ALLOY	EN AW-6082 T6

LOADING TABLES		2 m	4 m	6 m	8 m	10 m	12 m
UDL [kg/m]		710	254	115	64	40	27
Deflection [mm]		1.7	9.6	22.3	40.4	64.2	94.1
CPL [kg]		1027	508	344	256	202	165
Deflection [mm]		1.9	7.7	18	32.8	52.5	77.5
		6.56 ft	13.12 ft	19.68 ft	26.24 ft	32.81 ft	39.37 ft
UDL [lbs/ft]		477.2	170.7	77.3	43	26.9	18.1
Deflection [in]		0.1	0.4	0.9	1.6	2.5	3.7
CPL [lbs]		2264.5	1120.1	758.5	564.5	445.4	363.8
Deflection [in]		0.1	0.3	0.7	1.3	2.1	3.1

Quicklock Line FT33

SPECIFICATIONS

TUBES	50 x 2 mm (1.97 x 0.08 in)
BRACES	20 x 2 mm (0.79 x 0.08 in)
ALLOY	EN AW-6082 T6

LOADING TABLES		2 m	4 m	6 m	8 m	10 m	12 m
UDL [kg/m]		761	206	92	51	31	20
Deflection [mm]		2.6	11.5	26.8	48.8	75.2	105.6
CPL [kg]		761	412	277	206	154	117
Deflection [mm]		2.1	9.3	21.7	39.8	62	88.3
		6.56 ft	13.12 ft	19.68 ft	26.24 ft	32.81 ft	39.37 ft
UDL [lbs/ft]		511.4	138.4	61.8	34.3	20.8	13.4
Deflection [in]		0.1	0.5	1.1	1.9	3	4.2
CPL [lbs]		1678	908.5	610.8	454.2	339.6	258
Deflection [in]		0.1	0.4	0.9	1.6	2.4	3.5

Quicklock Line HT33

SPECIFICATIONS

TUBES	50 x 3 mm (1.97 x 0.12 in)
BRACES	20 x 2 mm (0.79 x 0.08 in)
ALLOY	EN AW-6082 T6

LOADING TABLES		2 m	4 m	6 m	8 m	10 m	12 m
UDL [kg/m]		1231	338	150	81	50	32
Deflection [mm]		2.9	12.8	29.4	51.7	80.6	112.7
CPL [kg]		1321	675	450	324	249	190
Deflection [mm]		2.5	10.3	23.7	42.1	66.1	93.5
		6.56 ft	13.12 ft	19.68 ft	26.24 ft	32.81 ft	39.37 ft
UDL [lbs/ft]		827.3	227.2	100.8	54.4	33.6	21.5
Deflection [in]		0.1	0.5	1.2	2	3.2	4.4
CPL [lbs]		2912.8	1488.4	992.3	714.4	549	419
Deflection [in]		0.1	0.4	0.9	1.7	2.6	3.7

Loading tables are valid for static loads and spans with two supporting points. Spans must be supported at each end. Contact structural engineer if there are more supporting points applied or dynamic and wind loads involved.

SPECS SUMMARY

Quicklock Line FT34

SPECIFICATIONS

TUBES	50 x 2 mm (1.97 x 0.08 in)
BRACES	20 x 2 mm (0.79 x 0.08 in)
ALLOY	EN AW-6082 T6

LOADING TABLES

		2 m	3 m	4 m	6 m	8 m	10 m	12 m	14 m	16 m	18 m	20 m
UDL [kg/m]		1422	946	566	250	139	86	58	39	27	16	6
Deflection [mm]		2.4	8.3	15.7	35.5	63.3	98.6	140.4	185	227.6	248.8	195.9
CPL [kg]		2261	1509	1131	750	554	432	345	275	214	148	58
Deflection [mm]		3.1	7	12.6	28.5	51.1	80.1	114.8	152.7	190	211.7	176.1
TPL [kg]		1422	1132	849	562	416	324	259	206	161	111	43
Deflection [mm]		3.3	9	16	36.2	64.6	100.7	143.2	188.6	231.8	252.9	198.1
QPL [kg]		948	755	566	375	277	216	173	138	107	74	29
Deflection [mm]		3.1	8.3	14.9	33.7	60.2	94	134	176.9	218.2	239.5	190.9
FPL [kg]		711	629	471	312	231	180	144	115	89	62	24
Deflection		3	8.9	15.9	36.1	64.3	100.2	142.6	187.8	230.9	252	197.6
		6.56 ft	9.84 ft	13.12 ft	19.69 ft	26.25 ft	32.81 ft	39.37 ft	45.93 ft	52.49 ft	59.06 ft	65.62 ft
UDL [lbs/ft]		955.54	635.68	380.33	167.99	93.40	57.79	38.97	26.21	18.14	10.75	4.03
Deflection [in]		0.09	0.33	0.62	1.40	2.49	3.88	5.53	7.28	8.96	9.80	7.71
CPL [lbs]		4984.65	3326.78	2493.43	1653.47	1221.36	952.40	760.59	606.27	471.79	326.28	127.87
Deflection [in]		0.12	0.28	0.50	1.12	2.01	3.15	4.52	6.01	7.48	8.33	6.93
TPL [lbs]		3134.97	2495.63	1871.72	1239.00	917.12	714.30	571.00	454.15	354.94	244.71	94.80
Deflection [in]		0.13	0.35	0.63	1.43	2.54	3.96	5.64	7.43	9.13	9.96	7.80
QPL [lbs]		2089.98	1664.49	1247.82	826.73	610.68	476.20	381.40	304.24	235.89	163.14	63.93
Deflection [in]		0.12	0.33	0.59	1.33	2.37	3.70	5.28	6.96	8.59	9.43	7.52
FPL [lbs]		1567.49	1386.71	1038.38	687.84	509.27	396.83	317.47	253.53	196.21	136.69	52.91
Deflection [in]		0.12	0.35	0.63	1.42	2.53	3.94	5.61	7.39	9.09	9.92	7.78

Quicklock Line HT34

SPECIFICATIONS

TUBES	50 x 3 mm (1.97 x 0.12 in)
BRACES	20 x 2 mm (0.79 x 0.08 in)
ALLOY	EN AW-6082 T6

LOADING TABLES

		2 m	3 m	4 m	6 m	8 m	10 m	12 m	14 m	16 m	18 m	20 m
UDL [kg/m]		1420	944	707	359	199	125	83	58	39	25	9
Deflection [mm]		1.7	5.6	13.3	34.6	61.7	96.2	137.1	182.7	224.1	246	196.9
CPL [kg]		2847	2160	1621	1076	797	623	500	405	316	223	95
Deflection [mm]		2.7	6.8	12.2	27.8	49.8	78.1	112	150.3	186.3	208.2	174.8
TPL [kg]		1420	1417	1215	807	598	467	375	304	237	167	71
Deflection [mm]		2.3	7.6	15.6	35.3	63	98.3	139.9	186.3	228.3	250.2	199.3
QPL [kg]		947	944	810	538	398	312	250	202	158	111	47
Deflection [mm]		2.1	7.1	14.5	32.9	58.7	91.7	130.8	174.6	214.6	236.6	191.3
FPL [kg]		710	708	675	448	332	260	208	169	132	93	39
Deflection		2	6.9	15.5	35.2	62.7	97.8	139.3	185.5	227.3	249.3	198.8
		6.56 ft	9.84 ft	13.12 ft	19.69 ft	26.25 ft	32.81 ft	39.37 ft	45.93 ft	52.49 ft	59.06 ft	65.62 ft
UDL [lbs/ft]		954.20	634.34	475.08	241.24	133.72	84.00	55.77	38.97	26.21	16.80	6.05
Deflection [in]		0.07	0.22	0.52	1.36	2.43	3.79	5.40	7.19	8.82	9.69	7.75
CPL [lbs]		6276.56	4761.98	3573.69	2372.17	1757.08	1373.48	1102.31	892.87	696.66	491.63	209.44
Deflection [in]		0.11	0.27	0.48	1.09	1.96	3.07	4.41	5.92	7.33	8.20	6.88
TPL [lbs]		3130.56	3123.95	2678.62	1779.13	1318.36	1029.56	826.73	670.21	522.50	368.17	156.53
Deflection [in]		0.09	0.30	0.61	1.39	2.48	3.87	5.51	7.33	8.99	9.85	7.85
QPL [lbs]		2087.78	2081.16	1785.74	1186.09	877.44	687.84	551.16	445.33	348.33	244.71	103.62
Deflection [in]		0.08	0.28	0.57	1.30	2.31	3.61	5.15	6.87	8.45	9.31	7.53
FPL [lbs]		1565.28	1560.87	1488.12	987.67	731.93	573.20	458.56	372.58	291.01	205.03	85.98
Deflection [in]		0.08	0.27	0.61	1.39	2.47	3.85	5.48	7.30	8.95	9.81	7.83

Loading tables are valid for static loads and spans with two supporting points. Spans must be supported at each end. Contact structural engineer if there are more supporting points applied or dynamic and wind loads involved.

Quicklock Line FT42

SPECIFICATIONS

TUBES	50 x 2 mm (1.97 x 0.08 in)
BRACES	25 x 3 mm (0.98 x 0.12 in)
ALLOY	EN AW-6082 T6

LOADING TABLES

		2 m	4 m	6 m	8 m	10 m	12 m	14 m	16 m
UDL [kg/m]		756	243	109	61	39	27	19	14
Deflection [mm]		1.2	6.4	14.7	26.7	42.7	63	87.8	115.3
CPL [kg]		756	486	327	245	195	161	135	113
Deflection [mm]		1	5.1	11.8	21.6	34.8	51.8	72.9	96.7
		6.56 ft	13.12 ft	19.68 ft	26.24 ft	32.81 ft	39.37 ft	45.93 ft	52.49 ft
UDL [lbs/ft]		508.1	163.3	73.3	41	26.2	18.1	12.8	9.4
Deflection [in]		0.05	0.3	0.6	1.1	1.7	2.5	3.5	4.5
CPL [lbs]		1667	1071.6	721	540.2	430	355	297.7	249.2
Deflection [in]		0.04	0.2	0.5	0.9	1.4	2	2.9	3.8

Quicklock Line HT42

SPECIFICATIONS

TUBES	50 x 3 mm (1.97 x 0.12 in)
BRACES	25 x 3 mm (0.98 x 0.12 in)
ALLOY	EN AW-6082 T6

LOADING TABLES

		2 m	4 m	6 m	8 m	10 m	12 m	14 m	16 m
UDL [kg/m]		1042	332	153	87	57	40	29	21
Deflection [mm]		1.1	5.9	14	25.7	42.1	63.5	87.9	115.2
CPL [kg]		1042	664	459	349	286	243	204	172
Deflection [mm]		0.9	4.7	11.3	20.8	34.3	52	72.5	95.9
		6.56 ft	13.12 ft	19.68 ft	26.24 ft	32.81 ft	39.37 ft	45.93 ft	52.49 ft
UDL [lbs/ft]		700.3	223.1	102.8	58.5	38.3	26.9	19.5	14.1
Deflection [in]		0.04	0.2	0.6	1	1.7	2.5	3.5	4.5
CPL [lbs]		2297.6	1464.1	1012.1	769.5	630.6	535.8	449.8	379.3
Deflection [in]		0.04	0.2	0.4	0.8	1.4	2	2.9	3.8

Quicklock Line FT43

SPECIFICATIONS

TUBES	50 x 2 mm (1.97 x 0.08 in)
BRACES	25 x 3 mm (0.98 x 0.12 in)
ALLOY	EN AW-6082 T6

LOADING TABLES

		2 m	4 m	6 m	8 m	10 m	12 m	14 m	16 m
UDL [kg/m]		779	272	124	70	45	31	21	15
Deflection [mm]		1.3	7.2	16.9	31.3	50.9	75.6	100.8	133.3
CPL [kg]		779	544	371	282	225	184	144	121
Deflection [mm]		1	5.8	13.6	25.5	41.8	62.8	84.9	116.1
		6.56 ft	13.12 ft	19.68 ft	26.24 ft	32.81 ft	39.37 ft	45.93 ft	52.49 ft
UDL [lbs/ft]		523.5	182.8	83.3	47	30.2	20.8	14.1	10.1
Deflection [in]		0.1	0.3	0.7	1.2	2	3	4	5.2
CPL [lbs]		1717.7	1199.5	818.1	621.8	496.1	405.7	317.5	266.8
Deflection [in]		0.04	0.2	0.5	1	1.6	2.5	3.3	4.6

Loading tables are valid for static loads and spans with two supporting points. Spans must be supported at each end. Contact structural engineer if there are more supporting points applied or dynamic and wind loads involved.

The listed loads are verified for simply supported beam. The truss needs to be secured against horizontal movement every 1 m for the loading tables to be valid.

SPECS SUMMARY

Quicklock Line HT43

SPECIFICATIONS

TUBES	50 x 3 mm (1.97 x 0.12 in)
BRACES	25 x 3 mm (0.98 x 0.12 in)
ALLOY	EN AW-6082 T6

LOADING TABLES

		2 m	4 m	6 m	8 m	10 m	12 m	14 m	16 m
UDL [kg/m]		1412	457	212	119	75	51	34	25
Deflection [mm]		1.6	8.1	19.4	35.3	56.2	81.9	108.8	140.9
CPL [kg]		1412	913	636	475	375	304	241	207
Deflection [mm]		1.2	6.5	15.7	28.6	45.9	67.5	90.7	123.7
		6.56 ft	13.12 ft	19.68 ft	26.24 ft	32.81 ft	39.37 ft	45.93 ft	52.49 ft
UDL [lbs/ft]		948.9	307.1	142.5	80	50.4	34.3	22.8	16.8
Deflection [in]		0.1	0.3	0.8	1.4	2.2	3.2	4.3	5.5
CPL [lbs]		3113.5	2013.2	1402.4	1047.4	826.9	670.3	531.4	456.4
Deflection [in]		0.05	0.3	0.6	1.1	1.8	2.7	3.6	4.9

Quicklock Line FT44

SPECIFICATIONS

TUBES	50 x 2 mm (1.97 x 0.08 in)
BRACES	25 x 3 mm (0.98 x 0.12 in)
ALLOY	EN AW-6082 T6

LOADING TABLES

		2 m	4 m	6 m	8 m	10 m	12 m	14 m	16 m
UDL [kg/m]		1805	595	274	163	106	73	52	38
Deflection [mm]		1.5	7.8	18.4	35.2	57.3	83.5	114.9	151.1
CPL [kg]		1805	1190	823	653	532	436	364	304
Deflection [mm]		1.2	6.2	14.8	28.5	46.6	68.4	94.7	124.5
		6.56 ft	13.12 ft	19.68 ft	26.24 ft	32.81 ft	39.37 ft	45.93 ft	52.49 ft
UDL [lbs/ft]		1213.1	399.9	184.1	109.5	71.2	49.1	34.9	25.5
Deflection [in]		0.1	0.3	0.7	1.4	2.3	3.3	4.5	5.9
CPL [lbs]		3980	2624	1814.7	1439.9	1173.1	961.4	802.6	670.3
Deflection [in]		0.05	0.2	0.6	1.1	1.8	2.7	3.7	4.9

Quicklock Line HT44

SPECIFICATIONS

TUBES	50 x 3 mm (1.97 x 0.12 in)
BRACES	25 x 3 mm (0.98 x 0.12 in)
ALLOY	EN AW-6082 T6

LOADING TABLES

		2 m	4 m	6 m	8 m	10 m	12 m	14 m	16 m
UDL [kg/m]		2327	901	417	243	162	112	82	61
Deflection [mm]		1.3	8	18.9	35.4	58.8	86.5	119.8	158.7
CPL [kg]		3267	1803	1252	971	811	675	573	477
Deflection [mm]		1.4	6.4	15.2	28.5	47.6	70.5	98.3	127.8
		6.56 ft	13.12 ft	19.68 ft	26.24 ft	32.81 ft	39.37 ft	45.93 ft	52.49 ft
UDL [lbs/ft]		1563.9	605.5	280.2	163.3	108.9	75.3	55.1	41
Deflection [in]		0.1	0.3	0.7	1.4	2.3	3.4	4.7	6.2
CPL [lbs]		7203.7	3975.6	2760.7	2141.1	1788.3	1488.4	1263.5	1051.8
Deflection [in]		0.1	0.3	0.6	1.1	1.9	2.8	3.9	5

Loading tables are valid for static loads and spans with two supporting points. Spans must be supported at each end. Contact structural engineer if there are more supporting points applied or dynamic and wind loads involved.

Quicklock Line **FTR4030**

SPECIFICATIONS

TUBES	50 x 3 mm (1.97 x 0.12 in)
BRACES	25 x 3 mm (0.98 x 0.12 in)
ALLOY	EN AW-6082 T6

LOADING TABLES

		6 m	8 m	10 m	12 m	14 m	16 m	18 m
UDL [kg/m]		464	261	167	115	85	63	47
Deflection [mm]		20.9	37.5	59.2	85.8	119.3	154.1	190
CPL [kg]		1392	1045	833	688	592	501	421
Deflection [mm]		16.8	30.2	47.7	69.5	97	126	156.3
		19.68 ft	26.24 ft	32.81 ft	39.37 ft	45.93 ft	52.49 ft	59.05 ft
UDL [lbs/ft]		311.8	175.4	112.2	77.3	57.1	42.3	31.6
Deflection [in]		0.8	1.5	2.3	3.4	4.7	6.1	7.5
CPL [lbs]		3069.4	2304.2	1836.8	1517	1305.4	1104.7	928.3
Deflection [in]		0.7	1.2	1.9	2.7	3.8	5	6.2

Quicklock Line **TT34**

SPECIFICATIONS

TUBES	50 x 4 mm (1.97 x 0.16 in)
BRACES	20 x 2 mm (0.79 x 0.08 in)
ALLOY	EN AW-6082 T6

LOADING TABLES

		2 m	3 m	4 m	6 m	8 m	10 m	12 m	14 m	16 m	18 m	20 m
UDL [kg/m]		1418	943	705	450	251	157	107	74	51	33	13
Deflection [mm]		1.3	4.3	10.2	33.3	59.4	92.8	134	177.9	219.8	243.9	198.4
CPL [kg]		2845	2744	2060	1351	1002	785	639	517	408	293	131
Deflection [mm]		2	6.7	11.9	26.7	47.9	75.2	109.3	146.2	182.5	205.8	175
TPL [kg]		1418	1414	1410	1013	752	589	479	387	306	219	98
Deflection [mm]		1.7	5.9	13.9	34	60.7	94.7	136.7	181.4	223.9	248.2	201
QPL [kg]		946	943	940	675	501	393	320	258	204	146	66
Deflection [mm]		1.6	5.4	12.9	31.6	56.5	88.4	127.8	169.9	210.5	234.4	192.6
FPL [kg]		709	707	705	563	418	327	266	215	170	122	55
Deflection		1.6	5.2	12.4	33.8	60.4	94.3	136.1	180.6	223	247.2	200.4
		6.56 ft	9.84 ft	13.12 ft	19.69 ft	26.25 ft	32.81 ft	39.37 ft	45.93 ft	52.49 ft	59.06 ft	65.62 ft
UDL [lbs/ft]		952.85	633.67	473.74	302.39	168.66	105.50	71.90	49.73	34.27	22.17	8.74
Deflection [in]		0.05	0.17	0.40	1.31	2.34	3.65	5.28	7.00	8.65	9.60	7.81
CPL [lbs]		6272.15	6049.48	4541.52	2978.45	2209.03	1730.63	1408.75	1139.79	899.49	645.95	288.81
Deflection [in]		0.08	0.26	0.47	1.05	1.89	2.96	4.30	5.76	7.19	8.10	6.89
TPL [lbs]		3126.15	3117.34	3108.52	2233.28	1657.88	1298.52	1056.01	853.19	674.61	482.81	216.05
Deflection [in]		0.07	0.23	0.55	1.34	2.39	3.73	5.38	7.14	8.81	9.77	7.91
QPL [lbs]		2085.57	2078.96	2072.35	1488.12	1104.52	866.42	705.48	568.79	449.74	321.87	145.51
Deflection [in]		0.06	0.21	0.51	1.24	2.22	3.48	5.03	6.69	8.29	9.23	7.58
FPL [lbs]		1563.08	1558.67	1554.26	1241.20	921.53	720.91	586.43	473.99	374.79	268.96	121.25
Deflection [in]		0.06	0.20	0.49	1.33	2.38	3.71	5.36	7.11	8.78	9.73	7.89

Loading tables are valid for static loads and spans with two supporting points. Spans must be supported at each end. Contact structural engineer if there are more supporting points applied or dynamic and wind loads involved.

SPECS SUMMARY

Quicklock Line TT44

SPECIFICATIONS

TUBES	50 x 4 mm (1.97 x 0.16 in)
BRACES	25 x 3 mm (0.98 x 0.12 in)
ALLOY	EN AW-6082 T6

LOADING TABLES

		2 m	4 m	6 m	8 m	10 m	12 m	14 m	16 m	18 m	20 m
UDL [kg/m]		2126	1057	700	390	245	166	119	88	66	50
Deflection [mm]		0.9	7.2	24.3	43.5	68.1	98.3	134.2	175.8	221.8	267.2
CPL [kg]		4253	3197	2111	1561	1226	999	833	705	596	496
Deflection [mm]		1.4	8.7	19.6	35.1	55.2	80.2	110.1	145.4	184.6	225.5
TPL [kg]		2137	2136	1583	1171	920	749	625	529	447	372
Deflection [mm]		1.2	9.9	25	44.4	69.5	100.3	136.8	179.2	225.1	271.8
QPL [kg]		1424	1423	1055	781	613	499	416	353	298	248
Deflection [mm]		1.1	9.2	23.2	41.4	64.9	93.8	128.1	168.2	212	256.7
		6.56 ft	13.12 ft	19.69 ft	26.25 ft	32.81 ft	39.37 ft	45.93 ft	52.49 ft	59.06 ft	65.62 ft
UDL [lbs/ft]		1428.61	710.27	470.38	262.07	164.63	111.55	79.96	59.13	44.35	33.60
Deflection [in]		0.04	0.28	0.96	1.71	2.68	3.87	5.28	6.92	8.73	10.52
CPL [lbs]		9376.26	7048.18	4653.96	3441.42	2702.87	2202.42	1836.45	1554.26	1313.96	1093.49
Deflection [in]		0.06	0.34	0.77	1.38	2.17	3.16	4.33	5.72	7.27	8.88
TPL [lbs]		4711.28	4709.07	3489.92	2581.61	2028.25	1651.26	1377.89	1166.25	985.47	820.12
Deflection [in]		0.05	0.39	0.98	1.75	2.74	3.95	5.39	7.06	8.86	10.70
QPL [lbs]		3139.38	3137.18	2325.88	1721.81	1351.43	1100.11	917.12	778.23	656.98	546.75
Deflection [in]		0.04	0.36	0.91	1.63	2.56	3.69	5.04	6.62	8.35	10.11

Quicklock Line TC35

SPECIFICATIONS

TUBES	50 x 4 mm (1.97 x 0.16 in)
BRACES	20 x 2 mm (0.79 x 0.08 in)
PLATES	8 mm (0.31 in)
ALLOY	EN AW-6082 T6

LOADING TABLES - COMPLETE TRUSS

		4 m	5 m	6 m	7 m	8 m	10 m	12 m	14 m	16 m	18 m	20 m
UDL [kg/m]		746	594	456	331	251	155	104	73	53	39	29
Deflection [mm]		10	20	33	45	59	92	133	181	238	303	377
CPL [kg]		2085	1656	1368	1160	1002	777	623	509	420	303	287
Deflection [mm]		12	18	26	36	47	75	109	151	201	259	327
TPL [kg]		1412	1242	1026	870	752	583	467	382	315	261	216
Deflection [mm]		14	23	33	45	58	87	121	157	193	228	258
QPL [kg]		941	828	684	580	501	389	312	254	210	174	144
Deflection [mm]		13	22	31	41	53	81	112	146	179	211	240
FPL [kg]		706	684	570	483	418	324	260	212	175	145	120
Deflection [mm]		12	23	33	44	57	86	119	154	190	224	254
		13.12 ft	16.40 ft	19.69 ft	22.97 ft	26.25 ft	32.81 ft	39.37 ft	45.93 ft	52.49 ft	59.06 ft	65.62 ft
UDL [lbs/ft]		501.29	399.15	306.42	222.42	168.66	104.16	69.88	49.05	35.61	26.21	19.49
Deflection [in]		0.39	0.79	1.30	1.77	2.32	3.62	5.24	7.13	9.37	11.93	14.84
CPL [lbs]		4596.64	3650.86	3015.92	2557.36	2209.03	1712.99	1373.48	1122.15	925.94	668.00	632.73
Deflection [in]		0.47	0.71	1.02	1.42	1.85	2.95	4.29	5.94	7.91	10.20	12.87
TPL [lbs]		3112.93	2738.14	2261.94	1918.02	1657.88	1285.29	1029.56	842.17	694.46	575.41	476.20
Deflection [in]		0.55	0.91	1.30	1.77	2.28	3.43	4.76	6.18	7.60	8.98	10.16
QPL [lbs]		2074.55	1825.43	1507.96	1278.68	1104.52	857.60	687.84	559.97	462.97	383.60	317.47
Deflection [in]		0.51	0.87	1.22	1.61	2.09	3.19	4.41	5.75	7.05	8.31	9.45
FPL [lbs]		1556.46	1507.96	1256.63	1064.83	921.53	714.30	573.20	467.38	385.81	319.67	264.55
Deflection [in]		0.47	0.91	1.30	1.73	2.24	3.39	4.69	6.06	7.48	8.82	10.00

Loading tables are valid for static loads and spans with two supporting points. Spans must be supported at each end. Contact structural engineer if there are more supporting points applied or dynamic and wind loads involved.

LOADING TABLES - CENTRAL BOTTOM TUBE

		4 m	5 m	6 m	7 m	8 m	10 m	12 m	14 m	16 m	18 m	20 m
UDL [kg/m]		746	594	456	331	251	155	104	73	53	39	29
Deflection [mm]		10	20	33	45	59	92	133	181	238	303	377
CPL [kg]		800	800	800	800	800	777	623	509	420	348	287
Deflection [mm]		5	9	16	26	39	75	109	151	201	259	327
TPL [kg]		800	800	800	800	752	583	467	382	315	261	216
Deflection [mm]		8	15	26	41	58	87	121	157	193	228	258
QPL [kg]		800	800	684	580	501	389	312	254	210	174	144
Deflection [mm]		11	21	31	41	53	81	112	146	179	211	240
FPL [kg]		706	684	570	483	418	324	260	212	175	145	120
Deflection [mm]		12	23	33	44	57	86	119	154	190	224	254
		13.12 ft	16.40 ft	19.69 ft	22.97 ft	26.25 ft	32.81 ft	39.37 ft	45.93 ft	52.49 ft	59.06 ft	65.62 ft
UDL [lbs/ft]		501.29	399.15	306.42	222.42	168.66	104.16	69.88	49.05	35.61	26.21	19.49
Deflection [in]		0.39	0.79	1.30	1.77	2.32	3.62	5.24	7.13	9.37	11.93	14.84
CPL [lbs]		1763.70	1763.70	1763.70	1763.70	1763.70	1712.99	1373.48	1122.15	925.94	767.21	632.73
Deflection [in]		0.20	0.35	0.63	1.02	1.54	2.95	4.29	5.94	7.91	10.20	12.87
TPL [lbs]		1763.70	1763.70	1763.70	1763.70	1657.88	1285.29	1029.56	842.17	694.46	575.41	476.20
Deflection [in]		0.31	0.59	1.02	1.61	2.28	3.43	4.76	6.18	7.60	8.98	10.16
QPL [lbs]		1763.70	1763.70	1507.96	1278.68	1104.52	857.60	687.84	559.97	462.97	383.60	317.47
Deflection [in]		0.43	0.83	1.22	1.61	2.09	3.19	4.41	5.75	7.05	8.31	9.45
FPL [lbs]		1556.46	1507.96	1256.63	1064.83	921.53	714.30	573.20	467.38	385.81	319.67	264.55
Deflection [in]		0.47	0.91	1.30	1.73	2.24	3.39	4.69	6.06	7.48	8.82	10.00

Quicklock Line TC45
SPECIFICATIONS

TUBES	50 x 4 mm (1.97 x 0.16 in)
BRACES	25 x 3 mm (0.98 x 0.12 in)
PLATES	8 mm (0.31 in)
ALLOY	EN AW-6082 T6

LOADING TABLES - COMPLETE TRUSS

		4 m	5 m	6 m	7 m	8 m	10 m	12 m	14 m	16 m	18 m	20 m
UDL [kg/m]		1469	951	655	477	362	226	152	107	78	58	44
Deflection [mm]		10	15	22	30	40	62	90	123	161	205	254
CPL [kg]		2626	2260	1966	1670	1446	1128	910	750	626	526	442
Deflection [mm]		7	12	18	25	32	51	74	102	135	174	218
TPL [kg]		1660	1460	1301	1172	1066	846	683	563	469	394	332
Deflection [mm]		8	13	20	29	39	60	84	110	136	163	188
QPL [kg]		1107	973	867	782	711	564	455	375	313	263	221
Deflection [mm]		7	12	19	27	36	56	78	102	127	152	175
FPL [kg]		876	775	694	628	573	470	379	313	261	219	184
Deflection [mm]		7	12	19	27	37	59	83	108	135	161	186
		13.12 ft	16.40 ft	19.69 ft	22.97 ft	26.25 ft	32.81 ft	39.37 ft	45.93 ft	52.49 ft	59.06 ft	65.62 ft
UDL [lbs/ft]		987.12	639.04	440.14	320.53	243.25	151.87	102.14	71.90	52.41	38.97	29.57
Deflection [in]		0.39	0.59	0.87	1.18	1.57	2.44	3.54	4.84	6.34	8.07	10.00
CPL [lbs]		5789.34	4982.45	4334.29	3681.72	3187.88	2486.81	2006.21	1653.47	1380.09	1159.63	974.44
Deflection [in]		0.28	0.47	0.71	0.98	1.26	2.01	2.91	4.02	5.31	6.85	8.58
TPL [lbs]		3659.67	3218.75	2868.21	2583.82	2350.13	1865.11	1505.76	1241.20	1033.97	868.62	731.93
Deflection [in]		0.31	0.51	0.79	1.14	1.54	2.36	3.31	4.33	5.35	6.42	7.40
QPL [lbs]		2440.52	2145.10	1911.41	1724.01	1567.49	1243.41	1003.10	826.73	690.05	579.82	487.22
Deflection [in]		0.28	0.47	0.75	1.06	1.42	2.20	3.07	4.02	5.00	5.98	6.89
FPL [lbs]		1931.25	1708.58	1530.01	1384.50	1263.25	1036.17	835.55	690.05	575.41	482.81	405.65
Deflection [in]		0.28	0.47	0.75	1.06	1.46	2.32	3.27	4.25	5.31	6.34	7.32

Loading tables are valid for static loads and spans with two supporting points. Spans must be supported at each end. Contact structural engineer if there are more supporting points applied or dynamic and wind loads involved.

SPECS SUMMARY

LOADING TABLES – CENTRAL BOTTOM TUBE

		4 m	5 m	6 m	7 m	8 m	10 m	12 m	14 m	16 m	18 m	20 m
UDL [kg/m]		800	800	655	477	362	226	152	107	78	58	44
Deflection [mm]		5	13	22	30	40	62	90	123	161	205	254
CPL [kg]		800	800	800	800	800	800	800	750	626	526	442
Deflection [mm]		2	4	8	12	19	37	66	102	135	174	218
TPL [kg]		800	800	800	800	800	800	683	563	469	394	332
Deflection [mm]		4	7	12	19	29	57	84	110	136	163	188
QPL [kg]		800	800	800	782	711	564	455	375	313	263	221
Deflection [mm]		5	10	17	27	36	56	78	102	127	152	175
FPL [kg]		800	775	694	628	573	470	379	313	261	219	184
Deflection [mm]		6	12	19	27	37	59	83	108	135	161	186
		13.12 ft	16.40 ft	19.69 ft	22.97 ft	26.25 ft	32.81 ft	39.37 ft	45.93 ft	52.49 ft	59.06 ft	65.62 ft
UDL [lbs/ft]		537.58	537.58	440.14	320.53	243.25	151.87	102.14	71.90	52.41	38.97	29.57
Deflection [in]		0.20	0.51	0.87	1.18	1.57	2.44	3.54	4.84	6.34	8.07	10.00
CPL [lbs]		1763.70	1763.70	1763.70	1763.70	1763.70	1763.70	1763.70	1653.47	1380.09	1159.63	974.44
Deflection [in]		0.08	0.16	0.31	0.47	0.75	1.46	2.60	4.02	5.31	6.85	8.58
TPL [lbs]		1763.70	1763.70	1763.70	1763.70	1763.70	1763.70	1505.76	1241.20	1033.97	868.62	731.93
Deflection [in]		0.16	0.28	0.47	0.75	1.14	2.24	3.31	4.33	5.35	6.42	7.40
QPL [lbs]		1763.70	1763.70	1763.70	1724.01	1567.49	1243.41	1003.10	826.73	690.05	579.82	487.22
Deflection [in]		0.20	0.39	0.67	1.06	1.42	2.20	3.07	4.02	5.00	5.98	6.89
FPL [lbs]		1763.70	1708.58	1530.01	1384.50	1263.25	1036.17	835.55	690.05	575.41	482.81	405.65
Deflection [in]		0.24	0.47	0.75	1.06	1.46	2.32	3.27	4.25	5.31	6.34	7.32

Quicklock Line PT31

SPECIFICATIONS

TUBES	50 x 2 mm (1.97 x 0.08 in)
ALLOY	EN AW-6082 T6

LOADING TABLES

		1 m	2 m	3 m
UDL [kg/m]		287	72	32
Deflection [mm]		6	24	54
CPL [kg]		144	72	47
Deflection [mm]		5	19	44
		3.28 ft	6.56 ft	9.84 ft
UDL [lbs/ft]		192.86	48.38	21.50
Deflection [in]		0.24	0.94	2.13
CPL [lbs]		317.47	158.73	103.62
Deflection [in]		0.20	0.75	1.73

Quicklock Line PT32 double

SPECIFICATIONS

TUBES	50 x 2 mm (1.97 x 0.08 in)
BRACES	16 x 2 mm (0.63 x 0.08 in)
ALLOY	EN AW-6082 T6

LOADING TABLES

		2 m	4 m	6 m	8 m	10 m	12 m
UDL [kg/m]		479	238	107	59	37	25
Deflection [mm]		2	13	29	52	82	118
CPL [kg]		943	487	320	235	183	148
Deflection [mm]		2	10	24	42	67	97
		6.56 ft	13.12 ft	19.69 ft	26.25 ft	32.81 ft	39.37 ft
UDL [lbs/ft]		321.87	159.93	71.90	39.65	24.86	16.80
Deflection [in]		0.08	0.51	1.14	2.05	3.23	4.65
CPL [lbs]		2078.96	1073.65	705.48	518.09	403.45	326.28
Deflection [in]		0.08	0.39	0.94	1.65	2.64	3.82

Loading tables are valid for static loads and spans with two supporting points. Spans must be supported at each end. Contact structural engineer if there are more supporting points applied or dynamic and wind loads involved.

Quicklock Line PT33

SPECIFICATIONS

TUBES	50 x 2 mm (1.97 x 0.08 in)
BRACES	16 x 2 mm (0.63 x 0.08 in)
ALLOY	EN AW-6082 T6

LOADING TABLES		2 m	4 m	6 m	8 m	10 m	12 m
UDL [kg/m]		680	206	97	54	33	20
Deflection [mm]		2.3	11.5	28.1	51	78.3	107.2
CPL [kg]		761	413	292	217	163	133
Deflection [mm]		2.1	9.3	22.7	41.5	64.3	96
		6.56 ft	13.12 ft	19.68 ft	26.24 ft	32.81 ft	39.37 ft
UDL [lbs/ft]		457	138.4	65.2	36.3	22.2	13.4
Deflection [in]		0.1	0.5	1.1	2	3.1	4.2
CPL [lbs]		1678	910.7	643.9	478.5	359.4	293.3
Deflection [in]		0.1	0.4	0.9	1.6	2.5	3.8

Quicklock Line PTH33

SPECIFICATIONS

TUBES	48 x 3 mm (1.89 x 0.12 in)
BRACES	16 x 2 mm (0.63 x 0.08 in)
ALLOY	EN AW-6082 T6

LOADING TABLES		2 m	4 m	6 m	8 m	10 m	12 m
UDL [kg/m]		713	349	152	81	50	30
Deflection [mm]		1.8	13.9	31.4	54.9	86.8	117.2
CPL [kg]		913	552	456	324	249	180
Deflection [mm]		6.1	17.5	25.4	44.8	71.6	98.2
		6.56 ft	13.12 ft	19.69 ft	26.25 ft	32.81 ft	39.37 ft
UDL [lbs/ft]		479.11	234.52	102.14	54.43	33.60	20.16
Deflection [in]		0.07	0.55	1.24	2.16	3.42	4.61
CPL [lbs]		2012.82	1216.95	1005.31	714.30	548.95	396.83
Deflection [in]		0.24	0.69	1.00	1.76	2.82	3.87

Quicklock Line PT34

SPECIFICATIONS

TUBES	50 x 2 mm (1.97 x 0.08 in)
BRACES	16 x 2 mm (0.63 x 0.08 in)
ALLOY	EN AW-6082 T6

LOADING TABLES		2 m	4 m	6 m	8 m	10 m	12 m
UDL [kg/m]		785	390	229	130	81	53
Deflection [mm]		1.4	10.8	32.5	59.3	92.5	130.3
CPL [kg]		1570	961	688	520	406	321
Deflection [mm]		2.2	10.7	26.2	47.9	75.1	106.6
		6.56 ft	13.12 ft	19.68 ft	26.24 ft	32.81 ft	39.37 ft
UDL [lbs/ft]		527.6	262.1	153.9	87.4	54.4	35.6
Deflection [in]		0.1	0.4	1.3	2.3	3.6	5.1
CPL [lbs]		3461.9	2119	1517	1146.6	895.2	707.8
Deflection [in]		0.1	0.4	1	1.9	3	4.2

Quicklock Line PTH34

SPECIFICATIONS

TUBES	48 x 3 mm (1.89 x 0.12 in)
BRACES	16 x 2 mm (0.63 x 0.08 in)
ALLOY	EN AW-6082 T6

LOADING TABLES		2 m	4 m	6 m	8 m	10 m	12 m
UDL [kg/m]		726	359	237	175	124	83
Deflection [mm]		0.9	7.2	24.2	57.5	101.1	144.9
CPL [kg]		1452	1436	1096	802	618	496
Deflection [mm]		1.4	11.4	29.7	52.8	82.2	118.8
		6.56 ft	13.12 ft	19.68 ft	26.24 ft	32.81 ft	39.37 ft
UDL [lbs/ft]		487.8	241.2	159.3	117.6	83.3	55.8
Deflection [in]		0.04	0.3	1.0	2.3	4.0	5.7
CPL [lbs]		3201.1	3165.8	2416.3	1768.1	1362.5	1093.5
Deflection [in]		0.1	0.5	1.2	2.1	3.2	4.7

Loading tables are valid for static loads and spans with two supporting points. Spans must be supported at each end. Contact structural engineer if there are more supporting points applied or dynamic and wind loads involved.

SPECS SUMMARY

Quicklock Line PT44

SPECIFICATIONS

TUBES	50 x 2 mm (1.97 x 0.08 in)
BRACES	20 x 2 mm (0.79 x 0.08 in)
ALLOY	EN AW-6082 T6

LOADING TABLES

		2 m	4 m	6 m	8 m	10 m	12 m
UDL [kg/m]		1045	519	344	204	130	89
Deflection [mm]		0.9	7.2	24.3	46.1	73.1	106.0
CPL [kg]		2090	1670	1090	814	649	531
Deflection [mm]		1.4	9.2	20.6	37.2	59.3	86.4
		6.56 ft	13.12 ft	19.68 ft	26.24 ft	32.81 ft	39.37 ft
UDL [lbs/ft]		702.2	348.8	231.2	137.1	87.4	59.8
Deflection [in]		0.04	0.3	1.0	1.8	2.9	4.2
CPL [lbs]		4607.7	3681.72	2403	1794.6	1430.8	1170.66
Deflection [in]		0.1	0.4	0.8	1.5	2.3	3.4

Quicklock Line PTH44

SPECIFICATIONS

TUBES	48 x 3 mm (1.89 x 0.12 in)
BRACES	20 x 2 mm (0.79 x 0.08 in)
ALLOY	EN AW-6082 T6

LOADING TABLES

		2 m	4 m	6 m	8 m	10 m	12 m
UDL [kg/m]		835	414	274	204	162	126
Deflection [mm]		0.5	4.1	13.8	32.8	64.1	104.6
CPL [kg]		1669	1656	1483	1138	913	755
Deflection [mm]		0.8	6.5	19.8	36.5	58.1	84.8
		6.56 ft	13.12 ft	19.68 ft	26.24 ft	32.81 ft	39.37 ft
UDL [lbs/ft]		561.1	278.2	184.1	137.1	108.9	84.7
Deflection [in]		0.002	0.01	0.05	0.1	0.2	0.3
CPL [lbs]		3679.5	3650.9	3269.5	2508.9	2012.8	1664.5
Deflection [in]		0.03	0.3	0.8	1.4	2.3	3.3

Quicklock Line TS36R

SPECIFICATIONS

TUBES	50 x 4 mm (1.97 x 0.16 in)
BRACES	25 x 3 mm (0.98 x 0.12 in)
ALLOY	EN AW-6082 T6

LOADING TABLES

		4 m	6 m	8 m	10 m	12 m	14 m	16 m	18 m	20 m
UDL [kg/m]		1027	560	320	204	140	101	75	57	45
Deflection [mm]		12	29	51	79	114	155	202	256	317
CPL [kg]		1992	1451	1131	919	767	652	561	486	424
Deflection [mm]		10	21	37	58	85	118	157	202	254
TPL [kg]		1305	987	786	648	547	469	406	355	312
Deflection [mm]		10	24	43	69	102	142	188	242	304
QPL [kg]		1027	801	613	491	405	342	292	252	219
Deflection [mm]		11	26	47	73	105	143	188	240	298
FPL [kg]		861	621	480	387	321	272	233	201	175
Deflection		12	26	46	72	105	145	190	243	302
		13.12 ft	19.69 ft	26.25 ft	32.81 ft	39.37 ft	45.93 ft	52.49 ft	59.06 ft	65.62 ft
UDL [lbs/ft]		690.11	376.30	215.03	137.08	94.08	67.87	50.40	38.30	30.24
Deflection [in]		0.47	1.14	2.01	3.11	4.49	6.10	7.95	10.08	12.48
CPL [lbs]		4391.61	3198.91	2493.43	2026.05	1690.95	1437.41	1236.79	1071.45	934.76
Deflection [in]		0.39	0.83	1.46	2.28	3.35	4.65	6.18	7.95	10.00
TPL [lbs]		2876.64	2175.67	1732.60	1428.40	1205.76	1033.83	894.95	782.53	687.75
Deflection [in]		0.39	0.94	1.69	2.72	4.02	5.59	7.40	9.53	11.97
QPL [lbs]		1898.18	1369.07	1058.22	853.19	707.68	599.66	513.68	443.13	385.81
Deflection [in]		0.43	1.02	1.85	2.87	4.13	5.63	7.40	9.45	11.73
FPL [lbs]		1898.18	1369.07	1058.22	853.19	707.68	599.66	513.68	443.13	385.81
Deflection [in]		0.47	1.02	1.81	2.83	4.13	5.71	7.48	9.57	11.89

Loading tables are valid for static loads and spans with two supporting points. Spans must be supported at each end. Contact structural engineer if there are more supporting points applied or dynamic and wind loads involved.

Quicklock Line TT54M

SPECIFICATIONS

TUBES	50 x 4 mm (1.97 x 0.16 in)
BRACES	30 x 3 mm (1.18 x 0.12 in)
ALLOY	EN AW-6082 T6

LOADING TABLES

		4 m	6 m	8 m	10 m	12 m	14 m	16 m	18 m	20 m	22 m
UDL [kg/m]		1443	957	543	343	234	168	126	96	76	60
Deflection [mm]		5	18	33	51	73	100	131	166	206	250
CPL [kg]		3398	2578	2072	1713	1403	1178	1005	868	755	661
Deflection [mm]		5	13	25	41	60	82	108	138	172	210
TPL [kg]		2141	1689	1391	1180	1023	883	754	651	567	496
Deflection [mm]		5	14	28	47	70	96	122	150	179	209
QPL [kg]		1428	1126	927	787	682	589	503	434	378	331
Deflection [mm]		5	13	26	43	65	89	113	139	166	194
FPL [kg]		1129	900	747	637	554	490	419	362	315	275
Deflection		5	14	27	45	67	94	120	148	177	206
		15.12 ft	19.69 ft	26.25 ft	32.81 ft	39.37 ft	45.93 ft	52.49 ft	59.06 ft	65.62 ft	72.18 ft
UDL [lbs/ft]		969.65	643.07	364.88	230.49	157.24	112.89	84.67	64.51	51.07	40.32
Deflection [in]		0.20	0.71	1.30	2.01	2.87	3.94	5.16	6.54	8.11	9.84
CPL [lbs]		7491.31	5683.52	4567.98	3776.52	3093.09	2597.05	2215.65	1913.61	1664.49	1457.26
Deflection [in]		0.20	0.51	0.98	1.61	2.36	3.23	4.25	5.43	6.77	8.27
TPL [lbs]		4720.10	3723.61	3066.63	2601.45	2255.33	1946.68	1662.29	1435.21	1250.02	1093.49
Deflection [in]		0.20	0.55	1.10	1.85	2.76	3.78	4.80	5.91	7.05	8.23
QPL [lbs]		3148.20	2482.41	2043.69	1735.04	1503.55	1298.52	1108.93	956.81	833.35	729.73
Deflection [in]		0.20	0.51	1.02	1.69	2.56	3.50	4.45	5.47	6.54	7.64
FPL [lbs]		2489.02	1984.16	1646.85	1404.34	1221.36	1080.27	923.74	798.07	694.46	606.27
Deflection [in]		0.20	0.55	1.06	1.77	2.64	3.70	4.72	5.83	6.97	8.11

Loading tables are valid for static loads and spans with two supporting points. Spans must be supported at each end. Contact structural engineer if there are more supporting points applied or dynamic and wind loads involved.

SPECS SUMMARY

Quicklock Line TT74M

SPECIFICATIONS

TUBES	50 x 4 mm (1.97 x 0.16 in)
BRACES	30 x 3 mm (1.18 x 0.12 in)
ALLOY	EN AW-6082 T6

LOADING TABLES

		4 m	6 m	8 m	10 m	12 m	14 m	16 m	18 m	20 m	22 m	24 m	26 m	28 m	30 m	32 m
UDL [kg/m]		1085	718	534	424	351	258	194	150	118	95	77	63	52	44	36
Deflection [mm]		2	6	14	28	48	66	87	110	136	165	197	232	271	312	356
CPL [kg]		3122	2593	2209	1918	1689	1504	1353	1225	1117	1024	927	824	734	654	582
Deflection [mm]		2	6	12	20	32	46	63	83	107	135	165	196	230	268	308
TPL [kg]		1785	1541	1351	1199	1075	972	885	810	745	688	638	594	551	490	436
Deflection [mm]		2	6	12	21	32	46	63	82	103	127	153	181	210	230	248
QPL [kg]		1190	1027	901	800	717	648	590	540	497	459	426	396	367	327	291
Deflection [mm]		2	5	11	19	30	43	58	76	96	118	142	168	195	214	231
FPL [kg]		919	800	707	631	569	516	471	433	399	370	343	320	299	272	242
Deflection		2	5	11	19	30	44	60	78	98	121	146	173	202	227	245
		13.12 ft	19.69 ft	26.25 ft	32.81 ft	39.37 ft	45.93 ft	52.49 ft	59.06 ft	65.62 ft	72.18 ft	78.74 ft	85.3 ft	91.86 ft	98.43 ft	104.99 ft
UDL [lbs/ft]		729.09	482.47	358.83	284.92	235.86	173.37	130.36	100.80	79.29	63.84	51.74	42.33	34.94	29.57	24.19
Deflection [in]		0.08	0.24	0.55	1.10	1.89	2.60	3.43	4.33	5.35	6.50	7.76	9.13	10.67	12.28	14.02
CPL [lbs]		6882.83	5716.59	4870.01	4228.47	3723.61	3315.75	2982.85	2700.66	2462.56	2257.53	2043.69	1816.61	1618.19	1441.82	1283.09
Deflection [in]		0.08	0.24	0.47	0.79	1.26	1.81	2.48	3.27	4.21	5.31	6.50	7.72	9.06	10.55	12.13
TPL [lbs]		3935.25	3397.32	2978.45	2643.34	2369.97	2142.89	1951.09	1785.74	1642.44	1516.78	1406.55	1309.55	1214.75	1080.27	961.22
Deflection [in]		0.08	0.24	0.47	0.83	1.26	1.81	2.48	3.23	4.06	5.00	6.02	7.13	8.27	9.06	9.76
QPL [lbs]		2623.50	2264.15	1986.36	1763.70	1580.71	1428.60	1300.73	1190.50	1095.70	1011.92	939.17	873.03	809.10	720.91	641.55
Deflection [in]		0.08	0.20	0.43	0.75	1.18	1.69	2.28	2.99	3.78	4.65	5.59	6.61	7.68	8.43	9.09
FPL [lbs]		2026.05	1763.70	1558.67	1391.12	1254.43	1137.59	1038.38	954.60	879.64	815.71	756.19	705.48	659.18	599.66	533.52
Deflection [in]		0.08	0.20	0.43	0.75	1.18	1.73	2.36	3.07	3.86	4.76	5.75	6.81	7.95	8.94	9.65

Loading tables are valid for static loads and spans with two supporting points. Spans must be supported at each end. Contact structural engineer if there are more supporting points applied or dynamic and wind loads involved.

Quicklock Line TT104M

SPECIFICATIONS

TUBES	60 x 6 mm (2.36 x 0.24 in)
BRACES	30 x 3 mm (1.18 x 0.12 in)
ALLOY	EN AW-6082 T6

LOADING TABLES

		8 m	10 m	12 m	14 m	16 m	18 m	20 m	22 m	24 m
UDL [kg/m]		1441.6	1148.7	835.7	607.9	460	358.7	286.2	232.5	191.7
Deflection [mm]		11.9	23.3	35.4	48.3	63.1	80	98.9	119.9	142.9
CPL [kg]		5880*	5157*	4513*	4000*	3570*	3196*	2861.7	2557.8	2300.7
Deflection [mm]		9.8	16.9	25.8	36.8	49.7	64.4	80.7	98.3	117.7
TPL [kg]		3608	3276	2933	2681	2429	2227	2039	1880	1725.5
Deflection [mm]		10.2	18.2	28.4	41.7	57.1	75.5	96.3	120.1	145.7
QPL [kg]		2673	2457	2256	2085	1840.2	1614	1430.9	1278.9	1150.3
Deflection [mm]		10.5	19	30.4	45.1	60.1	76.2	94.3	114.5	136.6
FPL [kg]		2134	1997	1859	1738	1533.5	1345	1192.4	1065.7	958.6
Deflection		10.7	19.7	31.9	47.7	63.6	80.6	99.6	120.7	143.9
		26.25 ft	32.81 ft	39.37 ft	45.93 ft	52.49 ft	59.06 ft	65.62 ft	72.18 ft	78.74 ft
UDL [lbs/ft]		968.71	771.89	561.56	408.49	309.11	241.04	192.32	156.23	128.82
Deflection [in]		0.47	0.92	1.39	1.90	2.48	3.15	3.89	4.72	5.63
CPL [lbs]		12963.18	11369.24	9949.46	8818.49	7870.50	7045.97	6308.97	5638.98	5072.18
Deflection [in]		0.39	0.67	1.02	1.45	1.96	2.54	3.18	3.87	4.63
TPL [lbs]		7954.28	7222.34	6466.16	5910.59	5355.03	4909.69	4495.23	4144.69	3804.08
Deflection [in]		0.40	0.72	1.12	1.64	2.25	2.97	3.79	4.73	5.74
QPL [lbs]		5892.96	5416.76	4973.63	4596.64	4056.95	3558.26	3154.59	2819.49	2535.98
Deflection [in]		0.41	0.75	1.20	1.78	2.37	3.00	3.71	4.51	5.38
FPL [lbs]		4704.66	4402.63	4098.39	3831.63	3380.79	2965.22	2628.79	2349.47	2113.35
Deflection [in]		0.42	0.78	1.26	1.88	2.50	3.17	3.92	4.75	5.67

LOADING TABLES

		26 m	28 m	30 m	32 m	34 m	36 m	38 m	40 m	42 m
UDL [kg/m]		160	134.8	114.4	97.8	84	72.5	62.7	54.3	47.2
Deflection [mm]		168.1	195.3	224.8	256.4	290.2	326.3	364.6	405.3	448.3
CPL [kg]		2079.6	1886.8	1716.7	1564.9	1428.4	1304.4	1191.1	1086.8	990.3
Deflection [mm]		139.1	162.5	188	215.7	245.7	278	312.8	350.1	390.1
TPL [kg]		1559.7	1415.1	1287.5	1173.7	1071.3	978.3	893.3	815.1	742.7
Deflection [mm]		171.3	199	228.9	260.9	295.2	331.6	370.4	411.4	454.7
QPL [kg]		1039	943.4	858.3	782.5	714.2	652.2	595.5	543.4	495.1
Deflection [mm]		160.8	187.1	215.6	246.2	279.1	314.2	351.6	391.5	433.7
FPL [kg]		866.5	786.2	715.3	652.1	595.2	543.5	496.3	452.8	412.6
Deflection		169.2	196.7	226.2	258	292	328.2	366.7	407.5	450.6
		85.3 ft	91.86 ft	98.43 ft	104.99 ft	111.55 ft	118.11 ft	124.67 ft	131.23 ft	137.80 ft
UDL [lbs/ft]		107.52	90.58	76.87	65.72	56.45	48.72	42.13	36.49	31.72
Deflection [in]		6.62	7.69	8.85	10.09	11.43	12.85	14.35	15.96	17.65
CPL [lbs]		4584.73	4159.68	3784.68	3450.01	3149.08	2875.71	2625.93	2395.98	2183.24
Deflection [in]		5.48	6.40	7.40	8.49	9.67	10.94	12.31	13.78	15.36
TPL [lbs]		3438.55	3119.76	2838.45	2587.57	2361.81	2156.78	1969.39	1796.99	1637.37
Deflection [in]		6.74	7.83	9.01	10.27	11.62	13.06	14.58	16.20	17.90
QPL [lbs]		2290.60	2079.84	1892.23	1725.12	1574.54	1437.85	1312.85	1197.99	1091.51
Deflection [in]		6.33	7.37	8.49	9.69	10.99	12.37	13.84	15.41	17.07
FPL [lbs]		1910.31	1733.27	1576.97	1437.63	1312.19	1198.21	1094.15	998.25	909.63
Deflection [in]		6.66	7.74	8.91	10.16	11.50	12.92	14.44	16.04	17.74

Loading tables are valid for static loads and spans with two supporting points. Spans must be supported at each end. Contact structural engineer if there are more supporting points applied or dynamic and wind loads involved. High values of distributed loads are idealized. Loads must be applied to knot points! * limited by interaction of shear and movement at the connection Displacement connection is decisive!

SPECS SUMMARY

Bolted Truss FTB-L

SPECIFICATIONS

TUBES	50 x 3 mm (1.97 x 0.12 in)
BRACES	25 x 3 mm (0.98 x 0.12 in)
ALLOY	EN AW-6082 T6

LOADING TABLES

		1.52 m	3.05 m	4.57 m	6.1 m	7.6 m	9.14 m	12.2 m
UDL [kg/m]		1512	605	342	187	116	77	38
Deflection [mm]		0.6	3.6	10.6	18.9	29.6	42.8	77
CPL [kg]		1149	922	782	571	442	353	234
Deflection [mm]		0.5	3.3	9.7	17.3	27.2	39.3	71.1
		5 ft	10 ft	15 ft	20 ft	25 ft	30 ft	40 ft
UDL [lbs/ft]		1016	407	230	126	78	52	26
Deflection [in]		0.02	0.1	0.4	0.7	1.2	1.7	3
CPL [lbs]		2534	2033	1724	1259	975	778	516
Deflection [in]		0.02	0.1	0.4	0.7	1.1	1.5	2.8

Bolted Truss FTB-M

SPECIFICATIONS

TUBES	50 x 3 mm (1.97 x 0.12 in)
BRACES	25 x 3 mm (0.98 x 0.12 in)
ALLOY	EN AW-6082 T6

LOADING TABLES

		1.52 m	3.05 m	4.57 m	6.1 m	7.6 m	9.14 m	12.2 m
UDL [kg/m]		2324	1150	694	382	239	162	84
Deflection [mm]		0.2	2	6.2	11.1	17.3	24.9	44.8
CPL [kg]		2879	2251	1585	1166	912	739	512
Deflection [mm]		0.4	2.4	5.7	10.1	15.9	22.9	41.2
		5 ft	10 ft	15 ft	20 ft	25 ft	30 ft	40 ft
UDL [lbs/ft]		1562	773	466	257	161	109	57
Deflection [in]		0.01	0.1	0.2	0.4	0.7	1	1.8
CPL [lbs]		6348	4964	3495	2571	2011	1630	1129
Deflection [in]		0.02	0.1	0.2	0.4	0.6	0.9	1.6

Bolted Truss FTB-H

SPECIFICATIONS

TUBES	50 x 3 mm (1.97 x 0.12 in)
BRACES	25 x 3 mm (0.98 x 0.12 in)
ALLOY	EN AW-6082 T6

LOADING TABLES

		1.52 m	3.05 m	4.57 m	6.1 m	7.6 m	9.14 m	12.2 m
UDL [kg/m]		1982	980	649	482	382	272	145
Deflection [mm]		0.1	0.8	2.5	6	11.8	17.6	31.5
CPL [kg]		3013	2989	2594	1922	1516	1241	887
Deflection [mm]		0.2	1.4	4	7.2	11.2	16.2	29
		5 ft	10 ft	15 ft	20 ft	25 ft	30 ft	40 ft
UDL [lbs/ft]		1332	659	436	324	257	183	97
Deflection [in]		0.01	0.03	0.1	0.2	0.5	0.7	1.2
CPL [lbs]		6644	6591	5720	4238	3343	2736	1956
Deflection [in]		0.01	0.1	0.2	0.3	0.4	0.6	1.1

Loading tables are valid for static loads and spans with two supporting points. Spans must be supported at each end. Contact structural engineer if there are more supporting points applied or dynamic and wind loads involved.

Fork Truss **GS350**

SPECIFICATIONS

TUBES	48 x 4.5 mm (1.89 x 0.18 in)
BRACES	25 x 3 mm (0.98 x 0.12 in)
ALLOY	EN AW-6082 T6

LOADING TABLES

		3 m	4 m	6 m	8 m	10 m	12 m	13 m	14 m	15 m	16 m	17 m
UDL [kg/m]		1578	1180	557	308	195	133	111	94	80	69	60
Deflection [mm]		4.4	10.3	25	44.4	70.2	101.8	119.7	139	159.4	180.8	205.2
CPL [kg]		3276	2539	1672	1231	974	795	724	661	604	552	510
Deflection [mm]		4.8	8.9	20.1	35.9	57	83.2	98.2	114.5	131.8	150.2	171.3
TPL [kg]		2366	1904	1254	924	730	596	543	495	453	414	383
Deflection [mm]		5.9	11.3	25.5	45.4	71.6	103.9	122.1	141.7	162.5	184.2	209
QPL [kg]		1578	1269	836	616	487	398	362	330	302	276	255
Deflection [mm]		5.5	10.6	23.8	42.3	66.9	97.2	144.4	132.9	152.5	173.2	196.7
FPL [kg]		1183	1058	697	513	406	331	302	275	252	230	213
Deflection		5.3	11.3	25.4	45.1	71.3	103.4	121.6	141.1	161.8	183.5	208.1
		9.84 ft	13.12 ft	19.68 ft	26.24 ft	32.8 ft	39.36 ft	42.64 ft	45.92 ft	49.2 ft	52.48 ft	55.76 ft
UDL [lbs/ft]		1060.37	792.92	374.29	206.97	131.03	89.37	74.59	63.17	53.76	46.37	40.32
Deflection [in]		0.17	0.41	0.98	1.75	2.76	4.01	4.71	5.47	6.28	7.12	8.08
CPL [lbs]		7222.34	5597.54	3686.13	2713.89	2147.30	1752.67	1596.15	1457.26	1331.59	1216.95	1124.36
Deflection [in]		0.19	0.35	0.79	1.41	2.24	3.28	3.87	4.51	5.19	5.91	6.74
TPL [lbs]		5216.14	4197.60	2764.60	2037.07	1609.37	1313.96	1197.11	1091.29	998.69	912.71	844.37
Deflection [in]		0.23	0.44	1.00	1.79	2.82	4.09	4.81	5.58	6.40	7.25	8.23
QPL [lbs]		3478.89	2797.67	1843.06	1358.05	1073.65	877.44	798.07	727.53	665.80	608.48	562.18
Deflection [in]		0.22	0.42	0.94	1.67	2.63	3.83	5.69	5.23	6.00	6.82	7.74
FPL [lbs]		2608.07	2332.49	1536.62	1130.97	895.08	729.73	665.80	606.27	555.56	507.06	469.58
Deflection [in]		0.21	0.44	1.00	1.78	2.81	4.07	4.79	5.56	6.37	7.22	8.19

Loading tables are valid for static loads and spans with two supporting points. Spans must be supported at each end. Contact structural engineer if there are more supporting points applied or dynamic and wind loads involved.







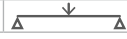

SPECS SUMMARY

Fork Truss GS500N

SPECIFICATIONS

TUBES	48 x 4.5 mm (1.89 x 0.18 in)
BRACES	30 x 3 mm (1.18 x 0.12 in)
ALLOY	EN AW-6082 T6

LOADING TABLES







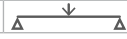

	4 m	6 m	8 m	10 m	12 m	14 m	16 m	18 m	20 m	22 m	24 m
UDL [kg/m] 	1467	670	369	230	154	108	79	58	44	33	25
Deflection [mm]	6	13	23	36	52	71	94	119	148	180	216
CPL [kg] 	2657	1954	1476	1148	924	758	630	526	439	365	300
Deflection [mm]	4	10	19	30	43	59	79	102	128	158	192
TPL [kg] 	1731	1318	1060	861	693	569	472	394	329	274	225
Deflection [mm]	4	11	22	35	48	63	78	93	106	117	125
QPL [kg] 	1154	878	707	574	462	379	315	263	220	182	150
Deflection [mm]	4	11	20	32	45	58	72	86	99	109	116
FPL [kg] 	921	708	573	478	385	316	262	219	183	152	125
Deflection	4	11	21	34	48	62	77	91	105	116	123
	13.12 ft	19.69 ft	26.25 ft	32.81 ft	39.37 ft	45.93 ft	52.49 ft	59.06 ft	65.62 ft	72.18 ft	78.74 ft
UDL [lbs/ft] 	985.78	450.22	247.96	154.55	103.48	72.57	53.09	38.97	29.57	22.17	16.80
Deflection [in]	0.24	0.51	0.91	1.42	2.05	2.80	3.70	4.69	5.83	7.09	8.50
CPL [lbs] 	5857.68	4307.83	3254.02	2530.91	2037.07	1671.10	1388.91	1159.63	967.83	804.69	661.39
Deflection [in]	0.16	0.39	0.75	1.18	1.69	2.32	3.11	4.02	5.04	6.22	7.56
TPL [lbs] 	3816.20	2905.69	2336.90	1898.18	1527.80	1254.43	1040.58	868.62	725.32	604.07	496.04
Deflection [in]	0.16	0.43	0.87	1.38	1.89	2.48	3.07	3.66	4.17	4.61	4.92
QPL [lbs] 	2544.13	1935.66	1558.67	1265.45	1018.54	835.55	694.46	579.82	485.02	401.24	330.69
Deflection [in]	0.16	0.43	0.79	1.26	1.77	2.28	2.83	3.39	3.90	4.29	4.57
FPL [lbs] 	2030.46	1560.87	1263.25	1053.81	848.78	696.66	577.61	482.81	403.45	335.10	275.58
Deflection [in]	0.16	0.43	0.83	1.34	1.89	2.44	3.03	3.58	4.13	4.57	4.84

Fork Truss GS620

SPECIFICATIONS

TUBES	48 x 4.5 mm (1.89 x 0.18 in)
BRACES	30 x 3 mm (1.18 x 0.12 in)
ALLOY	EN AW-6082 T6

LOADING TABLES

	4 m	6 m	8 m	10 m	12 m	14 m	16 m	17 m	18 m	19 m	20 m
UDL [kg/m] 	1657	1076	603	383	264	190	142	124	109	97	86
Deflection [mm]	4	13.2	23.7	37.3	54.1	73.9	96.7	109.3	122.7	136.9	151.9
CPL [kg] 	4702	3227	2412	1916	1583	1331	1138	1058	985	920	860
Deflection [mm]	4.5	10.6	19.1	30.1	43.9	60.2	79.3	89.9	101.2	113.3	126.2
TPL [kg] 	3315	2421	1809	1437	1188	998	854	793	739	690	645
Deflection [mm]	5.4	13.5	24.2	38.1	55.3	75.4	98.6	111.4	125.1	139.5	154.8
QPL [kg] 	2210	1614	12.6	958	792	666	569	529	493	460	430
Deflection [mm]	5.1	12.6	22.5	35.5	51.6	70.4	92.3	104.4	117.3	131	145.5
FPL [kg] 	1657	1345	1005	799	660	555	474	441	411	383	358
Deflection	4.9	13.4	24.1	37.9	55	75	98.2	111	124.5	138.9	134.1
	13.12 ft	19.68 ft	26.24 ft	32.8 ft	39.36 ft	45.92 ft	52.48 ft	55.76 ft	59.04 ft	62.32 ft	65.6 ft
UDL [lbs/ft] 	1113.45	723.04	405.20	257.36	177.40	127.67	95.42	83.32	73.24	65.18	57.79
Deflection [in]	0.16	0.52	0.93	1.47	2.13	2.91	3.81	4.30	4.83	5.39	5.98
CPL [lbs] 	10366.14	7114.32	5317.55	4224.06	3489.92	2934.35	2508.86	2332.49	2171.55	2028.25	1895.98
Deflection [in]	0.18	0.42	0.75	1.19	1.73	2.37	3.12	3.54	3.98	4.46	4.97
TPL [lbs] 	7308.32	5337.39	3988.16	3168.04	2619.09	2200.21	1882.75	1748.27	1629.22	1521.19	1421.98
Deflection [in]	0.21	0.53	0.95	1.50	2.18	2.97	3.88	4.39	4.93	5.49	6.09
QPL [lbs] 	4872.22	3558.26	27.78	2112.03	1746.06	1468.28	1254.43	1166.25	1086.88	1014.13	947.99
Deflection [in]	0.20	0.50	0.89	1.40	2.03	2.77	3.63	4.11	4.62	5.16	5.73
FPL [lbs] 	3653.06	2965.22	2215.65	1761.49	1455.05	1223.57	1044.99	972.24	906.10	844.37	789.25
Deflection [in]	0.19	0.53	0.95	1.49	2.17	2.95	3.87	4.37	4.90	5.47	5.28

Fork Truss **GS910**

SPECIFICATIONS

TUBES	60 x 5 mm (2.36 x 0.18 in)
BRACES	40 x 3 mm (1.57 x 0.12 in)
ALLOY	EN AW-6082 T6

LOADING TABLES

		4 m	6 m	8 m	10 m	12 m	14 m	16 m	17 m	18 m	19 m	20 m
UDL [kg/m]		1870	1241	927	738	603	439	332	292	259	230	206
Deflection [mm]		1.4	4.8	11.4	22.3	38.1	51.9	67.8	76.6	86	95.8	106.3
CPL [kg]		7514	7388	5511	4378	3618	3070	2654	2482	2327	2188	2062
Deflection [mm]		2.3	7.6	13.6	21.2	30.7	41.9	55	62.2	69.9	78.1	86.8
TPL [kg]		3740	3723	3706	3284	2713	2302	1991	1861	1745	1641	1547
Deflection [mm]		1.9	6.5	15.5	27	38.9	53	69.2	78.2	87.7	97.8	108.5
QPL [kg]		2493	2482	2471	2189	1809	1535	1327	1241	1164	1094	1031
Deflection [mm]		1.8	6.1	14.4	25.1	36.2	49.4	64.6	73	82	91.4	101.4
FPL [kg]		1870	1862	1853	1824	1507	1279	1106	1034	970	912	859
Deflection		1.7	5.9	13.9	26.9	38.7	52.7	68.9	77.9	87.3	97.4	108
		13.12 ft	19.68 ft	26.24 ft	32.8 ft	39.36 ft	45.92 ft	52.48 ft	55.76 ft	59.04 ft	62.32 ft	65.6 ft
UDL [lbs/ft]		1256.58	833.91	622.92	495.91	405.20	294.99	223.09	196.22	174.04	154.55	138.43
Deflection [in]		0.06	0.19	0.45	0.88	1.50	2.04	2.67	3.02	3.39	3.77	4.19
CPL [lbs]		16665.53	16287.75	12149.68	9651.84	7976.32	6768.19	5851.07	5471.87	5130.16	4823.71	4545.93
Deflection [in]		0.09	0.30	0.54	0.83	1.21	1.65	2.17	2.45	2.75	3.07	3.42
TPL [lbs]		8245.29	8207.81	8170.33	7239.98	5981.14	5075.04	4389.40	4102.80	3847.07	3617.79	3410.55
Deflection [in]		0.07	0.26	0.61	1.06	1.53	2.09	2.72	3.08	3.45	3.85	4.27
QPL [lbs]		5496.12	5471.87	5447.62	4825.92	3988.16	3384.10	2925.53	2735.94	2566.18	2411.86	2272.97
Deflection [in]		0.07	0.24	0.57	0.99	1.43	1.94	2.54	2.87	3.23	3.60	3.99
FPL [lbs]		4122.64	4105.01	4085.17	4021.23	3322.37	2819.71	2438.31	2279.58	2138.48	2010.62	1893.77
Deflection [in]		0.07	0.23	0.55	1.06	1.52	2.07	2.71	3.07	3.44	3.83	4.25

Fork Truss **PR1**

SPECIFICATIONS

TUBES	48 x 4.5 mm (1.89 x 0.18 in)
BRACES	25 x 3 mm (0.98 x 0.12 in)
ALLOY	EN AW-6082 T6

LOADING TABLES LC1 - LOADING OF THE TRUSS

		6 m	8 m	10 m	12 m	14 m	16 m	18 m	20 m
UDL [kg/m]		589	325	204	137	97	72	54	41
Deflection [mm]		24.9	44.4	69.5	100.4	137.2	179.9	228.7	283.7
CPL [kg]		1766	1302	1018	824	682	573	484	411
Deflection [mm]		20.1	35.9	56.6	82.3	113.3	150.0	192.6	241.8
		19.69 ft	26.25 ft	32.81 ft	39.37 ft	45.93 ft	52.49 ft	59.06 ft	65.62 ft
UDL [lbs/ft]		395.79	218.39	137.08	92.06	65.18	48.38	36.29	27.55
Deflection [in]		0.08	0.15	0.23	0.33	0.45	0.59	0.75	0.93
CPL [lbs]		3893.4	2870.4	2244.3	1816.6	1503.6	1263.2	1067.0	906.1
Deflection [in]		0.8	1.4	2.2	3.2	4.5	5.9	7.6	9.5

LOADING TABLES LC2 - LOADING AT CENTER TUBE

		6 m	8 m	10 m	12 m	14 m	16 m	18 m	20 m
UDL [kg/m]		450	325	203	137	97	72	54	41
Deflection [mm]		19.2	44.4	69.5	100.4	137.1	179.8	228.5	283.5
CPL [kg]		420	420	420	420	420	420	420	411
Deflection [mm]		5.2	12.9	26.0	46.6	76.5	118.0	173.5	241.6
		19.69 ft	26.25 ft	32.81 ft	39.37 ft	45.93 ft	52.49 ft	59.06 ft	65.62 ft
UDL [lbs/ft]		302.39	218.39	136.41	92.06	65.18	48.38	36.29	27.55
Deflection [in]		0.76	1.75	2.74	3.95	5.40	7.08	9.00	11.16
CPL [lbs]		925.94	925.94	925.94	925.94	925.94	925.94	925.94	906.10
Deflection [in]		0.20	0.51	1.02	1.83	3.01	4.65	6.83	9.51

Loading tables are valid for static loads and spans with two supporting points. Spans must be supported at each end. Contact structural engineer if there are more supporting points applied or dynamic and wind loads involved.

SPECS SUMMARY

Fork Truss PR2

SPECIFICATIONS

TUBES	50 x 4 mm (1.97 x 0.16 in)
BRACES	25 x 3 mm (0.98 x 0.12 in)
ALLOY	EN AW-6082 T6

LOADING TABLES LC1 - LOADING OF THE TRUSS

		6 m	8 m	10 m	12 m	14 m	16 m	18 m	20 m
UDL [kg/m]		568	319	206	139	99	71	53	39
Deflection [mm]		27.2	49.2	79.1	114.3	155.9	201.1	253.1	305.2
CPL [kg]		1704	1278	1028	834	690	569	475	388
Deflection [mm]		21.9	39.8	64.3	93.6	128.6	167.6	213.2	260.5
		19.69 ft	26.25 ft	32.81 ft	39.37 ft	45.93 ft	52.49 ft	59.06 ft	65.62 ft
UDL [lbs/ft]		381.68	214.36	138.43	93.40	66.52	47.71	35.61	26.21
Deflection [in]		0.09	0.16	0.26	0.38	0.51	0.66	0.83	1.00
CPL [lbs]		3756.68	2817.51	2266.35	1838.66	1521.19	1254.43	1047.20	855.40
Deflection [in]		0.86	1.57	2.53	3.69	5.06	6.60	8.39	10.26

LOADING TABLES LC2 - LOADING AT CENTER TUBE

		6 m	8 m	10 m	12 m	14 m	16 m	18 m	20 m
UDL [kg/m]		568	319	206	139	99	71	53	39
Deflection [mm]		27.2	49.2	79.1	114.3	155.9	201.1	253.1	305.2
CPL [kg]		520	520	520	520	520	520	475	388
Deflection [mm]		7.1	17.4	35.0	62.3	101.8	156.1	213.2	260.5
		19.69 ft	26.25 ft	32.81 ft	39.37 ft	45.93 ft	52.49 ft	59.06 ft	65.62 ft
UDL [lbs/ft]		381.68	214.36	138.43	93.40	0.51	47.71	35.61	26.21
Deflection [in]		0.09	0.16	0.26	0.38	5.40	0.66	0.83	1.00
CPL [lbs]		1146.40	1146.40	1146.40	1146.40	1146.40	1146.40	1047.20	855.39
Deflection [in]		0.28	0.69	1.38	2.45	4.01	6.15	8.39	10.26

Loading tables are valid for static loads and spans with two supporting points. Spans must be supported at each end. Contact structural engineer if there are more supporting points applied or dynamic and wind loads involved.



Truss Aluminium Factory

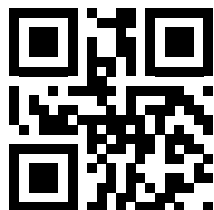



TAF CZECH REPUBLIC

Truss Aluminium Factory a.s.
Hodolany 1226
779 00 Olomouc
Czech Republic
Tel.: +420 730 893 969
E-mail: sales@taf.cz

TAF-UK LTD

8 Fryers Road
Walsall, West Midlands
WS2 7LZ
United Kingdom
Tel: +44 192 2495 396
E-mail: sales@taf-uk.com

TAF USA, LLC

1585 Industrial Dr.
New Smyrna Beach
FL 32168
United States
Call toll free within the U.S.: (877)556-1999
Outside of the U.S.: 1-386-756-1999
E-mail: sales@taf-usa.com

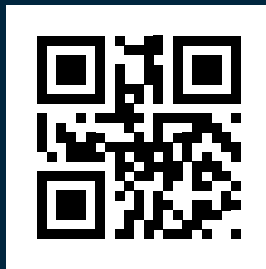

www.taf.cz